



KENYA RURAL ROADS AUTHORITY

**(TURKANA REGION)
TURKANA EAST CONSTITUENCY**

10%RMLF FUNDING FY 2018-2019

ROUTINE IMPROVEMENT

ROAD NAME: NAPAKAELIM –LOKORI

TENDER NUMBER: KeRRA/011/TUR/39/537/2018-2019

RESERVATIONS: OPEN

MARCH 2019

The Engineer:

**REGIONAL MANAGER,
KENYA RURAL ROADS AUTHORITY,
P.O. BOX 113-30500,
TURKANA.**

The Employer:

**DIRECTOR GENERAL,
KENYA RURAL ROADS AUTHORITY,
P.O. BOX 48151-00100,
NAIROBI.**

STANDARD TENDER DOCUMENT

FOR

(NAPAKAELIM –LOKORI)

PROCUREMENT OF WORKS

(SPOT IMPROVEMENT WORKS)

Table of Contents

TABLE OF CONTENTS	ERROR! BOOKMARK NOT DEFINED.
SECTION 1: INVITATION FOR TENDERS.....	3
SECTION 2: FORM OF BID.....	4
SECTION 3: APPENDIX TO FORM OF BID	6
SECTION 4: FORM OF BID SECURITY	8
SECTION 6: QUALIFICATION CRITERIA	17
SECTION 7: CONDITIONS OF CONTRACT	22
SECTION 8: APPENDIX TO FORM OF AGREEMENT	33
SECTION 9: STANDARD FORMS	35
SECTION 10: FORM OF AGREEMENT	49
SECTION 11: FORMS OF PERFORMANCE BANK GUARANTEE AND ADVANCE PAYMENT GUARANTEE (UNCONDITIONAL)	52
SECTION 12: OTHER SUPPLEMENTARY REQUIREMENTS.....	57
12.1 ADJUDICATOR’S AGREEMENT	57
12.2 FRAUD & CORRUPTION:	59
12.3 ENVIRONMENTAL AND SOCIAL COMMITMENT:	60
12.4 DECLARATION FORM:	61
SECTION 14: SPECIFICATIONS, DRAWINGS AND BILLS OF QUANTITIES	63

SECTION 1: INVITATION FOR TENDERS

Tender Reference No: KeRRA/011/TUR/39/537/2018/2019

Tender Name: Spot improvement of Napakaelim –Lokori

- 1.1 The Kenya Rural Roads Authority (Turkana Region) invites sealed tenders for the construction of **Spot improvement of Napakaelim –Lokori.**
- 1.2 Interested eligible candidates may obtain further information and inspect tender documents (and additional information) at the Procurement office during normal working hours.
- 1.3 A complete set of tender documents may be obtained by interested candidates by downloading from the KeRRA website: www.kerra.go.ke free of charge.
- 1.4 Prices quoted should be net inclusive of all government taxes, must be in Kenya shillings and shall remain valid for **120** days from the closing date of tender.
- 1.5 Completed tender documents are to be enclosed in plain sealed envelopes marked with Tender name and reference number and deposited in the **Tender Box at Regional Office (KeRRA Turkana) or to be addressed to Regional Manager, KeRRA Turkana Region, P.O Box 113-30500 Turkana, so as to be received on or before (16th April, 2019).**
- 1.6 Tenders will be opened immediately thereafter in the presence of the Candidates or their representatives who choose to attend.

For (Accounting Officer/Procuring Entity)

SECTION 2: FORM OF BID

FORM OF TENDER

NAME OF CONTRACT: **IMPROVEMENT OF:**.....

CONTRACT No......

TO: The Regional Manager – Turkana Region,
Kenya Rural Roads Authority,
P.O.BOX 113– 30500,
TURKANA, Kenya.

Dear Sir,

1. In accordance with the Conditions of Contract, Specifications, Drawings and Bills of Quantities for the execution of the above Works, We, the undersigned offer to construct, install and complete such Works and remedy any defects therein for the sum of Kshs. _____ [Amount in figures]
Kenya Shillings _____
_____ [Amount in words]
2. We undertake, if our Tender is accepted, to commence the Works on the commencement date and to complete the whole of the Works comprised in the Contract within the time stated in the Appendix.
3. We agree to abide by this Tender until _____ [Insert date], and it shall remain binding upon us and may be accepted at any time before that date.
4. Unless and until a formal Agreement is prepared and executed this Tender together with your written acceptance thereof, shall constitute a binding Contract between us.
4. We understand that you are not bound to accept the lowest or any Tender you may receive.

Dated this _____ day of _____ 20 _____

Signature _____ in the capacity of _____

duly authorized to sign Tenders for and on behalf of _____ [Name of Tenderer] of

_____ [Address of Tenderer]

Witness: Name _____

Address _____

Signature _____

Date _____

SECTION 3: APPENDIX TO FORM OF BID

**APPENDIX TO FORM OF BID:
(This appendix forms part of the bid)**

CONDITIONS OF CONTRACT	CLAUSE	AMOUNT
Bid Security (Bank Guarantee/Insurance Guarantee)		NA
Amount of Performance Security (Unconditional Bank Guarantee)	10.1	NA
Program to be submitted	14.1	NA
Cash flow estimate to be submitted	14.3	NA
Third-Party Insurance	23.2	Should be submitted 7 days before issuance of order to commence
Period for commencement, from Engineer's Order to commence.	41.1	7 days
Time for completion.	43.1	Below Kshs 6million - 120 days (4 Months)
Amount of liquidated damages.	47.2	0.001% of contract value per day
Limit of liquidated damages	47.2	10% of Contract Value
Defects Liability period		N/A
Percentage of Retention	60.3	NA
Limit of Retention Money	60.3	5% of Contract Price
Minimum amount of interim certificates	60.2	NA
Time within which payment to be made after Interim Payment Certificate signed by Engineer	60.10	NA
Time within which payment to be made after Final Payment Certificate signed by Engineer	60.10	30 days
Amount of Advance	60.12	NA
Advance Payment Security	60.12	NA
Appointer of Arbitrator/Adjudicator	67.3	The Chartered Institute of Arbitrators (Kenya)
Notice to Employer and Engineer	68.2	The Director General, Kenya Rural Roads Authority, P.O.BOX 48151 – 00100, <u>NAIROBI, KENYA</u> The Engineer's address is: Regional Manager (Turkana) Kenya Rural Roads Authority P.O.BOX 113 - 30500 <u>TURKANA, LODWAR.</u>

Signature of Bidder

Date

SECTION 4: FORM OF BID SECURITY

2. TENDER-SECURING DECLARATION FORM (Reserved Groups)

[The Bidder shall complete this Form in accordance with the instructions indicated]

Date: [.....of Bid Submission]

Tender No.: [.....]

To: The Regional Manager,
Kenya Rural Roads Authority,
P. O. Box **113-30500**,
Turkana-Lodwar.

I/We, the undersigned, declare that:

1. I/We understand that, according to your conditions, bids must be supported by a Bid-Securing Declaration.
2. I/We accept that I/we will automatically be suspended from being eligible for bidding in any contract with the Purchaser for the period of time of [insert number of months or years] starting on [insert date], if we are in breach of our obligation(s) under the bid conditions, because we – (a) have withdrawn our Bid during the period of bid validity specified by us in the Bidding Data Sheet; or (b) having been notified of the acceptance of our Bid by the Purchaser during the period of bid validity, (i) fail or refuse to execute the Contract, if required, or (ii) fail or refuse to furnish the Performance Security, in accordance with the instructions to tenders.
3. I/We understand that this Bid Securing Declaration shall expire if we are not the successful Bidder, upon the earlier of:
 - (a) Our receipt of a copy of your notification of the name of the successful Bidder; or
 - (b) Thirty days after the expiration of our Tender.
4. I/We understand that if I am/we are/in a Joint Venture, the Bid Securing Declaration must be in the name of the Joint Venture that submits the bid, and the Joint Venture has not been legally constituted at the time of bidding, the Bid Securing Declaration shall be in the names of all future partners as named in the letter of intent.

Signed:.....

Capacity / Title (Director/Partner/Sole proprietor, etc.)

Name:

Duly authorized to sign the bid for and on behalf of: [insert complete name of Bidder]

Dated on day of, [Insert date of signing]

Seal or stamp.

SECTION 5: INSTRUCTIONS TO TENDERERS

TABLE OF CONTENTS:

1. GENERAL	6
2. TENDER DOCUMENTS	8
3. PREPARATION OF TENDERS	8
4. SUBMISSION OF TENDERS	9
5. TENDER OPENING AND EVALUATION	10
6. AWARD OF CONTRACT	12

INSTRUCTIONS TO TENDERERS:

General:

- 1.1 The Employer as defined in the Appendix to Conditions of Contract invites tenders for Works Contract as described in the tender documents. The successful Tenderer will be expected to complete the Works by the Intended Completion Date specified in the said Appendix.
- 1.2 Tenderers shall include the following information and documents with their tenders, unless otherwise stated:
 - (a) Certified copy of Certificate of Incorporation or business registration.
 - (b) Registration with National Construction Authority for the applicable class and valid practising license at the date of tender of submission.
 - (c) PIN registration Certificate.
 - (d) VAT registration Certificate.
 - (e) Valid Tax Compliance Certificate.
 - (f) Copies of certificates of registration and principal place of business.
 - (g) Copy of CR 12 and LDs of Directors.
 - (h) AGPO Certificate for the special group issued by the National Treasury.
 - (i) Authority to seek references from the Tenderer's bankers.
 - (j) Current litigation information.
 - (k) Signed & stamped power of attorney
 - (l) Signed & stamped bill of quantities
 - (m) Experience in works of a similar nature and size for each of the last two years and clients who may be contacted for further information on these contracts;
 - (n) Qualifications and experience of key site management and technical personnel proposed for the Contract.
 - (o) Bank account in contractors' name/bank statement for the last three month.
 - (p) Serialization of all pages of bid document.
 - (q) Major items of construction equipment owned/leased
 - (r) Thirty party insurance(should be submitted 7days before issuance of the order to commence)
- 1.3 The Tenderer shall bear all costs associated with the preparation and submission of his tender, and the Employer will in no case be responsible or liable for those costs.
- 1.4 The Tenderer, at the Tenderer's own responsibility and risk, is encouraged to visit and examine the Site of the Works and its surroundings, and obtain all information that may be necessary for preparing the tender and entering into a contract for construction of the Works. The costs of visiting the Site shall be at the Tenderer's own expense.
- 1.5 The procurement entity's employees, committee members, board members and their relative (spouse and children) are not eligible to participate in the tender.
- 1.6 Bidders however can download tender documents from our website: www.kerra.go.ke free of charge.
- 1.7 The procuring entity shall allow the tenderer to review the tender document free of charge before purchase.

2. **Tender Documents:**

- 2.1 The complete set of tender documents comprises the documents listed here below and any addition in accordance with clause,
- (a) **Instructions to Tenderers.**
 - (b) **Form of Tender.**
 - (c) **Conditions of Contract and Appendix to Form of Agreement.**
 - (d) **Specifications.**
 - (e) **Drawings.**
 - (f) **Bills of Quantities.**
 - (g) **Other materials required to be filled and submitted in accordance with these Instructions and Conditions.**
- 2.2 The Tenderer shall examine all instructions, forms and specifications in the tender documents. Failure to furnish all information required by the tender documents may result in rejection of his tender.
- 2.3 A prospective Tenderer making inquiry of the tendering documents may notify the Employer in writing or by cable, telex or facsimile at the address indicated in the letter of invitation to tender. The Employer will respond to any request for clarification received earlier than seven [7] days prior to the deadline for submission of tenders. Copies of the Employer's response will be forwarded to all persons issued with tendering documents, including a description of the inquiry, but without identifying its source.
- 2.4 Before the deadline for submission of tenders, the Employer may modify the tendering documents by issuing addenda. Any addendum thus issued shall be part of the tendering documents and shall be communicated in writing or by cable, telex or facsimile to all Tenderers. Prospective tenderers shall acknowledge receipt of each addendum in writing to the Employer.
- 2.5 To give prospective Tenderers reasonable time in which to take an addendum into account in preparing their tenders, the Employer shall extend, as necessary, the deadline for submission of tenders in accordance with clause 4.2 here below.

3. **Preparation of Tenders:**

- 3.1 All documents relating to the tender and any correspondence shall be in English Language.
- 3.2 The tender submitted by the Tenderer shall comprise the following: -
- (a) The Tender;
 - (b) **Tender Security;**
 - (c) Priced Bill of Quantities for lump-sum Contracts.
 - (d) Any other materials required to be completed and submitted by Tenderers.
- 3.3 The Tenderer shall fill in rates and prices for all items of the Works described in the Bill of Quantities. Items for which no rate or price is entered by the Tenderer will not be paid for when executed and shall be deemed covered by the other rates and prices in the Bill of Quantities.
- 3.4 All duties, taxes and other levies payable by the Contractor under the Contract, as of 30 days prior to the deadline for submission of tenders, shall be included in the tender price submitted by the Tenderer.
- 3.5 The rates and prices quoted by the Tenderer shall not be subject to any adjustment during the performance of the Contract.

- 3.6 The unit rates and prices shall be in **Kenya Shillings**.
- 3.7 Tenders shall remain valid for a period of **One Hundred Twenty (120)** days from the date of submission or according to Appendix to the form of tender. However, in exceptional circumstances, the Employer may request that the Tenderers extend the period of validity for a specified additional period. The request and the Tenderers' responses shall be made in writing.
- 3.8 The Tenderer shall prepare one original of the documents comprising the tender documents as described in these Instructions to Tenderers.
- 3.9 The original shall be typed or written in indelible ink and shall be signed by a person or persons duly authorized to sign on behalf of the Tenderer. All pages of the tender where alterations or additions have been made shall be initialed by the person or persons signing the tender.
- 3.10 Clarification of tenders shall be requested by the tenderer to be received by the procuring entity not later than 7 days prior to the deadline for submission of tenders.
- 3.11 The procuring entity shall reply to any clarifications sought by the tenderer within **7 days** of receiving the request to enable the tenderer to make timely submission of its tender.

4. Submission of Tenders:

- 4.1 The tender duly filled and sealed in an envelope shall; -
- (a) Be addressed to the Employer at the address provided in the invitation to tender;
 - [b] Bear the name and identification number of the Contract as defined in the invitation to tender and
 - [c] Provide a warning not to open before the specified time and date for tender opening.
- 4.2 Tenders shall be delivered to the Employer at the address specified above not later than the time and date specified in the invitation to tender.
- 4.3 The tenderer shall not submit any alternative offers unless they are specifically required in the tender documents.
- 4.4 Only one tender may be submitted by each tenderer.
- 4.5 Any tenderer who fails to comply with this requirement will be disqualified.
- 4.4 Any tender received after the deadline for opening tenders will be returned to the tenderer unopened.
- 4.5 The Employer may extend the deadline for submission of tenders by issuing an amendment in accordance with sub-clause 2.5 in which case all rights and obligations of the Employer and the Tenderers previously subject to the original deadline will then be subject to the new deadline.

5. Tender Opening and Evaluation:

- 5.1 The tenders will be opened in the presence of the Tenderers' representatives who choose to attend at the time and in the place specified in the invitation to tender.
- 5.2 The Tenderers' names, the total amount of each tender and such other details as may be considered appropriate, will be announced at the opening by the Employer. Minutes of the tender opening, including the information disclosed to those present will also be prepared by the Employer.
- 5.3 Information relating to the examination, clarification, evaluation and comparison of tenders and recommendations for the award of the Contract shall not be disclosed to Tenderers or any other persons not officially concerned with such process until the award to the successful Tenderer has been announced.
- 5.4 Any effort by a Tenderer to influence the Employer's officials, processing of tenders or award decisions may result in the rejection of his tender.

- 5.4 Tenders determined to be substantially responsive will be checked for any arithmetic errors. Errors will be corrected as follows:
- (a) where there is a discrepancy between the amount in figures and the amount in words, the amount in words will prevail; and
 - (b) Where there is a discrepancy between the unit rate and the line item total resulting from multiplying the unit rate by the quantity, the unit rate as quoted will prevail, unless in the opinion of the Employer's representative, there is an obvious typographical error, in which case the adjustment will be made to the entry containing that error.
 - (c) In the event of a discrepancy between the tender amount as stated in the Form of Tender and the corrected tender figure in the main summary of the Bill of Quantities/Quotation, the amount as stated in the Form of Tender shall prevail.
 - (d) The Error Correction Factor shall be computed by expressing the difference between the tender amount and the corrected tender sum as a percentage of the Corrected Builder's Work (i.e. corrected tender sum less P.C. and Provisional Sums).
 - (e) The Error Correction Factor shall be applied to all Builder's Work (as a rebate or addition as the case may be) for the purposes of valuations for Interim Certificates and valuation of variations.
 - (f) The amount stated in the tender will be adjusted in accordance with the above procedure for the correction of errors and with concurrence of the Tenderer, shall be considered as binding upon the Tenderer. If the Tenderer does not accept the corrected amount, the tender may be rejected and the Tender Security forfeited.
- 5.5 The tender evaluation committee shall evaluate the tender within 30 days of the validity period from the date of opening the tender.
- 5.6 Contract price variations shall not be allowed for contracts not exceeding one year (12 months)
- 5.7 Where contract price variation is allowed, the valuation shall not exceed 25% of the original contract price.
- 5.8 Price variation requests shall be processed by the procuring entity within 30 days of receiving the request.

- 5.9 To assist in the examination, evaluation, and comparison of tenders, the Employer at his discretion, may request [in writing] any Tenderer for clarification of the tender, including breakdowns of unit rates. The request for clarification and the response shall be in writing or by cable, telex or facsimile but no change in the tender price or substance of the tender shall be sought, offered or permitted.
- 5.10 The Tenderer shall not influence the Employer on any matter relating to his tender from the time of the tender opening to the time the Contract is awarded. Any effort by the Tenderer to influence the Employer or his employees in his decision on tender evaluation, tender comparison or Contract award may result in the rejection of the tender.

6. Award of Contract:

- 6.1 The award of the Contract will be made to the Tenderer who has offered the lowest evaluated tender price.
- 6.2 Notwithstanding the provisions of clause 6.1 above, the Employer reserves the right to accept or reject any tender and to cancel the tendering process and reject all tenders at any time prior to the award of Contract without thereby incurring any liability to the affected Tenderer or Tenderers or any obligation to inform the affected Tenderer or Tenderers of the grounds for the action.
- 6.3 The Tenderer whose tender has been accepted will be notified of the award prior to expiration of the tender validity period in writing or by cable, telex or facsimile. This notification (hereinafter and in all Contract documents called the "Letter of Acceptance") will state the sum [hereinafter and in all Contract documents called the "Contract Price" which the Employer will pay the Contractor in consideration of the execution, completion, and maintenance of the Works by the Contractor as prescribed by the Contract. The contract shall be formed on the parties signing the contract. At the same time the other tenderers shall be informed that their tenders have not been successful.
- 6.4 The Contract Agreement will incorporate all agreements between the Employer and the successful Tenderer. It will be signed by the Employer and sent to the successful Tenderer, within 30 days following the notification of award. Within 21 days of receipt, the successful Tenderer will sign the Agreement and return it to the Employer.

- 6.5 Within 21 days after receipt of the Letter of Acceptance, the successful Tenderer shall deliver to the Employer a Performance Security amount stipulated in the Appendix to Conditions of Contract.
- 6.6 The parties to the contract shall have it signed within 30 days from the date of notification of contract award unless there is an administrative review request.
- 6.7 The procuring entity may at any time terminate procurement proceedings before contract award and shall not be liable to any person for the termination.
- 6.8 The procuring entity shall give prompt notice of the termination to the tenderers and on request give its reasons for termination within 14 days of receiving the request from any tenderer.

7. Corrupt and fraudulent practices:

- 7.1 The procuring entity requires that the tenderer observes the highest standard of ethics during the procurement process and execution of the contract. A tenderer shall sign a declaration that he has not and will not be involved in corrupt and fraudulent practices.
- 7.2 The procuring entity will reject a tender if it determines that the tenderer recommended for award has engaged in corrupt and fraudulent practices in competing for the contract in question.
- 7.3 Further a tenderer who is found to have indulged in corrupt and fraudulent practices risks being debarred from participating in public procurement in Kenya.

SECTION 6: QUALIFICATION CRITERIA

Qualification Criteria			Compliance Requirements	Documentation
No.	Subject	Requirement	Single Entity	Submission Requirements
1. Eligibility				
1.1	Eligibility	Nationality in accordance with Confidential Business Questionnaire in the standard forms	Must meet requirement.	Refer to standard form section 7
1.4	Incorporation & Registration	<p>Pursuant to sub clause 1.2 the following shall be provided;</p> <p>- Certified Copy of Certificate of incorporation to show that the applicant is a registered company and legally authorised to do business in Kenya</p> <p>-Proof of registration with the National Construction Authority Category NCA 7or 8 and above for Road Works.</p>	Must meet requirement.	Refer to standard form section 7

Qualification Criteria			Compliance Requirements	Documentation
No.	Subject	Requirement	Single Entity	Submission Requirements
2.1	History of Non-Performing Contracts:	Non-performance of a contract did not occur within the last Three (3) years prior to the deadline for application submission based on all information on fully settled disputes or litigation. A fully settled dispute or litigation is one that has been resolved in accordance with the Dispute Resolution Mechanism under the respective contract, and where all appeal instances available to the applicant have been exhausted.	Must meet requirement by itself or as party to past.	
2.2	Pending Litigation.	All pending litigation shall in total not represent more than fifty percent (50%) of the Applicant's net worth and shall be treated as resolved against the Applicant.	Must meet requirement by itself or as party to past.	Refer to standard form section 7
3.1	Financial Performance.	Submission of audited balance sheets or if not required by the law of the applicant's country, other financial statements acceptable to the Employer, for the last two [2] years to demonstrate: (a) the current soundness of the applicants financial	(a) NA. (b) Bank account/bank statement may act as a proof.	Refer to standard form section 7

Qualification Criteria			Compliance Requirements	Documentation
No.	Subject	Requirement	Single Entity	Submission Requirements
		position and its prospective long term profitability, and (b) capacity to have a cash flow amount		
3.2	Average Annual Construction Turnover:	Minimum average annual construction turnover of Kshs 500,000.00.(Five hundred thousand only), calculated as total certified payments received for contracts in progress or completed, within the last two(2) years	Must meet requirement.	Refer to standard form section 7
4.1	General Construction Experience:	Experience under construction contracts in the role of contractor, subcontractor, or management contractor for at least the last 2 years prior to the applications submission deadline	Must meet requirement.	Refer to standard form section 7
4.2(a)	Specific Construction Experience:	Participation as contractor, management contractor or subcontractor, in at least two (2) contracts within the last three (3) years, each with a value of at least KShs.500,000.00 (Five hundred thousand), that have been successfully and substantially completed and that are similar to the	Must meet requirement	Refer to standard form section 7

Qualification Criteria			Compliance Requirements	Documentation
No.	Subject	Requirement	Single Entity	Submission Requirements
		proposed works. The similarity shall be based on the physical size, complexity, methods/technology or other characteristics as described in Scope of Works		
4.2(b)		b) For the above or other contracts executed during the period stipulated in 4.2(a) above, a minimum construction experience in at least one (1) of: <ul style="list-style-type: none"> -Routine maintenance - Spot improvement & rehabilitation works. 	Must meet requirements	Refer to standard form section 7
4.3	Work Methodology:	Submission of a brief work methodology	Should demonstrate understanding of the scope of works and other general requirements	Refer to standard form section 7
5. Equipment Holding				
5.1	Minimum number of Equipment:	The bidder must indicate and provide proof of ownership or leasing of different core plant/equipment.	Must meet requirement	Refer to standard form section 7

Qualification Criteria			Compliance Requirements	Documentation
No.	Subject	Requirement	Single Entity	Submission Requirements
		Necessary for undertaking the project to completion within the completion time.		
6. Current Commitment				
6.1	On-going contracts:	The total value of current works on the on-going contracts must not exceed Kshs. 3 million.	Must meet requirements	
7. Site Staff				
1	Site Agent:	The site staff shall possess minimum levels set below;	Site agent and senior foreman are mandatory	Refer to guideline notes
2	Foremen (2 No.)	<p>Qualification = Dip in civil Eng. General Experience = 3 yrs Specific Experience = 2 yrs</p> <p>Qualification = Diploma civil Eng General Experience = 3 yrs Specific Experience = 2 yrs</p>		

DISCLAIMER: Newly formed firms shall not be required to provide experience & bank statement but will be required to tender for **works below Kshs. 3million.**

SECTION 7: CONDITIONS OF CONTRACT

Table of Clauses:		Page
1.	DEFINITIONS.....	20
2.	CONTRACT DOCUMENTS.....	21
3.	EMPLOYER’S REPRESENTATIVE’S DECISIONS.....	21
4.	WORKS, LANGUAGE AND LAW OF CONTRACT.....	22
5.	SAFETY, TEMPORARY WORKS AND DISCOVERIES.....	22
6.	WORK PROGRAM AND SUB-CONTRACTING.....	22
7.	THE SITE.....	22
8.	INSTRUCTIONS.....	23
9.	EXTENSION OF COMPLETION DATE.....	23
10.	MANAGEMENT MEETINGS.....	24
11.	DEFECTS.....	24
12.	BILLS OF QUANTITIES.....	25
13.	VARIATIONS.....	25
14.	PAYMENT CERTIFICATES AND FINAL ACCOUNT	26
15.	INSURANCES	27
16.	LIQUIDATED DAMAGES.....	27
17.	COMPLETION AND TAKING OVER.....	27
18.	TERMINATION.....	27
19.	PAYMENT UPON TERMINATION.....	28
20.	CORRUPT GIFTS AND PAYMENTS OF COMMISSION.....	28
21.	SETTLEMENT OF DISPUTES.....	29

CONDITIONS OF CONTRACT

1. Definitions:

1.1 In this Contract, except where context otherwise requires, the following terms shall be interpreted as indicated;

“Bills of Quantities” means the priced and completed Bill of Quantities forming part of the tender [where applicable].

“Schedule of Rates” means the priced Schedule of Rates forming part of the tender [where applicable].

“The Completion Date” means the date of completion of the Works as certified by the Employer’s Representative.

“The Contract” means the agreement entered into by the Employer and the Contractor as recorded in the Agreement Form and signed by the parties.

“The Contractor” refers to the person or corporate body who’s tender to carry out the Works has been accepted by the Employer.

“The Contractor’s Tender” is the completed tendering document submitted by the Contractor to the Employer.

“The Contract Price” is the price stated in the Letter of Acceptance.

“Days” are calendar days; **“Months”** are calendar months.

“A Defect” is any part of the Works not completed in accordance with the Contract.

“The Defects Liability Certificate” is the certificate issued by Employer’s Representative upon correction of defects by the Contractor.

“The Defects Liability Period” is the period named in the Appendix to Conditions of Contract and calculated from the Completion Date.

“Drawings” include calculations and other information provided or approved by the Employer’s Representative for the execution of the Contract.

“Employer” Includes Central or Local Government administration, Universities, Public Institutions and Corporations and is the party who employs the Contractor to carry out the Works.

“Equipment” is the Contractor’s machinery and vehicles brought temporarily to the Site for the execution of the Works.

“Site” means the place or places where the permanent Works are to be carried out including workshops where the same is being prepared.

“Materials” are all supplies, including consumables, used by the Contractor for incorporation in the Works.

“Employer’s Representative” is the person appointed by the Employer and notified to the Contractor for the purpose of supervision of the Works.

“Specification” means the Specification of the Works included in the Contract.

“Start Date” is the date when the Contractor shall commence execution of the Works.

“A Subcontractor” is a person or corporate body who has a Contract with the Contractor to carry out a part of the Work in the Contract, which includes Work on the Site.

“Temporary works” are works designed, constructed, installed, and removed by the Contractor which are needed for construction or installation of the Works.

“A Variation” is an instruction given by the Employer’s Representative which varies the Works.

“The Works” are what the Contract requires the Contractor to construct, install, and turnover to the Employer.

2. Contract Documents:

2.1 The following documents shall constitute the Contract documents and shall be interpreted in the following order of priority;

- (1) Agreement,
- (2) Letter of Acceptance,
- (3) Contractor’s Tender,
- (4) Conditions of Contract,
- (5) Specifications,
- (6) Drawings,
- (7) Bills of Quantities.

3. Employer's Representative's Decisions:

3.1 Except where otherwise specifically stated, the Employer's Representative will decide contractual matters between the Employer and the Contractor in the role representing the Employer.

4. Works, Language and Law of Contract:

4.1 The Contractor shall construct and install the Works in accordance with the Contract documents. The Works may commence on the Start Date and shall be carried out in accordance with the Program submitted by the Contractor, as updated with the approval of the Employer's Representative, and complete them by the Intended Completion Date.

4.2 The ruling language of the Contract shall be English language and the law governing the Contract shall be the law of the Republic of Kenya.

5. Safety, Temporary works and Discoveries:

5.1 The Contractor shall be responsible for design of temporary works and shall obtain approval of third parties to the design of the temporary works where required.

5.2 The Contractor shall be responsible for the safety of all activities on the Site.

5.3 Anything of historical or other interest or significant value unexpectedly discovered on the Site shall be the property of the Employer. The Contractor shall notify the Employer's Representative of such discoveries and carry out the Employer's Representative's instructions for dealing with them.

6 Work Program and Sub-contracting:

6.1 Within seven days after Site possession date, the Contractor shall submit to the Employer's Representative for approval a program showing the general methods, arrangements, order and timing for all the activities in the Works.

6.2 The Contractor may sub-contract the Works (but only to a maximum of 25 percent of the Contract Price) with the approval of the Employer's Representative. However, he shall not assign the Contract without the approval of the Employer in writing. Sub-contracting shall not alter the Contractor's obligations.

7 The site:

7.1 The Employer shall give possession of all parts of the Site to the Contractor.

7.2 The Contractor shall allow the Employer's Representative and any other person authorized by the Employer's Representative, access to the Site and to any place where work in connection with the Contract is being carried out or is intended to be carried out.

8 Instructions:

8.1 The Contractor shall carry out all instructions of the Employer's Representative which are in accordance with the Contract.

9 Extension of Completion Date:

9.1 The Employer's Representative shall extend the Completion Date if an occurrence arises which makes it impossible for completion to be achieved by the Intended Completion Date. The Employer's Representative shall decide whether and by how much to extend the Completion Date.

9.2 For the purposes of this clause, the following occurrences shall be valid for consideration;

Delay by: (a) force majeure, or

(b) reason of any exceptionally adverse weather conditions, or

(c) reason of civil commotion, strike or lockout affecting any of the trades employed upon the Works or any of the trades engaged in the preparation, manufacture or transportation of any of the goods or materials required for the Works, or

(d) reason of the Employer's Representative's instructions issued under these Conditions, or

(e) reason of the contractor not having received in due time necessary instructions, drawings, details or levels from the Employer's Representative for which he specifically applied in writing on a date which having regard to the date for Completion stated in the appendix to these Conditions or to any extension of time then fixed under this clause was neither unreasonably distant from nor unreasonably close to the date on which it was necessary for him to receive the same, or

(f) delay on the part of artists, tradesmen or others engaged by the Employer in executing work not forming part of this Contract, or

- (g) Reason of delay by statutory or other services providers or similar bodies engaged directly by the Employer, or
- (h) reason of opening up for inspection of any Work covered up or of the testing or any of the Work, materials or goods in accordance with these conditions unless the inspection or test showed that the Work, materials or goods were not in accordance with this Contract, or
- (i) Reason of delay in appointing a replacement Employer's Representative, or
- (j) reason of delay caused by the late supply of goods or materials or in executing Work for which the Employer or his agents are contractually obliged to supply or to execute as the case may be, or
- (k) Delay in receiving possession of or access to the Site.

10 Management Meetings:

- 10.1 A Contract management meeting shall be held regularly and attended by the Employer's Representative and the Contractor. Its business shall be to review the plans for the remaining Work. The Employer's Representative shall record the business of management meetings and provide copies of the record to those attending the meeting and the Employer. The responsibility of the parties for actions to be taken shall be decided by the Employer's Representative either at the management meeting or after the management meeting and stated in writing to all who attend the meeting.
- 10.2 Communication between parties shall be effective only when in writing.

11 Defects:

- 11.1 The Employer's Representative shall inspect the Contractor's work and notify the Contractor of any defects that are found. Such inspection shall not affect the Contractor's responsibilities. The Employer's Representative may instruct the Contractor to search for a defect and to uncover and test any Work that the Employer's Representative considers may have a defect. Should the defect be found, the cost of uncovering and making good shall be borne by the Contractor. However if there is no defect found, the cost of uncovering and making good shall be treated as a variation and added to the Contract Price.
- 11.2 The Employer's Representative shall give notice to the Contractor of any defects before the end of the Defects Liability Period, which begins

at Completion, and is defined in the Appendix to Form of Agreement.

11.3 Every time notice of a defect is given, the Contractor shall correct the notified defect within the length of time specified by the Employer's Representative's notice. If the Contractor has not corrected a defect within the time specified in the Employer's Representative's notice, the Employer's Representative will assess the cost of having the defect corrected by other parties and such cost shall be treated as a variation and be deducted from the Contract Price.

12 Bills of Quantities:

12.1 The Bills of Quantities shall contain items for the construction, installation, testing and commissioning of the Work to be done by the Contractor. The Contractor will be paid for the quantity of the Work done at the rates in the Bills of Quantities for each item. Items against which no rate is entered by the Tenderer will not be paid for when executed and shall be deemed covered by the rates for other items in the Bills of Quantities.

12.2 Where Bills of Quantities do not form part of the Contract, the Contract Price shall be a lump sum (which shall be deemed to have been based on the rates in the Schedule of Rates forming part of the tender) and shall be subject to re-measurement after each stage.

13 Variations:

13.1 The Contractor shall provide the Employer's Representative with a quotation for carrying out the variations when requested to do so. The Employer's Representative shall assess the quotation and shall obtain the necessary authority from the Employer before the variation is ordered.

13.2 If the Work in the variation corresponds with an item description in the Bill of Quantities, the rate in the Bill of Quantities shall be used to calculate the value of the variation. If the nature of the Work in the variation does not correspond with items in the Bill of Quantities, the quotation by the Contractor shall be in the form of new rates for the relevant items of Work.

13.3 If the Contractor's quotation is unreasonable, the Employer's Representative may order the variation and make a change to the Contract Price, which shall be based on the Employer's Representative's own forecast of the effects of the variation on the Contractor's costs.

14 Payment Certificates and Final Account:

- 14.1 The Contractor shall be paid based on re-measurement by the Employer's representative of the work done in case of lump-sum Contracts, the valuation for each stage shall be based on the quantities so obtained in the re-measurement and the rates in the Bill of Quantities.
- 14.2 Upon deciding that Works included in a particular stage are complete, the Contractor shall submit to the Employer's Representative his application for payment. The Employer's Representative shall check, adjust if necessary and certify the amount to be paid to the Contractor within 21 days of receipt of the Contractor's application. The Employer shall pay the Contractor the amounts so certified within 30 days of the date of issue of each Interim Certificate.
- 14.3 The Contractor shall supply the Employer's Representative with a detailed final account of the total amount that the Contractor considers payable under the Contract before the end of the Defects Liability Period. The Employer's Representative shall issue a Defect Liability Certificate and certify any final payment that is due to the Contractor within 30 days of receiving the Contractor's account if it is correct and complete. If it is not, the Employer's Representative shall issue within 21 days a schedule that states the scope of the corrections or additions that are necessary. If the final account is still unsatisfactory after it has been resubmitted, the Employer's Representative shall decide on the amount payable to the Contractor and issue a Final Payment Certificate. The Employer shall pay the Contractor the amount so certified within 60 days of the issue of the Final Payment Certificate.
- 14.4 If the period laid down for payment to the Contractor upon each of the Employer's Representative's Certificate by the Employer has been exceeded, the Contractor shall be entitled to claim simple interest calculated pro-rata on the basis of the number of days delayed at the

Central Bank of Kenya's average base lending rate prevailing on the first day the payment becomes overdue. The Contractor will be required to notify the Employer within 15 days of receipt of delayed payments of his intentions to claim interest.

15. Insurance:

15.1 The Contractor shall be responsible for and shall take out appropriate cover against, among other risks, personal injury; loss of or damage to the Works, materials and plant; and loss of or damage to property.

16. Liquidated Damages:

16.1 The Contractor shall pay liquidated damages to the Employer at the rate 0.001 per cent of the Contract price per day for each day that the actual Completion Date is later than the Intended Completion Date except in the case of any of the occurrences listed under clause 9.2. The Employer may deduct liquidated damages from payments due to the Contractor. Payment of liquidated damages shall not affect the Contractor's liabilities.

17. Completion and Taking Over:

17.1 Upon deciding that the Work is complete the Contractor shall request the Employer's Representative to issue a Certificate of Completion of the Works, upon deciding that the Work is completed.

The Employer shall take over the Site and the Works within seven days of the Employer's Representative issuing a Certificate of Completion.

18. Termination:

18.1 The Employer or the Contractor may terminate the Contract if the other party causes a fundamental breach of the Contract. These fundamental breaches of Contract shall include, but shall not be limited to, the following;

- (a) the Contractor stops Work for 30 days continuously without reasonable cause or authority from the Employer's Representative;
- (b) the Contractor is declared bankrupt or goes into liquidation other than for a reconstruction or amalgamation;
- (c) a payment certified by the Employer's Representative is not paid by the Employer to the Contractor within 30 days after the expiry of the payment periods stated in sub clauses 14.2 and 14.3 hereinabove.

- (d) the Employer's Representative gives notice that failure to correct a particular defect is a fundamental breach of Contract and the Contractor fails to correct it within a reasonable period of time.

18.2 If the Contract is terminated, the Contractor shall stop Work immediately, and leave the Site as soon as reasonably possible. The Employer's Representative shall immediately thereafter arrange for a meeting for the purpose of taking record of the Works executed and materials, goods, equipment and temporary buildings on Site.

19. Payment upon Termination:

19.1 The Employer may employ and pay other persons to carry out and complete the Works and to rectify any defects and may enter upon the Works and use all materials on Site, plant, equipment and temporary works.

19.2 The Contractor shall, during the execution or after the completion of the Works under this clause, remove from the Site as and when required within such reasonable time as the Employer's Representative may in writing specify, any temporary buildings, plant, machinery, appliances, goods or materials belonging to him, and in default thereof, the Employer may (without being responsible for any loss or damage) remove and sell any such property of the Contractor, holding the proceeds less all costs incurred to the credit of the Contractor.

19.3 Until after completion of the Works under this clause, the Employer shall not be bound by any other provision of this Contract to make any payment to the Contractor, but upon such completion as aforesaid and the verification within a reasonable time of the accounts therefor the Employer's Representative shall certify the amount of expenses properly incurred by the Employer and, if such amount added to the money paid to the Contractor before such determination exceeds the total amount which would have been payable on due completion in accordance with this Contract, the difference shall be a debt payable to the Employer by the Contractor; and if the said amount added to the said money be less than the said total amount, the difference shall be a debt payable by the Employer to the Contractor.

20. Corrupt Gifts and Payments of Commission:

20.1 The Contractor shall not;

- (a) Offer or give or agree to give to any person in the service of the Employer any gifts or consideration of any kind as an inducement or reward for doing or forbearing to do or for having done or forborne to do any act in relation to the obtaining or execution of this or any other contract with the Employer or for

Showing or forbearing to show favour or disfavour to any person in relation to this or any other contract with the Employer.

- (b) Any breach of this Condition by the Contractor or by anyone employed by him or acting on his behalf (whether with or without the knowledge of the Contractor) shall be an offence under the Laws of Kenya.

21. Settlement of Disputes:

- 21.1 Any dispute arising out of the Contract which cannot be amicably settled between the parties shall be referred by either party to the arbitration and final decision of a person to be agreed between the parties. Failing agreement to concur in the appointment of an Arbitrator, the Arbitrator shall be appointed by the chairman of the Chartered Institute of Arbitrators, Kenya branch, on the request of the applying party.

SECTION 8: APPENDIX TO FORM OF AGREEMENT

This Appendix to Form of Agreement forms part of the Agreement.

Item	Data
Time for Completion	2 Months
Priority of Documents	<p>The documents forming the Contract shall be interpreted in the following order of priority:</p> <ul style="list-style-type: none"> • The Contract Agreement and Appendix to form of agreement. • The Letter of Acceptance. • The Form of Tender. • The Conditions of Contract, Part II - Conditions of Particular application. • The Conditions of Contract, Part I – General Conditions of Contract • The Specifications. • The Drawings. • The Priced Bill of Quantities.
Law of Contract	Laws of the Republic of Kenya.
Language	English.
Provision of Site	On Commencement Date.
Name and Address of Employer	Director General, Kenya Rural Roads Authority, P.O. Box 48151-00100, Nairobi.
Authorised Person	General Manager (Maintenance), Kenya Rural Roads Authority, P.O. Box 48151-00100, Nairobi.
Name and Address of the Engineer	Regional Manager, Kenya Rural Roads Authority, P. O. Box 113-30500, Turkana.
Name and Address of Engineer's Representative	Constituency Roads Officer, (Turkana West/Turkana North/Turkana Central/Turkana South/ Turkana East&Loima Constituency (Turkana Region).
Penalty to the Contractor for Employer paying workers on his behalf	10% of the amount paid to the workers.
Performance Security	(Refer to guideline Notes)
Amount	0.001% of sum stated as the Contract Price
Form	Bank Guarantee or Insurance Bond issued by the bank or insurance company approved by PPRA approved insurance companies
Requirements of Contractors Design	N/A

Item	Data
Programme ⇒ Time of Submission	N/A Within 7days of Commencement Date
⇒ Form of Programme	Bar Chart
⇒ Interval Updates	As requested by the RM
Liquidated Damages Amount payable due to failure to complete	0.01% of Contract Price per Day to a limit of 1% of Contract Price.
Defects Liability Period	N/A
Period of notifying defects	N/A
Percentage of Retention	N/A
Bid Security Amount	N/A
Valuation of Works	Re-measurements with Bills of Quantities
Repayment Schedule for Advance Payment	-. N/A
Minimum Amount of Interim Payment	N/A
Currency of Payment	Kenya Shilling
Rate of Interest	Simple Interest at a rate of 2% above mean base lending rate as issued by the Central Bank of Kenya.
Insurance	Required
Arbitration ⇒ Rules ⇒ Appointing Authority Place of Arbitration	CAP 49 of the Laws of Kenya Chairman Chartered Institute of Arbitrators, Kenya Branch. Kenya Rural Roads Authority, Headquarters

SECTION 9: STANDARD FORMS

SCHEDULES OF SUPPLEMENTARY INFORMATION

SCHEDULE 1: CONFIDENTIAL BUSINESS QUESTIONNAIRE32
SCHEDULE 2: FORM OF WRITTEN POWER OF ATTORNEY35
SCHEDULE 3: CERTIFICATE OF BIDDER’S VISIT TO SITE36
SCHEDULE 4: SCHEDULE OF BASIC RATES OF MATERIALS.....36
SCHEDULE 5: KEY PERSONNEL.....37
SCHEDULE 6: SCHEDULE OF ROADWORKS CARRIED OUT BY THE
BIDDER IN THE LAST FIVE YEARS38
SCHEDULE 7: SCHEDULE OF ONGOING PROJECTS39
SCHEDULE 8: SCHEDULE OF LOCAL LABOUR BASIC RATES40
SCHEDULE 9: FINANCIAL STANDING.....41
SCHEDULE 10: OTHER SUPPLEMENTARY INFORMATION.....42
SCHEDULE 11: WORK METHODOLOGY.....44

SCHEDULE 1: CONFIDENTIAL BUSINESS QUESTIONNAIRE:

CONFIDENTIAL BUSINESS QUESTIONNAIRE:

You are requested to give the particulars indicated in Part 1 and either Part 2 (a), 2(b) or 2(c) Whichever applies to your type of business?
You are advised that it is a serious offence to give false information on this Form.

Part 1 - General:

Business name:

.....

Location of business premises:

.....
Plot No. Street/Road.....
Postal Address.....Tel No.
Nature of business.....
.....

Current Trade Licence No:Expiring date:
Maximum value of business which you can handle at any one time:
Kshs.....
Name of your bankers:
Branch.....
Are you an agent of the Kenya National Trading Corporation? YES/NO
Part 2(a) - Sole Proprietor:

Your name in full:
.....
Age.....
NationalityCountry of origin:
*Citizenship details:

Part 2(b) - Partnership:

Give details of partners as follows:

Name	Nationality	Citizenship Details*	Shares
1.....			
2.....			
3.....			
4.....			
5.....			

Part 2(c) - Registered Company:

Private or public.....

State the nominal and issued capital of the company-

Nominal Kshs.....

Issued Kshs.....

Give details of all directors as follows:

Name	Nationality	Citizenship Details*	Shares
------	-------------	----------------------	--------

1.....			
--------	--	--	--

2.....			
--------	--	--	--

3.....			
--------	--	--	--

4.....			
--------	--	--	--

5.....			
--------	--	--	--

Part 2(d) Interest in the Firm:

Is there any person/persons in the Kenya Rural Roads Authority who has interest in this firm?

Yes/No**

.....
Date

.....
Signature of Bidder

Attach proof of citizenship (Compulsory)

** Delete as necessary

SCHEDULE 2: FORM OF WRITTEN POWER OF ATTORNEY

The Bidder shall state here below the name(s) and address of his representative(s) who is/are authorized to receive on his behalf correspondence in connection with the Bid.

.....
(Name of Bidder's Representative in block letters)

.....
(Address of Bidder's Representative)

.....
(Signature of Bidder's Representative)
Alternate:

.....
(Name of Bidder's Representative in block letters)

.....
(Address of Bidder's Representative)

.....
(Signature of Bidder's Representative)

*To be filled by all Bidders.

SCHEDULE 3: CERTIFICATE OF BIDDER'S VISIT TO SITE

This is to certify that

[Name/s]

.....

Being the authorized representative/Agent of [Name of bidder]

.....

.....

participated in the organized inspection visit of the site of the works for the
Spot Improvement ofheld on**day of****20**.....

Signed.....(Employer's Representative)

.....
(Name of Employer's Representative)

.....
(Designation)

NOTE: This form is to be completed at the time of the organized site visit.

SCHEDULE 5: KEY PERSONNEL

DESIGNATION	NAME	NATIONALITY	SUMMARY OF QUALIFICATIONS AND EXPERIENCE		
			Qualifications	General Experience (Yrs)	Relevant Experience (Yrs)
Headquarters					
Partner/Director or other key staff (give designation)					
Site Agent					
Foremen 2 No					
Other Key Staff					
(i)					
(ii)					
(iii)					
(iv)					
(v)					
(vi)					
(vii)					

Note: The Bidder shall list in this schedule the key personnel he will employ from the Contractor’s headquarters and from the Contractor’s site office to direct and execute the work together with their qualifications, experience, position held and nationality in accordance with Clause 15.2 and 16.3 of the Conditions of Contract Part II (where required, use separate sheets to add extra data for column 4). Bidders shall attach signed and certified Academic certificates and CVs of all key staff.

I certify that the above information is correct.

.....
(Signature of Bidder)

.....

(Date)

SCHEDULE 7: SCHEDULE OF ONGOING PROJECTS

DESCRIPTION OF WORKS	NAME AND ADDRESS OF CLIENT	DATE OF COMMENCEMENT	DATE OF COMPLETION	VALUE OF WORKS (KSHS)	VALUE COMPLETED UP TO DATE %	PHYSICALLY COMPLETED UP TO DATE %

I certify that the above works are being carried out by me and that the above information is correct.

.....
(Signature of Bidder)

.....
(Date)

SCHEDULE 8: SCHEDULE OF LOCAL LABOUR BASIC RATES

The rates inserted in this schedule will be those used in determining changes in cost of local labour as provided in Clause 70.1 of the Conditions of Contract Part 2.

LABOUR CATEGORY	MONTH/SHIFT/HOUR	UNIT	RATE SHS

NOTE: Categories to be generally in accordance with those used by the Kenya Building Construction Engineering and Allied Trade Workers Union.

I certify that the above information is correct.

.....
Date

.....
Signature of Bidder

SCHEDULE 9: FINANCIAL STANDING

1. Submit copies of audited profit and loss statements and balance sheet for the last two calendar years and estimated projection for the next two years with certified English translation where appropriate.
2. Give turnover figures for each of the last two (2) financial years. Quote in millions and decimal thereof.

	Year 2017	Year UP TO DATE
	Kshs.	Kshs.
Roadwork's		
Other Civil Engineering Works		
Other (specify)		
Total		

SUMMARY OF ASSETS AND LIABILITIES OF THE AUDITED FINANCIAL STATEMENTS OF THE LAST TWO (2) FINANCIAL YEARS

	Year	Year
	Kshs.	Kshs.
1. Total Assets		
2. Current Assets		
3. Bank Credit Line Value		
4. Total Liabilities		
5. Current Liabilities		
6. Net Worth (1-4)		
7. Working capital (2+3-5)		

(a) Name/Address of Commercial Bank providing credit line

.....

(b) Total amount of credit line Kshs.....

Attach certified copies of financial bank statements of the last three years. Attach a certified copy of Undertaking of the Bank to providing the credit.

SCHEDULE 10: OTHER SUPPLEMENTARY INFORMATION

1. Financial reports for the last two years, balance sheets, profit and loss statements, auditors' reports etc. List them below and attach copies.

.....

.....

.....

.....

2. Evidence of access to financial resources to meet the qualification requirements. Cash in hand, lines of credit etc. List below and attach copies of supporting documents

.....

.....

.....

.....

3. Name, address, telephone, telex, fax numbers of the Bidders Bankers who may provide reference if contacted by the Contracting Authority.

.....

.....

.....

4. Information on current litigation in which the Bidder is involved.

OTHER PARTY (IES)	CAUSE OF DISPUTE	AMOUNT INVOLVED(KShs)

I certify that the above information is correct.

.....
Date

.....
Signature of Bidder

SCHEDULE 11: WORK METHODOLOGY

Give a brief description of how you intend to carry out the work including traffic management, quality assurance of works and any designs to be carried out by the Bidder, in not less than five (5) pages and not more than fifteen (15) pages.

SCHEDULE12: PROPOSED APPROPRIATE EQUIPMENT.

Mandatory minimum number of equipment required by the Employer for the execution of the project that the bidder must make available for the Contract

Item No.	Equipment Details	Minimum Number Required	No of Equipment Owned by the Bidder.	No. of equipment to be hired.
1	Pedestrian Roller – Man walk behind	-		
2	Double drum vibrating pedestrian roller(3Tons)	-		
3	Self-propelled single drum vibrating (10Tons)	-		
4	Mobile concrete mixers	-		
5	Excavator/loader	-		
6	Concrete vibrators	-		
7	Tippers payload 7 – 10 tonnes	2		
8	Flat bed lorries	-		
9	Water tankers (10,000 litres capacity)	1		
10	Grader -140H	1		

The Bidder must attach certified copies of log books or lease agreement of the following

I certify that the above information is correct.

.....
(Title)

.....
(Signature)

.....
(Date)

SECTION 10: FORM OF AGREEMENT

FORM OF AGREEMENT:

THIS AGREEMENT is made on the day of 20..... between the Director General, Kenya Rural Roads Authority of P.O.BOX 113 – 30500, Lodwar, Kenya represented by Regional Manager Turkana hereinafter called "**the Employer**" of the one part and hereinafter called the "**Contractor**" on the other part.

WHEREAS the Employer is desirous that certain works should be executed, viz.

IMPROVEMENT OF
.....

and has accepted a Bid by the Contractor for the execution, completion and maintenance of such works **NOW THIS AGREEMENT WITNESSETH** as follows:

In this agreement words and expressions shall have the same meanings as are respectively assigned to them in the Conditions of Contract hereinafter referred to. The following document shall be deemed to form and be read and construed as part of this Agreement, viz.:

- The said BID dated
- The Conditions of Contract
- The Standard and Special Specification
- The Priced Bill of Quantities
- The Letter of Acceptance
- Schedules of Supplementary Information
- The Drawings
- Other documents as may be agreed and listed

All aforesaid documents are hereinafter referred to as "The Contract".

In consideration of the payment to be made by the Employer to the Contractor, the

Contractor hereby covenants with the Employer to execute, complete and maintain the works in conformity in all respects with the provisions of the Contract.

The Employer hereby covenants to pay the Contractor in consideration of the execution, completion and maintenance of the works the Contract Price at the times and in the manner prescribed by the Contract.

IN WITNESS WHEREOF the parties hereto have caused their respective common

Seals to be hereto affixed (or have hereunto set their respective hands and seals) on the day and year first above written.

SIGNED AND DELIVERED

By the said Employer:.....
(Regional Manager – (Turkana Region), Kenya Rural Roads Authority)
For and on behalf of the said Employer.

In the presence of:.....
(Name and Designation of Witness)

.....
(Signature of Witness)

.....
(Address of witness)

By the said Contractor:

In the presence of:
(Name and Designation of Witness)

.....
(Signature of Witness)

.....
(Address of witness)

**SECTION 11: FORMS OF PERFORMANCE BANK GUARANTEE AND ADVANCE PAYMENT
GUARANTEE (UNCONDITIONAL)**

PERFORMANCE BANK GUARANTEE

To:
Director General,
Kenya Rural Roads Authority,
P.O. Box 48151 - 00100, NAIROBI.

WHEREAS (hereinafter called, **‘the Contractor’**) has undertaken in pursuance of Contract No **Dated**..... to execute the **Improvement of**
.....(hereinafter called the **‘Contract’**)

AND WHEREAS it has been stipulated by you in the said Contract that the Contractor shall furnish you with a Bank Guarantee by a recognized bank for the sum specified in the Appendix to Form of Bid as security for compliance with his obligations in accordance with the Contract;

AND WHEREAS we have agreed to give the Contractor such a Bank Guarantee;

NOW THEREFORE we hereby affirm that we are the Guarantor and responsible to you on behalf of the Contractor, up to a total of

Kshs (Amount in figures)

Kshs

..... (Amount in words)

and we undertake to payment to you, upon your first written demand and without cavil or argument, any sum or sums within and up to the limits as aforesaid without your needing to prove or show grounds or reasons for the sum specified therein.

We hereby waive the necessity of you demanding the said debt from the Contractor before presenting us with the demand.

We further agree that no change or addition to or other modification of the terms of the Contract or of the Works to be performed thereunder or of any of the Contract Documents which may be made between you and the Contractor shall in any way

release us from any liability under this Guarantee and we hereby waive notice of any such change, addition or modification
This Guarantee shall be valid until 28 days after issuing of the Taking Over Certificate.

SIGNATURE AND SEAL OF BANK

Name of Signatory

Name of **Bank**

Address.....Date

BANK GUARANTEE FOR ADVANCE PAYMENT

**To: The Director General,
Kenya Rural Road Authority,
P.O.Box 48151 – 00100, Nairobi.**

IMPROVEMENT OF.....

CONTRACT No.

Gentlemen:

In accordance with the provision of the Conditions of Contract, sub-clause 60.12(,AdvancePayment`) of the above – mentioned contract,.....(hereinafter called the ,Contractor`) shall deposit with the Director General, Kenya Rural Roads Authority a Bank Guarantee to guarantee his proper and faithful performance under the said Clause of the contract in an amount equal to ten (10) % of the contract price, i.e.

Kshs (Amount in figures)

Kshs.....(Amount in words)

We, as instructed by the Contractor, agree unconditionally and irrevocably to guarantee as primary obligator and not as Surety merely, the payment to the Director General, Kenya Rural Roads Authority on his first demand without whatsoever right of objection on our part and without his first claim to the contractor, in the amount not exceeding,

Kshs (Amount in figures)

Kshs.....(Amount in words)

We further agree that no additional to or other modification of the terms of the Contract or of the Works to be performed there under or of the Contract documents which may be made between the Director General, Kenya Rural Roads Authority and the Contractor, shall in any way release us from any liability under this guarantee, and we hereby waive notice of any change or modification.

This guarantee shall remain valid and in full effect from the date of the advance payment under the contract until the Director General, Kenya Rural Roads Authority, Nairobi, Kenya receives full payment of the same amount from the Contractor.

This guarantee shall be reduced pro rata with the deductions from the down payment made on the Interim Certificates in Accordance with Sub – Clause 60.2 of the Conditions of Contract.

Any dispute over the interpretation of the conditions of this letter of Guarantee shall be subject to the Laws of the Republic of Kenya.

After expiry, this document shall be returned to us for cancellation.

SIGNATURE AND SEAL OF BANK:

.....

Name of Signatory

Name of Bank

Address Date.....

SECTION 12: OTHER SUPPLEMENTARY REQUIREMENTS

12.1 ADJUDICATOR’S AGREEMENT

Identification of Project:

.....
(the “**Project**”)

Name and address of the Employer:

.....
(the “**Employer**”)

Name and address of the Contractor:

.....
(the “**Contractor**”)

Name and address of the Adjudicator:

.....
(the “**Adjudicator**”)

Whereas the Employer and the Contractor have entered into a Contract (“the Contract”) for the execution of the Project and wish to appoint the Adjudicator to act as adjudicator in accordance with the Rules for Adjudication [“the Rules”].

The Employer, Contractor and Adjudicator agree as follows:

1. The Rules and dispute provisions of the Contract shall form part of this Agreement.
2. The Adjudicator shall be paid:

A retainer fee ofper calendar month(where applicable)

A daily fee of

Expenses (including the cost of telephone calls, courier charges, faxes and telexes incurred in connection with his duties; all reasonable and necessary travel expenses, hotel accommodation and subsistence and other direct travel expenses).

Receipts will be required for all expenses.

3. The Adjudicator agrees to act as Adjudicator in accordance with the Rules and has disclosed to the Parties any previous or existing relationship with the Parties or others concerned with the Project.
4. This Agreement shall be governed by the laws of.....
5. The Language of this Agreement shall be

SIGNED BY.....

For and on behalf of the Employer in the presence of

Witness
 Name
 Address
 Date

SIGNED BY.....

For and on behalf of the Contractor in the presence of

Witness
 Name
 Address
 Date

SIGNED BY.....

For and on behalf of the Adjudicator in the presence of

Witness
 Name
 Address
 Date

12.2 FRAUD & CORRUPTION:

- 1 If the Employer determines that the Contractor has engaged in corrupt, fraudulent, collusive, coercive or obstructive practices, in competing for or in executing the Contract, then the Employer may, after giving 14 days notice to the Contractor, terminate the Contractor's employment under the Contract and expel him from the Site.
- 2 Should any employee of the Contractor be determined to have engaged in corrupt, fraudulent, collusive, coercive, or obstructive practice during the execution of the Works, then that employee shall be removed.
- 3 For the purposes of this Sub-Clause:
 - (i) "corrupt practice" is the offering, giving, receiving or soliciting, directly or indirectly, of anything of value to influence improperly the actions of another party;
 - (ii) "fraudulent practice" is any act or omission, including a misrepresentation, that knowingly or recklessly misleads, or attempts to mislead, a party to obtain a financial or other benefit or to avoid an obligation;
 - (iii) "collusive practice" is an arrangement between two or more parties designed to achieve an improper purpose, including to influence improperly the actions of another party;
 - (iv) "Coercive practice" is impairing or harming, or threatening to impair or harm, directly or indirectly, any party or the property of the party to influence improperly the actions of a party.
- 4 The Contractor declares that:
 - a) They did not engage in any action to influence the Project implementation process to the detriment of the Employer, in particular no collusive practice took place nor will take place, and The bidding proceedings, contract award, and execution have not and will not be subject to any corrupt practice as defined in the United Nations Convention to combat corruption dated 31 October 2003.

Dated this _____ day of _____ 20_____

Signature _____ in the capacity of _____

duly authorized to sign Tenders for and on behalf of _____ [Name of Tenderer] of

_____ [Address of Tenderer]

_____ [Seal or Stamp of Tenderer]

12.3 ENVIRONMENTAL AND SOCIAL COMMITMENT:

I have taken due note of the importance to comply with environmental and social standards and regulations.

I, the undersigned, [.....] acting as the duly authorized representative of [.....],

With respect to the submission of a bid for [.....] in accordance with the invitation to tender No [.....], I undertake to comply, and ensure that our subcontractors, if any, comply with international environmental and labour standards consistent with applicable law and regulations in the country of implementation of the Project, including the fundamental conventions of the International Labour Organisation (ILO) and international environmental treaties.

In addition, I also undertake to adopt any environmental and social risk mitigation measures as defined in the environmental and social management plan or the notice of environmental and social impact issued by the Employer.

Dated this _____ day of _____ 20_____

Signature _____ in the capacity of _____

duly authorized to sign Tenders for and on behalf of
_____ [Name of Tenderer] of

_____ [Address of Tenderer]

_____ [Seal or Stamp of Tenderer]

12.4 DECLARATION FORM:

Date _____

To _____

The tenderer i.e. (Name and address) _____
_____ Declare the following:

- a) Has not been debarred from participating in public procurement.
- b) Has not been involved in and will not be involved in corrupt and fraudulent practices regarding public procurement.

Title

Signature

Date

(To be signed by authorized representative and officially stamped)

FORM RB 1

**REPUBLIC OF KENYA
PUBLIC PROCUREMENT ADMINISTRATIVE REVIEW BOARD**

APPLICATION NO.....OF.....20.....

BETWEEN

.....APPLICANT

AND

.....RESPONDENT (Procuring Entity)

Request for review of the decision of the..... (Name of the Procuring Entity) of
.....dated the...day of20.....in the matter of Tender No.....of
.....20...

REQUEST FOR REVIEW

I/We.....,the above named Applicant(s), of address: Physical
address.....Fax No.....Tel. No.....Email, hereby request the Public
Procurement Administrative Review Board to review the whole/part of the above mentioned decision on
the following grounds , namely:-

- 1.
 - 2.
- etc.

By this memorandum, the Applicant requests the Board for an order/orders that: -

- 1.
 - 2.
- etc

SIGNED(Applicant)

Dated on.....day of/...20...

FOR OFFICIAL USE ONLY

Lodged with the Secretary Public Procurement Administrative Review Board on day of
.....20.....

SIGNED:

Board Secretary

SECTION 14: SPECIFICATIONS, DRAWINGS AND BILLS OF QUANTITIES

1.1 Location, Extent of Site and scope works.

The proposed improvement works is along the stated road project and length as given in the bill of quantities.

1.2 Extent of Contract:

The Major Works to be executed under the Contract comprise mainly of but are not limited to the following:

- Site Clearance
- Grading and bush clearing works

1.3 Change of scope in future:

In case of the change of conditions of the intended works in future. There shall be Change of the scope of works to reflect the true condition and situation as it is on the said project contract but should be within the required conditions and threshold of this tender document.

I. SPECIFICATIONS

Contents:

SECTION 01: PRELIMINARY AND GENERAL ITEMS..... E-1

01-40-001:	Mobilisation and Establishment of the Site.....	E-1
01-40-002:	Clearance on Completion.....	E-1
01-40-003:	Insurances and Securities.....	E-1
0140-004:	Quality Control Tests.....	E-2
01-40-005:	Publicity Sign Boards.....	E-2
01-40-006:	Traffic Control.....	E-2
01-40-007:	Drinking Water.....	E-3
SECTION 02	SETTING OUT.....	E-4
02-50-001	Setting Out Horizontal Alignment.....	E-4
SECTION 04	SITE CLEARANCE.....	E-5
04-50-002	Grass cutting.....	E-5
04-50-003	Bush Clearing (heavy).....	E-6
04-50-004	Bush Clearing (Light).....	E-6
04-50-005	Pruning Tree Branches	E-7
04-50-006	Trees and Stumps Removal.....	E-7
04-50-007	Trees and Stumps Removal (>450mm girth).....	E-7
04-50-009	Rock/Boulder Removal.....	E-8
04-50-010	Stripping and Grubbing.....	E-8
SECTION 05	EARTHWORKS.....	E-10
05-40-001:	Re-Establishment of the Vertical Alignment.....	E-10
05-50-007:	Excavation to Level.....	E-10
08-50-003:	Side-drain Excavation (Soft Material).....	E-11
08-50-004:	Side-drain Excavation (Hard Material).....	E-12
08-50-005:	Mitre Drains/Catchwater Drains.....	E-12
05-50-008:	Spreading and Compaction for Camber formation	E-13
SECTION 07:	EXCAVATION AND FILLING FOR STRUCTURES.....	E-14
07-50-002	Excavation for Drainage Structures.....	E-14
SECTION 08	CULVERT AND DRAINAGE WORKS.....	E-15
08-50-002:	Ditch Cleaning-manual.....	E-15
08-60-001/005:	Culvert cleaning - partially blocked.....	E-16
08-60-006/010:	Culvert cleaning - fully blocked.....	E-17
08-60-016/035:	Concrete Pipe Culverts.....	E-17
08-70-001	Headwall Repair - masonry	E-19
08-70-002:	Headwall Repair - concrete.....	E-19
08-70-003	Minor Drainage Structures - masonry.....	E-20
08-70-004	Minor Drainage Structures - concrete.....	E-20
08-70-005	Scour Checks – concrete.....	E-21
08-70-006	Scour Checks – masonry.....	E-21
08-70-007	Scour Checks - wooden stakes.....	E-21
08-70-016	Stone Pitching.....	E-23
08-80-002	Gabion Installation.....	E-24
08-80-003	Rockfill to Gabions.....	E-24
08-80-004	Drift Desilting.....	E-25
08-80-005	Drift Repairs - Concrete.....	E-25
08-80-006	Drifts - Stone Pitching.....	E-26
08-80-007	Drifts - Concrete.....	E-26
08-80-008	At-level Scour Checks.....	E-26
08-80-009	Stone Chute Stabilisation.....	E-27
08-80-010	Stone Post Chute Stabilisation.....	E-27
08-80-011	Stone Check Dams.....	E-28
08-80-012	Stone and Post Check Dams.....	E-28
SECTION 10	GRADING AND GRAVELLING.....	E-29
10-50-002:	Carriageway Grading - heavy.....	E-30
10-50-004:	Carriageway Grading - light.....	E-30
10-80-004:	Removal of Overburden - labour.....	E-31

10-80-009:	Removal of Overburden - equipment.....	E-31
10-80-005:	Haulage - Overhaul.....	E-31
10-80-007	Excavation; Free hand; Spreading and Compaction of Gravel-Labour.....	E-32
10-80-008	Excavation; Free Haul, Spreading and Compaction of Gravel-Equipment.....	E-34
10-80-010	Restoration of Quarries and Borrow Pits.....	E-34
SECTION 12	NATURAL MATERIAL BASES.....	E-35
12-50-001	Hand Packed Stone Pitching.....	E-35
SECTION 15	BITUMINOUS SURFACE TREATMENTS.....	E-36
15-70-008	Slurry Seal.....	E-38
15-70-010	Surface Dressing – Single.....	E-39
15-70-011	Surface Dressing – Double.....	E-39
15-70-012	Cold Asphalt.....	E-40
15-70-013	Otta Seal – Single.....	E-40
15-70-014	Otta Seal – Double.....	E-40
SECTION 17	CONCRETE WORKS.....	E-42
17-40-001	Concrete Road Section.....	E-42
SECTION 20	ROAD FURNITURE.....	E-43
20-50-001:	Traffic Sign Maintenance.....	E-43
20-50-002	Erection of Traffic Signs.....	E-43
20-50-004	Marker Post Replacement.....	E-44
20-70-001	Guardrail Repair.....	E-44
20-70-003	Erection of Guardrails.....	E-45
SECTION 22	DAYWORKS.....	E-46
22- Activity Codes		
SECTION 25:	HIV/AIDS AWARENESS AND PREVENTION CAMPAIGN.....	E-47
25-50-001	HIV/AIDS Awareness Campaign.....	E-47
25-50-002	HIV/AIDS Prevention Campaign.....	E-47
25-50-003	HIV/AIDS and Cross-cutting Issues.....	E-47

SECTION 01 : PRELIMINARY AND GENERAL ITEMS

Scope:

This section comprises those items that are required at the Commencement and Completion of the Works or that are Provisional Items applicable for the duration of the Works.

01-40- 001 Mobilisation and Establishment of the Site

The Contractor shall provide all equipment, tools, materials, temporary offices, stores and housing required to carry out the Works.

The Contractor shall ensure that all possible means of protection are given to the labour force at all times. Such protection shall include provision of high visibility clothing or vests, goggles and masks for workers in potentially dangerous locations or dealing with potentially harmful materials. The Contractor shall also maintain first aid kits with a minimum of the following items:-

- Non Stick wound dressing
- Selection of plaster/band aids
- Crepe bandages
- Gauze and cotton wool
- Antiseptic solution (washing wounds)
- Antiseptic cream – Betadine, Burnol
- Pain killers Panadol, Disprin
- Anti diarrhoea – Immodium, Diadis, Charcoal
- Anti histamine – Piriton, Triludan
- Anti nausea – Stemetil
- Eye ointment
- Oral re-hydration sachets
- Surgical gloves

Measurement and Payment:

No separate payment shall be made for this item. The Contractor shall include the costs in the rates for other measured items.

01-40- 002 Clearance on Completion

On Completion of the Works, all temporary housing, equipment, signs and tools shall be removed from the site, and the site left in good order to the satisfaction of the Engineer.

Measurement and Payment

The Lump Sum payment will be made upon approval by the Engineer that the Clearance has been satisfactorily carried out.

01- 40-003: Insurance and Bonds

The Contractor shall provide Insurance and Sureties in accordance with relevant Clauses in the Conditions of Contract.

Measurement and Payment

Lump Sum payment for this item will be made upon the production of satisfactory evidence by the Contractor that Insurances and Securities have been affected.

01-40-004: Quality Control Tests

The Engineer may instruct the Contractor during the progress of the Works to carry out quality control tests to check materials and standards of workmanship, against the Specifications.

Where such tests indicate defective standards the Engineer shall instruct the Contractor to rectify the defects to the

Engineer's satisfaction and at the Contractor's expense.

Measurement and Payment

The Engineer shall include a Provisional Sum for this item to be expended only as and when the Contractor is instructed to carry out tests.

01-40-005 Publicity Sign Boards

The Contractor shall provide Sign Boards as specified on the Drawings or as directed by the Engineer. The Sign Boards shall be placed at the beginning and end of the road or road section covered by this Contract.

Sign Boards shall be maintained for the duration of the Works, and removed on completion.

Quality Control

The Engineer shall check that Sign Boards have been erected in accordance with Drawings and Specifications.

Measurement: Number

The unit of measurement shall be number of Sign Boards erected

Payment

The unit rate shall be the full compensation for labour, tools, materials and incidental costs required for carrying out the work.

01-40- 006 Traffic Control

The Contractor shall provide warning signs, fences, barriers, detours, which shall be properly positioned in advance of the Works to ensure that traffic is well and safely accommodated for the duration of the Works.

Traffic signs and other traffic control facilities shall be kept in good condition and located in positions where they are visible to road users.

Quality Control

The Engineer shall check regularly that traffic control measures are satisfactory.

Measurement and Payment

A Lump Sum shall be paid on a Monthly basis upon the approval of the Engineer that satisfactory control measures are in place.

01-40- 007: Drinking Water

The Contractor shall provide safe drinking water on site for workers at a reasonable distance from all work locations, for the duration of the Works.

Quality Control

The Engineer shall check regularly that adequate supplies of water are available throughout the Site.

Measurement and Payment

A Lump Sum shall be paid on a Monthly basis upon the approval of the Engineer that adequate supplies have been provided.

SECTION 5: EARTHWORKS

Scope

This section covers the excavation of soil and the placing, watering and compaction of hard and soft material to form the road formation.

05-40- 001: Re - Establishment of the Vertical Alignment

The Contractor shall re-establish the vertical alignment of the road section which includes the setting out excavation of horizontal slots marking the level road platform.

The width of the slots shall be 0.5 m and they shall be set out at 10m intervals along the straight section and 5m on the curve sections of the road. Each slot shall be compacted using hand rammers until no more imprints of the rammer on the surface of the slot can be seen. The length of each slot shall be equal to the formation width of the road.

Vertical alignment standards shall be those set out in Table 5.1

Table 5.1 Vertical Alignment Standards

Standard	Flat & Rolling Terrain	Hilly Terrain
Gradients		
Desirable Minimum	2%	2%
Desirable Maximum	8%	10%
Absolute Maximum	10%	12%

Work method

The Contractor shall apply **Labour** methods to carry out this item work.

Quality Control:

The hand rammer shall be not less than 5kg

The level of the slot shall have a tolerance of ± 50 mm

The longitudinal profile of the road shall be checked at every third slot and shall have a maximum tolerance of ± 50 mm

Measurement Unit: M3

The measurement shall be linear metres of road alignment set out

Payment:

The unit rate shall be the full compensation for labour, tools, materials and incidental costs required for carrying out the work.

05-50- 007 Excavation to Level and Compaction

The Contractor shall cut material to form the level road platform and place the excavated material as fill or in spoil areas approved by the Engineer. Where material needs to be borrowed excavation shall only be from borrow areas approved by the Engineer.

The fill layers to be compacted shall not exceed 150mm loose depth.

Compaction of the fill material shall be carried out from the edges to the centre by overlapping passes of the compaction equipment. The number of passes shall be as directed by the Engineer dependent upon the equipment used and the material being compacted. Unless otherwise instructed the moisture content of the material shall be within $\pm 2\%$ of optimum. Where additional moisture is required water shall be applied in an even manner such that no longitudinal or transverse flow occurs.

The Engineer may instruct the Contractor to carry out density tests on the compacted material to ensure that an acceptable standard has been achieved.

Work Method

The Contractor shall use **Labour** and appropriate compaction **Equipment** to carry out this item of work.

Quality Control

The width of the platform shall be checked at intervals of 50 m and shall have a tolerance of $+ / - 50\text{mm}$.

The level platform shall be horizontal in the transverse direction and shall have a tolerance of $+ / - 15\text{ mm}$ under a 2 metre straight edge.

The longitudinal profile shall have a maximum tolerance of $+ / - 50\text{ mm}$ over a 30m length of gradient.

Compaction shall show no movement of material under the roller.

Compaction test standard shall be 95% MDD (AASHTO T99)

Measurement Unit: M³

The measurement shall be the volume of compacted fill material forming the level platform.

Payment:

The unit rate shall be the full compensation for labour, tools, equipment, water and incidental costs required for carrying out the work.

08-50-003: Side-drain Excavation (Soft Material)

The Contractor shall excavate side drains to the profiles shown on the Drawings or as directed by the Engineer.

The material from the excavations shall be used for the formation of the camber. Where additional material is required to achieve the required camber, the widths of the side drains may be increased, with the approval of the Engineer.

Locations of the side drains shall be as shown on the Drawings or as directed by the Engineer, and the Contractor shall use the appropriate ditch template to control the excavations

Work method:

The Contractor shall apply **Labour** methods to carry out this item

Quality Control:

The dimensions of the side drains shall be checked at 50m intervals and shall have a tolerance of $\pm 50\text{mm}$

The longitudinal profile of the side drains shall be checked at 30m intervals and shall have a tolerance of $+/-50\text{mm}$.

Measurement Unit: M³

Measurement shall be the volume of material excavated to form the side drains, and deposited for camber formation.

Payment:

The unit rate shall be the full compensation for labour, tools and incidental costs required for carrying out the work.

08-50-004 Side-drain Excavation (Hard material)

Where, in the opinion of the Engineer, the material to be excavated to form the side drains may be classified as hard the Contractor shall carry out the excavation in accordance with 05-003 and shall be compensated under this item,

Work Method:

The Contractor shall apply **Labour** methods with appropriate **Equipment** to carry out this item.

Quality Control:

The Engineer shall measure the volume of the excavation classified as hard material

Measurement Unit: M³

The measurement shall be the volume of material excavated and deposited to form the camber

Payment:

The unit rate shall be the full compensation for all labour, tools, equipment and incidental costs required to complete the work.

08-50- 005 Mitre Drains/Catch water Drains

- i. Labour.**
- ii. Equipment.**

The Contractor shall excavate mitre drains and catch water drains to the dimensions shown on the Drawings and at locations as directed by the Engineer. They shall be excavated in a manner to minimise erosion at the discharge point. The material excavated from the drains shall be used to form the side drain bund directing water to the mitre-drain, and a bund on the lower side of the cut-off drain, or disposed of as directed by the Engineer.

Work Method

The Contractor shall use either **Labour** or **Equipment** as directed by the Engineer to carry out this work.

Quality Control

The longitudinal profile shall have a gradient of maximum 4%.

The dimensions of the mitre drains shall have maximum tolerances of ± 20 mm

The location of the mitre drains shall be approved by the Engineer.

Measurement Unit: M³

The measurement shall be the volume of material excavated as measured on site in approved drains.

Payment

The unit rate shall be full compensation for labour, tools, equipment and incidental costs required for carrying out the work.

05-50- 008 : Spreading and Compaction for Camber Formation

The Contractor shall spread and compact the material deposited from the side drains to form the camber on the road, in accordance with the Drawings or as directed by the Engineer, and shall check the profile with the appropriate camber board.

Compaction shall be carried out from the edges to the centre line by overlapping passes of the compaction equipment. The number of passes shall be as directed by the Engineer dependent upon the equipment used and the material being compacted. Unless otherwise instructed the moisture content of the material shall be within $\pm 2\%$ of optimum. Where additional moisture is required water shall be applied in an even manner such that no longitudinal or transverse flow occurs.

The Engineer may instruct the Contractor to carry out density tests on the compacted material to ensure that an acceptable standard has been achieved.

Work method:

The Contractor shall use **Labour** and appropriate compaction **Equipment** to carry out this item.

Quality Control:

The width of the carriageway including the shoulders shall be checked at 50m intervals and shall have a tolerance of +50/-20 mm.

The camber shall be checked 50m intervals and shall have a tolerance of +/- 1%.

Compaction shall show no movement of material under the roller

Compaction test standard shall be 98% MDD (AASHTO T99)

Measurement Unit: M³

The measurement shall be the area of camber formed, according to the specified carriageway width and measured length of road.

Payment:

The unit rate shall be the full compensation for all labour, tools, equipment, water and incidental costs required for carrying out the work.

SECTION 08: CULVERT AND DRAINAGE WORKS**Scope**

This section covers all Works in connection with the installation of concrete pipe culverts; inlet and outlet structures; drifts and drainage protection Works; and the construction of Scour Checks

08- 50-002: Ditch Cleaning (Manual)**Partially silted**

Partially silted drains are those that are less than half silted and require only cleaning.

All deposited material, debris, and vegetation shall be removed and the drain shaped to the original cross-section and left in a free-draining condition. Suitable material may be used to fill depressions and potholes on the carriageway. All debris and other unsuitable material removed from the side drains shall be disposed of well clear of the drainage system in approved spoil dumps where it will not cause any obstruction or be washed back.

The side drains, mitre drains and catchwater drains shall be cleaned before the onset of the rains or as directed by the Engineer.

Work Method

The Contractor shall use **Labour** to carry out this item of work

Quality Control

Appropriate drain templates shall be used to check and control the dimensions of the drains.

The longitudinal profile of the drains shall be checked using boning rods, to ensure free flow.

Measurement Unit: M3

The measurement shall be the length of drain desilted or cleaned to the specified cross-section.

Payment

The unit rate shall be full compensation, for labour, tools, and incidental costs required to carry out the work.

Fully silted

Fully silted drains shall be those that are greater than half-silted and require re-excavation or reshaping.

All deposited material, debris, and vegetation shall be removed and the drain shaped to the original cross-section

and left in a free-draining condition. Suitable material may be used to fill depressions and potholes on the carriageway. All debris and other unsuitable material removed from the side drains shall be disposed of well clear of the drainage system in approved spoil dumps where it will not cause any obstruction or be washed back.

The side drains shall be desilted or re-excavated before the onset of the rains, or as directed by the Engineer.

Work Method

The Contractor shall use **Labour** to carry out this item of work

Quality Control

Appropriate drain templates shall be used to check and control the dimensions of the drains. The longitudinal profile of the drains shall be checked using boning rods, to ensure free flow.

Measurement Unit: M3

The measurement shall be the length of drain re-excavated or re-shaped to the specified cross-section.

Payment

The unit rate shall be full compensation for labour, tools, and any incidental costs required to carry out the work.

08-60-001/005: Culvert Cleaning (partially blocked)

08-60-001	300mm dia
08-60-002	450mm dia
08-60-003	600mm dia
08-60-004	900mm dia
08-60-005	1200 mm dia

This activity involves the cleaning of culverts of specified sizes including pipe barrels, the outlet/inlet structures, and the outlet drains, keeping them free of all debris, weed, silt and any obstruction to ensure free passage of water at all times. The debris shall be deposited in approved spoil dumps as directed by the Engineer

Partially blocked culverts shall be those with less than half of the barrel blocked.

Correct widths and slopes of the outlet drains shall be maintained. The gradient of the outlet drain shall be not less than 2 %.

All broken culvert barrels discovered in the course carrying out this activity shall be reported to the Engineer.

This activity shall be carried out before the rains, or as directed by the Engineer.

Work Method

The Contractor shall use **Labour** to carry out this item of work

Quality Control

The culverts shall be checked as free of debris to the satisfaction of the Engineer.

Measurement Unit: M3

The measurement shall be the length of culvert, including the outlet drain, cleaned

Payment

The unit rate shall be full compensation for labour, tools and incidental costs required to carry out the work.

08- 60 - 006/7/8/9/10 : Culvert Cleaning (Fully blocked):

08 - 60 - 006 300mm dia;
 08 - 60 - 007 450mm dia;
 08 - 60 - 008 600mm dia;
 08 - 60 - 009 900mm dia;
 08 - 60 - 010 1200mm dia

This activity involves the cleaning of culverts of specified sizes including pipe barrels, the outlet/inlet structures, and the outlet drains, keeping them free of all debris, weed, silt and any obstruction to ensure free passage of water at all times. The debris shall be deposited in approved spoil dumps as directed by the Engineer

Fully blocked culvert shall be those with greater than half of the barrel blocked.

Correct widths and slopes of the outlet drains shall be maintained. The gradient of the outlet drain shall be not less than 2 %.

All broken culvert barrels discovered in the course of carrying out this activity shall be reported to the Engineer.

This activity should be carried out before the onset of the rains, or as directed by the Engineer.

Work Method

The Contractor shall use **Labour** to carry out this item of work.

Quality Control

The culverts shall be checked as free from debris, to the satisfaction of the Engineer.

Measurement Unit: M3

The measurement shall be the length of culvert, including the outlet drain cleaned.

Payment

The unit rate shall be full compensation for labour, tools and incidental costs required to carry out the work.

08-60-016/035		Concrete Pipe Culverts		
08-60-016	300 mm	haunched	(Type II)	
08-60-017	300 mm	unhaunched	(Type I)	
08-60-018	450 mm	haunched	(Type II)	
08-60-019	450 mm	unhaunched	(Type I)	
08-60-020	600 mm	haunched	(Type II)	
08-60-021	600 mm	unhaunched	(Type I)	
08-60-022	900 mm	haunched	(Type II)	
08-60-023	900 mm	unhaunched	(Type I)	
08-60-024	1200 mm	haunched	(Type II)	
08-60-025	1200 mm	unhaunched	(Type I)	
08-60-026	300 mm	semi-surround	(Type III)	
08-60-027	300 mm	surround	(Type IV)	
08-60-028	450 mm	semi-surround	(Type III)	
08-60-029	450 mm	surround	(Type IV)	
08-60-030	600 mm	semi-surround	(Type III)	
08-60-031	600 mm	surround	(Type IV)	
08-60-032	900 mm	semi-surround	(Type III)	
08-60-033	900 mm	surround	(Type IV)	
08-60-034	1200 mm	semi-surround	(Type III)	
08-60-035	1200 mm	surround	(Type IV)	

The Contractor shall supply, lay and joint concrete pipes to form culverts, including the concrete bedding;

haunching or surrounds; and backfilling, in accordance with the Drawings for the Type and diameter specified in the Contract or directed by the Engineer.

The pipes shall be of Class 20/20 concrete, at least 28 days cured, and manufactured on site or procured from a supplier approved by the Engineer. The pipes shall be laid on a bedding of Class 15/20 concrete of dimensions as shown on the Drawings and jointed with cement mortar 1:4.

The culvert gradient including the outlet shall be a minimum 2%.

The pipes shall be haunched or surrounded, according to the Type specified, with Class 15/20 concrete to the dimensions shown on the Drawings or as directed by the Engineer.

Backfilling shall be carried with approved material and compacted in layers not exceeding 150 mm loose depth and placed evenly on each side of the pipe. Ramps shall be shaped to achieve a minimum overfill of 75% of the pipe diameter, and shall be tapered back on the carriageway to provide a gradual approach, as directed by the Engineer.

If the Contractor wishes to construct culverts in-site, using inflatable or collapsible forms the Engineer's approval shall first be sought for the proposed working method.

On completion the inside of the culvert shall be smooth, without displaced joints or other obstructions and true to line and level.

Work Method:

The Contractor shall use **Labour** and appropriate **Equipment** to carry out this item work

Quality Control

Concrete quality shall be checked for cracks, honey combing, and other defects.

Before the pipes are laid, the gradient of the concrete bedding shall be checked and shall not be less than 2%

The joints shall be checked to see that they have been properly made.

Measurement Unit: M3

The measurement shall be in linear metres of the installed Type and size of culvert specified, measured net according to the Drawings.

Payment

The unit rate shall be the full compensation for labour, tools, materials, equipment and any other incidentals that may be required in carrying out the work.

08- 70- 001 Head Wall Repair - Masonry

This activity involves the repairs to damaged head walls and wing walls built in masonry.

Where directed by the Engineer, the masonry walls shall be inspected and loose or missing stone re-secured or replaced. Damaged pointing shall be repaired with cement mortar 1:4 and finished flush with the stonework.

Work Method

The Contractor shall use **Labour** to carry out this item of work

Quality Control

The stability of the walls and the pointing shall be to the satisfaction of the Engineer.

Measurement Unit: M3

The measurement shall be the number of walls repaired as directed by the Engineer.

Payment:

The unit rate shall be full compensation for labour, materials, tools, and incidental costs required to carry out the work.

08-70-002: Headwall Repair - Concrete

The activity involves the repairs to damaged concrete headwalls and wing walls, and to inlet/outlet concrete aprons. Concrete walls shall be inspected and repair works carried out as instructed by the Engineer to include breaking out and replacement of damaged concrete with similar material, and the rendering of open texture areas with cement mortar 1:4. Broken wall sections shall be re-built in 20/20 (1:2:4) concrete within formwork erected on the correct lines and levels in accordance with the Standard Drawings. Areas of new concrete and mortar shall be protected from direct sunlight and kept moist for 3 days.

Quality Control

The work shall be carried out to the satisfaction of the Engineer.

Measurement Unit: M3

The measurement shall be the number of walls/aprons repaired.

Payment

The unit shall be full compensation for labour, materials, tools, and incidental costs required to carry out the work.

Minor Drainage Structures - Masonry

08-70-003 Type I

08-70-016 Type 2

08-70-017 Type 3(a)

08-70-018 Type 3(b)

08-70-019 Type 4

The Contractor shall construct inlet and outlet structures for culverts including headwalls, wingwalls in stone masonry or concrete block, and aprons in concrete to the dimensions and levels shown on the Drawings or as directed by the Engineer. The walls shall be built on foundations of class 15/20 concrete and jointed with cement mortar 1:4. The aprons shall be in Class 20/20 concrete and after laying the surface shall be kept moist for 3 days.

Work Method

The Contractor shall use **Labour** to carry out this item.

Quality Control

The dimensions of the structures shall have a tolerance of + / - 10mm

The levels shall have a tolerance of + / - 10mm

The mortar joints shall be finished flush with the face of the walls.

Measurement Unit: M3

The measurement shall be the volume of the structures constructed, in whichever material, measured net according to the Drawings.

Payment

The unit rate shall be the full compensation for labour, tools, materials and any other incidentals that may be required in carrying out the work.

Minor Drainage Structures – Concrete

08-70-004 Type I

08-70-021 Type 3(a)

08-70-022 Type 3(b)

08-70-023 Type 4

The Contractor shall construct inlet and outlet structures for culverts in concrete to the dimensions and levels shown on the Drawings or as directed by the Engineer.

Concrete shall be Class 20/20 unless otherwise specified. The formwork for the walls shall be erected on the concrete foundations, to the correct dimensions, and shall be approved by the Engineer before concrete is poured. Concrete shall be poured in a single lift and the top surface shall be kept moist for 3 days. Formwork may be struck after 2 days or as directed by the Engineer.

The Contractor shall use a concrete vibrator or other means approved by the Engineer to ensure full compaction of the concrete.

Work Method

The Contractor shall use both **Labour** and appropriate **Equipment** to carry out this item.

Quality Control

The dimensions of the structures shall have a maximum tolerance of + 20mm / - 10mm

The workability and mix of concrete shall be checked using the slump test and shall have a slump limit as directed by the Engineer. The frequency of testing shall be determined by the Engineer

The concrete shall be checked for cracks, honey combing and other defects at the time of striking the formwork.

Measurement Unit: M3

The measurement shall be the volume of concrete in the completed structure, measured net in accordance with the Drawings.

Payment

The unit rate shall be the full compensation for labour, tools, materials, formwork, equipment and other incidentals that may be required in carrying out the work.

08-70-005 Scour Checks (Concrete)

08-70-006 Scour Checks (Masonry)

08-70-007 Scour Checks (Wooden Stakes)

The Contractor shall construct scour checks using either stones, stakes, or concrete as instructed by the Engineer.

Construction of concrete scour checks shall be in class 20/20 concrete, unless otherwise specified, and to the details shown in the Drawings.

Spacing for scour checks shall be as shown in Table 8.1, or as directed by the Engineer.

Table 8.1 : Scour checks spacing:

Gradient of Drain	Scour Check Spacing	Gradient of Drain	Scour Check Spacing
4% or less	not required	8%	7.5m
5%	20m	9%	6m
6%	15m	10%	5m
7%	10m	>10%	4m

Work method

The Contractor shall use **Labour** to carry out this item.

Quality Control

The spacing of the scour checks shall have a tolerance of $\pm 0.5\text{m}$

The sizes of the stakes and stones used shall be in accordance with the Drawings

The shape of the scour check shall be checked using the scour check template.

Measurement Unit: **No.**

The measurement shall be the **number** of scour checks constructed.

Payment

The unit rate shall be full compensation, for labour, tools, materials and incidental costs required for carrying out the work.

08 – 70 – 008: **Scour Check Repair - masonry**

08 – 70 – 009: **Scour Check Repair - wooden**

08 - 70 - 010: **Scour Check Repair - concrete**

This activity involves the repair of Scour Checks using stones or wooden stakes or concrete. The construction details shall be shown in the Drawings or as instructed by the Engineer.

Scour checks shall be inspected and the repairs carried out as directed by the Engineer, which shall include replacement of missing or broken stonework and stakes; and the repair of damaged concrete, to the original lines, levels, and Specifications.

Work Method

The Contractor shall use **Labour** to carry out this item work.

Quality Control

The sizes of the stakes and stones used shall be as the original construction.

The shape of the scour check shall be checked using the scour check template.

Measurement: No.

The unit rate of measurement shall be the number of scour checks repaired.

Payment

The unit rate shall be full compensation, for labour, tools, materials, and incidental costs required for carrying out the work.

08- 70- 011 : **Stone Pitching Repair**

This activity involves the repair of stone pitching on slopes, in inlet/outlet aprons and access drifts. The stone pitching shall be inspected and repairs carried out as directed by the Engineer, including the replacement and re-bedding of missing or loose stones; the repair of mortar jointing; and the cleaning out of weepholes, as required. All work shall be to the lines and levels of the original construction with new stonework and mortar being flush with the adjacent materials.

Work Method

The Contractor shall use **Labour** to carry out this work

Quality Control

The work shall be carried out to the satisfaction of the Engineer.

Measurement Unit: M3

The measurement shall be the net surface area of the repairs.

Payment:

The unit rate shall be full compensation, for labour, tools, materials, and incidental costs required to carry out the work.

08-70- 016: Stone Pitching

The Contractor shall lay stone pitching at locations shown on the Drawings or as directed by the Engineer, which shall include levelling the area to be covered with stone pitching, collecting stones, laying stones, applying mortar to the joints and constructing weep holes, if required.

The area to be covered with stone pitching shall be trimmed to the level and slope shown on the Drawings or as directed by the Engineer. The prepared surface shall be firm and well compacted, with hand rammers.

The stones shall have minimum dimensions of 150mm and maximum 300mm and shall be set on the flat side and securely bedded, with the largest dimensions at right angles to the flow of water, in an interlocking pattern so as to leave only a minimum of voids between the stones which shall be filled with suitably shaped and tightly wedged spalls. The top of the pitching shall be finished flush with the adjacent material.

The stones shall be placed in full contact with the surface and bedded into cement mortar 1:4 with a minimum thickness of 100 mm. The mortar shall be worked into the pitching so that the voids between the stones are filled to the full depth of the pitching. The mortar shall be finished flush with the surface of the stones.

Weep holes shall be provided to stone pitching on slopes as directed by the Engineer.

The surface of the stone pitching shall be protected from direct sunshine and kept moist for 2 days.

Work Method:

The Contractor use **Labour** to carry out this item.

Quality Control:

The quality of pitching shall be checked for gaps and voids.

The dimensions of the area of stone pitching shall have a tolerance of + / - 100mm

Measurement Unit: M3

The measurement shall be the total area of pitching calculated as the net area, measured on the slope.

Payment:

The unit rate shall be full compensation, for labour, tools, materials, and incidental costs required for carrying out the work.

08-80- 002: Gabions

The Contractor shall provide and install Gabions as retaining walls and anti-erosion structures at locations shown on the Drawings or as directed by the Engineer.

Gabions shall include mattresses and boxes and for purposes of construction, measurement and payment, no distinction shall be made between them.

Gabions shall be 'Maccaferi' boxes or 'Reno' mattresses or equivalent approved by the Engineer.

The surfaces on which the Gabions are to be laid prior to being filled with rock shall be levelled to the depths and dimensions shown on the Drawings or as directed by the Engineer.

Gabion boxes shall be tied together with 3 mm galvanised binding wire securing all edges at 150mm intervals.

Work Method:

The Contractor shall use **Labour** to carry out this item.

Quality Control:

The placing and tying of the Gabions shall be approved by the Engineer before filling commences.

Measurement Unit: No

The measurement shall be the number of Gabion boxes installed.

Payment:

The unit rate shall be the full compensation for labour, materials, and any incidental item costs necessary to carry out the work.

08-80-003: Rock fill to Gabions

The Contractor shall provide selected rock, crushed if necessary, and carry out the packing and compacting of the rock inside the Gabion boxes.

The boxes shall be filled in layers from the sides towards the middle in an interlocking stone matrix to prevent deformation and bulging. The interior and top layers of the boxes shall be hand packed with smaller stone to form a tightly compact structure and rammed in place. Care shall be taken to ensure that each layer of boxes is filled evenly and to a level surface before the next course of boxes is placed.

Work method:

The Contractor shall use **Labour** to carry out this activity.

Quality Control

The filling and compaction of the stones in the Gabion boxes shall be approved by the Engineer.

Measurement Unit M³

Rock fill to Gabions shall be the volume of Gabions filled.

Payment:

The unit rate shall be the full compensation for labour, tools, materials and incidental costs required for carrying out the work.

08- 80- 004 Drift Maintenance – desilting

This activity involves the removal of debris, silt and any vegetation from drifts and causeways. The debris shall be deposited away from the drift in approved spoil dumps.

This activity shall be carried before the rains, or as directed by the Engineer.

Work Method:

The Contractor shall use **Labour** to carry out this item of work

Quality Control:

The work shall be carried out to the satisfaction of the Engineer.

Measurement Unit: M³

The measurement shall be the volume of debris or silt removed calculated as the product of length , width and measured depth of the affected section of drift.

Payment

The unit rate shall be full compensation for labour, tools, and incidental costs required to carry out the work.

08-80-005 Drift Repairs – Concrete

This activity involves the repair of concrete drifts, including the removal of loose or broken concrete, cutting back damaged areas to sound surfaces and repairing with concrete of similar Class to the original.

The drift shall be inspected and necessary repairs shall be instructed by the Engineer. Holes and voids shall be cleared of debris, loose material and dust, and shall be well watered before the new concrete is placed. The new concrete shall be firmly rammed against the existing surfaces and finished flush with the surrounding materials. The surface of the repair shall be protected from direct sunlight and kept moist for 3 days. Concrete shall be Class 20/20 unless otherwise directed by the Engineer.

Quality Control

The work shall be carried out to the satisfaction of the Engineer.

Measurement Unit: m³

The measurement shall be the volume of concrete used for the repair.

Payment:

The unit rate shall be the full compensation for labour, tools, materials and incidental costs required to carry out the work.

08- 80-006 Drifts (Stone Pitching)

08-80-007 Drifts (Concrete)

The Contractor shall construct Access drifts in grouted stone pitching and watercourse drifts in concrete at locations, and to the dimensions, shown on the Drawings or as directed by the Engineer. This shall include the provision of stone and the levelling of the areas to be covered.

The stone pitching for Access drifts shall comply with the requirement of 08–70-016 with the addition of masonry toes at each end of the drift as shown on the Drawings.

Concrete drifts shall be constructed in Class 20/20 concrete to the lines and dimensions shown on the Drawings or as directed by the Engineer.

The area to be covered shall be trimmed to the line and slope shown on the Drawings or as directed by the Engineer, and the prepared surface compacted with hand rammers or appropriate equipment. The concrete shall be poured in bays of half road width and of length 10-15 metres, between construction joints, with steel mesh reinforcement mats laid 50mm below the finished surface level. Contraction joints if required shall correspond with the construction joints where directed by the Engineer expansion joints shall be installed at positions and to the details given by the Engineer.

The grouted stone pitching and the concrete shall be covered with wet sacking or other approved cover for not less than 4 days after laying and shall not be subject to loading until adequate strength has been developed as instructed by the Engineer.

Work Method

The Contractor shall use **Labour** and appropriate **Equipment** to carry out this item.

Quality Control

- i) Stone pitching quality shall be as for 08-70-016
- ii) Concrete shall be checked by slump test to the standard as directed by the Engineer.

Measurement Unit: M³

The measurement shall be the volume of stone pitching or concrete laid, measured net according to the Drawings.

Payment

The unit rate shall be full compensation for labour, tools, materials, equipment and incidental costs required for carrying out the work.

08-80-008 At-level Scour Checks

The Contractor shall select and place flat stones of minimum dimensions 0.10-0.15m in gently sloping channels. The stones shall be placed in a manner to ensure minimum voids within the structure. A trench 0.2m deep by 0.2m wide shall be excavated in the invert of the channel and extended 0.2m into the slopes. Stones shall be laid up to the level of the invert with the middle section lower than the sides to form a spill way. The spacing of the checks shall be 1-4 metres, as directed by the Engineer.

Work Method

The Contractor shall use **Labour** to carry out this item.

Quality Control

The construction and spacing of the scour checks shall be checked by the Engineer.

Measurement Unit: No

The measurement shall be the number of scour checks constructed.

Payment

The unit rate shall be full compensation for labour, tools, materials and incidental costs required to carry out the work.

08-80-009/010 Gully-head Protection

08-80-009 Stone Chute Stabilisation

08-80-010 Stone and Post Chute Stabilisation

The Contractor shall construct gully-head protection works as directed by the Engineer to the dimensions and details shown on the Drawings.

The dimensions of the stones shall not be less than 200mm and the volume not less than 0.01m³ for the smaller stones and pebbles to be used as the transition layer between the stone structure and the ground. No rounded stones shall be used. Posts shall be durable hardwood minimum 900mm in length and 15mm diameter.

The gully head shall be excavated as shown on the Drawings to form a firm base for the stone layers. The initial layer shall be the small stones and gravel to a depth of 150mm after which the larger stone shall be carefully placed to form a compact matrix. Posts shall be driven a minimum of 600mm into the ground at spacing as directed by the Engineer.

Work Method

The Contractor shall use **Labour** to carry out this item

Quality Control

The stone dimensions and construction shall be checked by the Engineer.

Measurement Unit: No

The measurement shall be number of units constructed.

Payment:

The unit rate shall be full compensation for labour, tools, materials and incidental costs required to carry out the

work.

08-80-011/012 Check Dams

08-80-011 Stone Dams

08-80-012 Stone and Post Dams

The Contractor shall construct check dams in erosion gullies to the dimensions and details shown on the Drawings and as directed by the Engineer.

The dimensions of the stones in the main structure shall not be less than 200mm and the volume not less than 0.01 m³ for the stones and pebbles for the transition layer between the stone structure and the ground. No rounded stones shall be used.

Posts shall be durable treated hardwood of minimum diameter 0.10m, of minimum length 1.6m, driven at least 600mm into the ground. Stones shall be carefully hand-packed to provide a stable structure with a minimum of voids.

The spacing of the check dams shall be as shown in the table below:

Check Dam Spacing					
Gradient	Height of dam spill way (m)				
	0.15	0.25	0.50	0.75	1.00
5	15.0	25.0			
7	5.0	8.7	17.5	25	35
10	2.5	4.2	8.4	12.6	16.8
15	1.4	2.3	4.6	6.9	9.2
20	0.9	1.6	3.2	4.8	6.4
25		1.3	2.5	3.8	5.0
30		1.0	2.0	3.0	4.0
40			1.6	2.4	3.2
50			1.2	1.8	2.0

Work Method

The Contractor shall use **Labour** to carry out this item

Quality Control

The Engineer shall check the workmanship and spacing of the check dams.

Measurement Unit: No

The measurement shall be the number of check dams constructed

Payment

The unit rate shall be full compensation for labour, tools, materials and incidental costs required to carry out the work.

SECTION 10: GRADING AND GRAVELLING

Scope:

Grading covers the work of the reinstating of the road carriageway to the correct camber by removing the high points and filling gullies, corrugations, and wheel ruts to restore a smooth running surface. Graveling consists of the excavation, loading, hauling, dumping and spreading of gravel wearing course material on the formation of the road carriageway. Gravel shall include lateritic gravel, quartzite gravel, calcareous gravel, decomposed rock, soft stone coral rag, clayey sand and crushed rock.

The material may be obtained from quarries, borrow pits or excavation in cuttings as directed by the Engineer. Gravel material shall conform to the requirement given in Table 10.1

Table 10.1: Requirement for Gravel Wearing Course:

GRADING REQUIREMENTS	
Sieve (mm)	% by Weight Passing
40	100
28	95 - 100
20	85 - 100
14	65 - 100
10	55 - 100
5	35 - 92
2	23 - 77
1	18 - 62
0.425	14 - 50
0.075	10 - 40

For “Quarry Waste” gravel stones of maximum dimension 80mm may be permitted

PLASTICITY INDEX REQUIREMENTS PI		
Zone	Min	Max
WET: Mean annual rainfall > 500mm	5	20
DRY: Mean annual rainfall < 500mm	10	30

BEARING STRENGTH REQUIREMENTS		
Traffic Commercial VPD	CBR	DCP Equivalent mm/Blow
>15	20	11
<15	15	14
CBR at 95 % MDD, Modified AASHTO and 4 days soaking		
Lower quality material (CBR 15) may be accepted if no better material can be found		

The Engineer shall approve quarries and the extent of their exploitation. The quarries shall be shown to the Contractor prior to commencement of the Works. The Contractor shall be responsible for the acquisition of the quarry rights and shall conduct respective negotiations with landowners and affected communities.

Alternative sources of gravel material whose quality can be shown to be in compliance with the specification requirements may be used, with the approval of the Engineer and at no extra cost to the Employer. The Contractor is deemed to have included in his rates for the provision of the gravel material.

10-50-002 Carriageway Grading – Heavy Grading

The Contractor shall scarify the existing carriageway surface, cutting high spots and moving materials to fill potholes, corrugations and wheel ruts and reshape the surface to the specified camber, using a Motor grader unless otherwise directed by the Engineer. All loose rocks, roots and grasses shall be removed and disposed of well clear of the drains.

Pegs 300 to 400mm long shall be placed at 20 m intervals to mark edge of the carriageway.

The material shall be bladed toward the centre of the road starting from both edges until the specified camber is achieved. Suitable material from the side drains may be used as additional material. Any further material needed to achieve the correct camber shall be from an approved source. Compaction shall be carried out using appropriate equipment approved by the Engineer, from the carriageway edges to the centerline in overlapping passes.

by the Engineer.

Work Method:

The Contractor shall use **Labour** and appropriate **Equipment** to carry out this item..

Quality Control

The location and manner of stock piling of the overburden for the reinstatement of the quarry shall be to the approval of the Engineer.

Measurement Unit: m³

The measurement shall be the volume of overburden removed as calculated from the cleared area and the mean depth indicated from the trial pits.

Payment

The unit rate shall include full compensation for labour, tools materials and equipment, haulage, stockpiling and incidental costs required for carrying out the work.

10-80- 005 : Haulage (Overhaul beyond 1.5km)

The Contractor shall load the excavated gravel, haul by appropriate equipment and off-load on the road as directed by the Engineer. Where the quantity delivered in any load falls short of the equipment capacity, off-loading shall only be permitted after the agreed spacing is adjusted accordingly.

No vehicle with a capacity of greater than 10 tonnes shall be permitted to off-load gravel directly on the prepared formation. Any greater loads shall be dumped in stockpiles off-road and transported to the formation areas by appropriate means.

Where loads supplied are found to contain material other than from the approved quarry and are of unacceptable quality, the Contractor shall remove them from site at the Contractor's expense.

Work Method:

The Contractor shall use both **Labour** and **Equipment** to carry out this Item.

Quality Control:

No haulage equipment shall be used until its capacity has been ascertained by the Engineer

The quality of gravel dumped on the road shall be according to the Specifications

The quantity of material delivered in each load shall be checked before dumping is allowed

The distance between the stacks shall be checked to ensure the required compacted thickness will be achieved.

Measurement Unit: m³km (Overhaul)

The Contractor shall allow in the rates for item 10-80-007 for a 'free' haul distance of 1.5km. The 'overhaul' shall be the distance, greater than 1.5km, to the centre point of the section where the gravel is being dumped and processed, measured along the shortest route as determined by the Engineer.

The measurement of overhaul shall be the product of the volume of the gravel hauled and the distance to the centre point as indicated above.

Payment

The unit rate shall include full compensation for labour, tools, equipment, and incidental costs necessary to carry out the work.

Excavation, Free haul, Spreading and Compaction of Gravel

10-80-007 - Labour

10-80-008 - Equipment

Excavation of Gravel - Labour - Equipment

Gravel shall be excavated from quarries approved by the Engineer, and the Contractor shall inform the Engineer if the quality/availability of the gravel changes during the course of excavation. Excavation and loading shall normally be by labour unless, at the request of the Contractor, the Engineer allows the use of equipment.

Stones and boulders with one dimension greater than 80mm shall be removed from the excavated gravel and deposited outside the quarry at locations approved by the Engineer. Such stones and boulders may be reused in other parts of Works with the approval of the Engineer.

Work Method:

The Contractor shall use **Labour** and/or **Equipment** to carry out this work, as directed by the Engineer.

Quality Control:

Oversize stones and boulders shall not be loaded for haulage to the road.

Areas containing deleterious material shall not be excavated.

Free haul, spreading and Compaction of Gravel:

The Contractor shall spread and compact gravel material, in a manner to ensure a uniform thickness of the layer across the full width of the carriageway and shaped to the specified camber. Spreading also includes the removal of any oversized stones or boulders, which cannot be broken down to the required size, to spoil dumps. Gravel shall be spread within 24 hours of off-loading.

Compaction of the gravel material shall be carried out from the carriageway edges to the centerline by overlapping passes of the compaction equipment. The number of passes shall be as directed by the Engineer dependent upon the equipment used and the material being compacted. Unless otherwise instructed the moisture content of the material shall be within $\pm 2\%$ of optimum

Where additional moisture is required water shall be applied in an even manner and the rate of application shall be such that no transverse or longitudinal flows occur.

The Engineer may instruct the Contractor to carry out density tests on the compacted material to ensure that an acceptable standard has been achieved.

Work Method:

The Contractor shall use **Labour** and/or appropriate **Equipment** to carry out this item.

Quality Control:

The gravel surface width shall be checked at 100m intervals and shall have a tolerance of $+ / - 50\text{mm}$

Trial holes shall be dug as directed by the Engineer to check the gravel thickness and shall have a tolerance of $+ 5\text{mm} / - 0\text{mm}$. The camber shall be checked at 50m intervals and the maximum tolerance shall be $+ / - 1\%$

The longitudinal profile shall be checked after the compaction of each load to ensure a smooth surface with no corrugations or depressions.

Measurement Unit: m³

The measurement shall be the volume of compacted gravel surfacing measured net according to the Drawings and shall include the excavation and the 1.5km 'free' haul distance.

Payment:

The unit rate shall be the full compensation for labour, tools, equipment and incidental costs required for carrying

out the work.

10-80-010 Restoration of Quarries and Borrow Pits

The Contractor shall level the ground, return the topsoil from the stockpiles, and uniformly spread the material over the full excavation area.

Adequate drainage provisions shall be made to protect the excavation areas, and where necessary appropriate protection measures shall be taken to avoid erosion of the spread topsoil layer. Grass and trees shall be replanted as directed by the Engineer.

Work Method:

The Contractor shall use **Labour** and/or **Equipment** to carry out this item as agreed by the Engineer.

Quality Control:

The Engineer shall check that the required measures have been satisfactorily taken.

Measurement and Payment: Provisional Sum

Payment shall be made on a Day works basis for the labour and equipment as directed by the Engineer

DRAWINGS

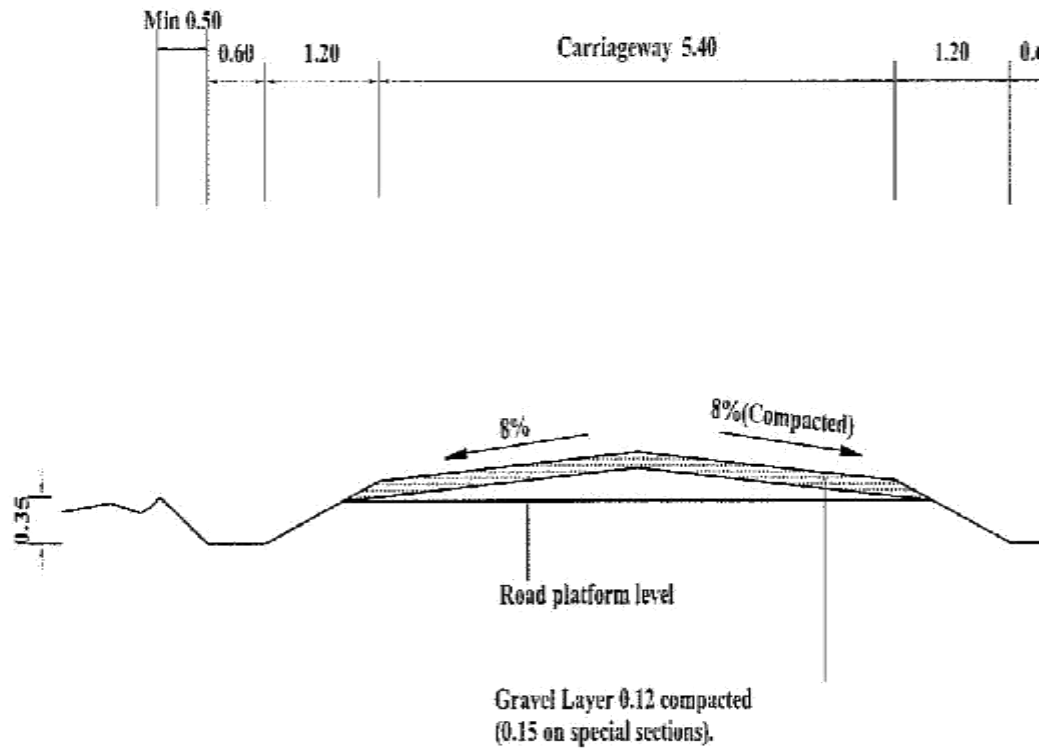

Notes:

1. All dimensions in metres
2. Traffic levels of >200vpd may justify a carriageway width of 6.0m
3. Gravel thickness may be increased as directed by the Engineer

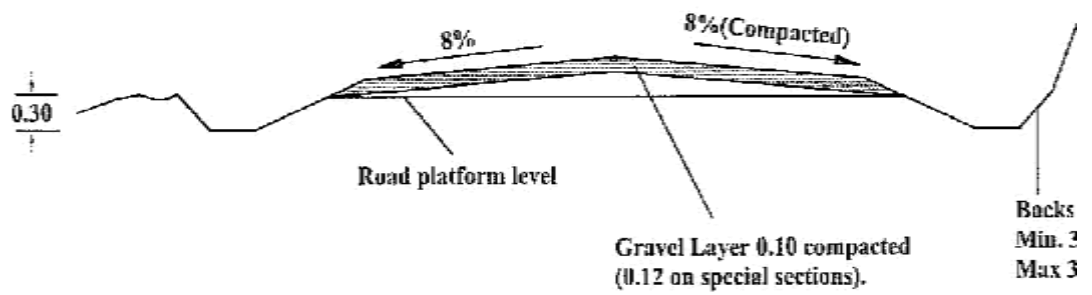
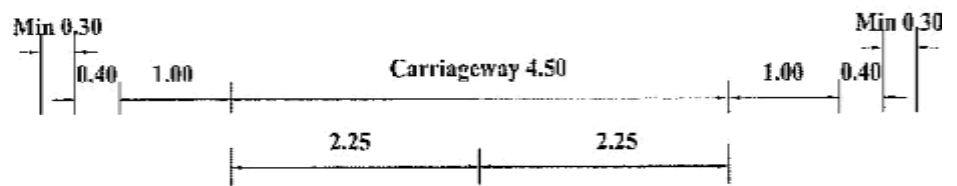

Notes:

1. All dimensions in metres
2. Gravel thickness may be increased as directed by the Engineer

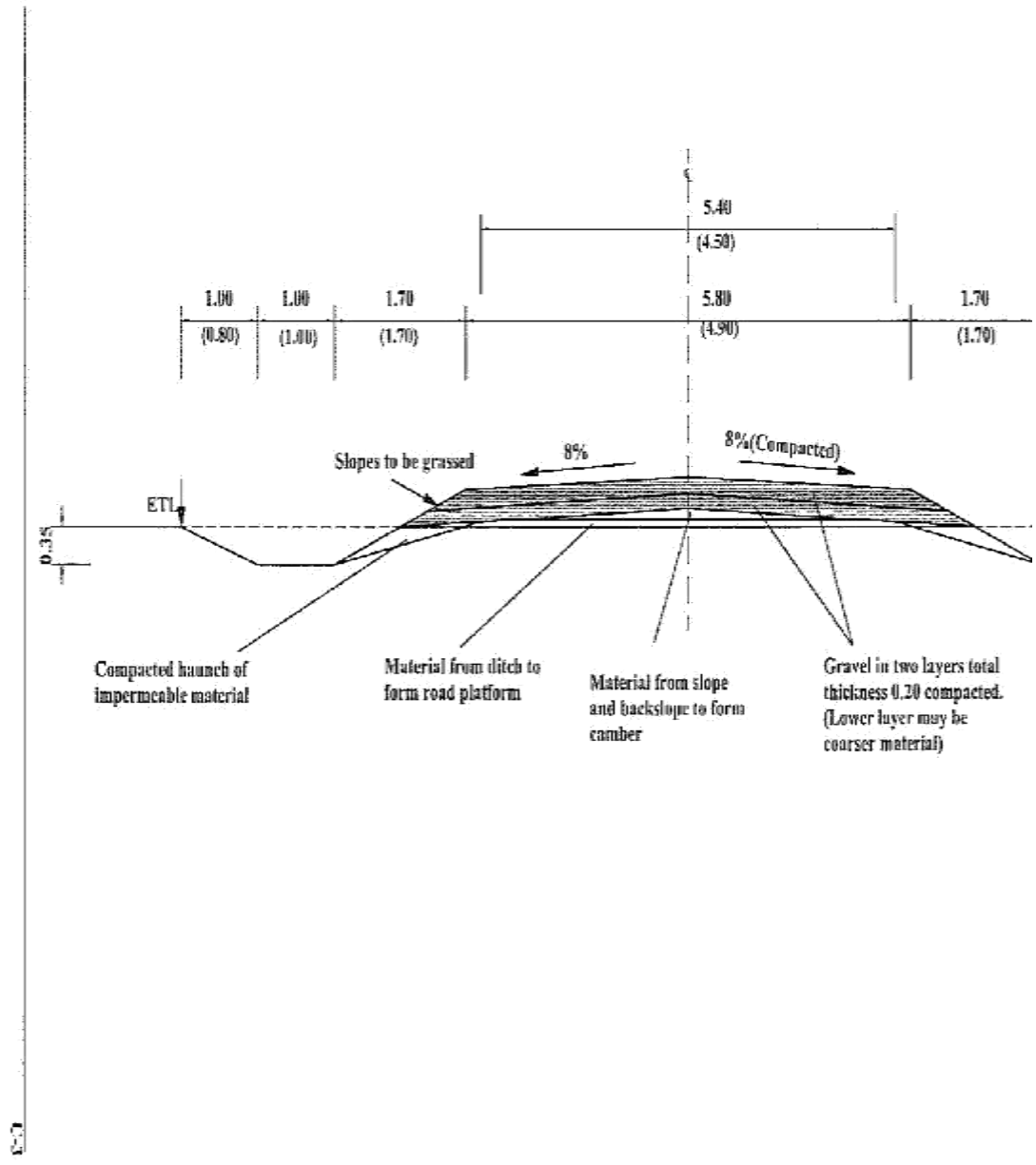

0.30

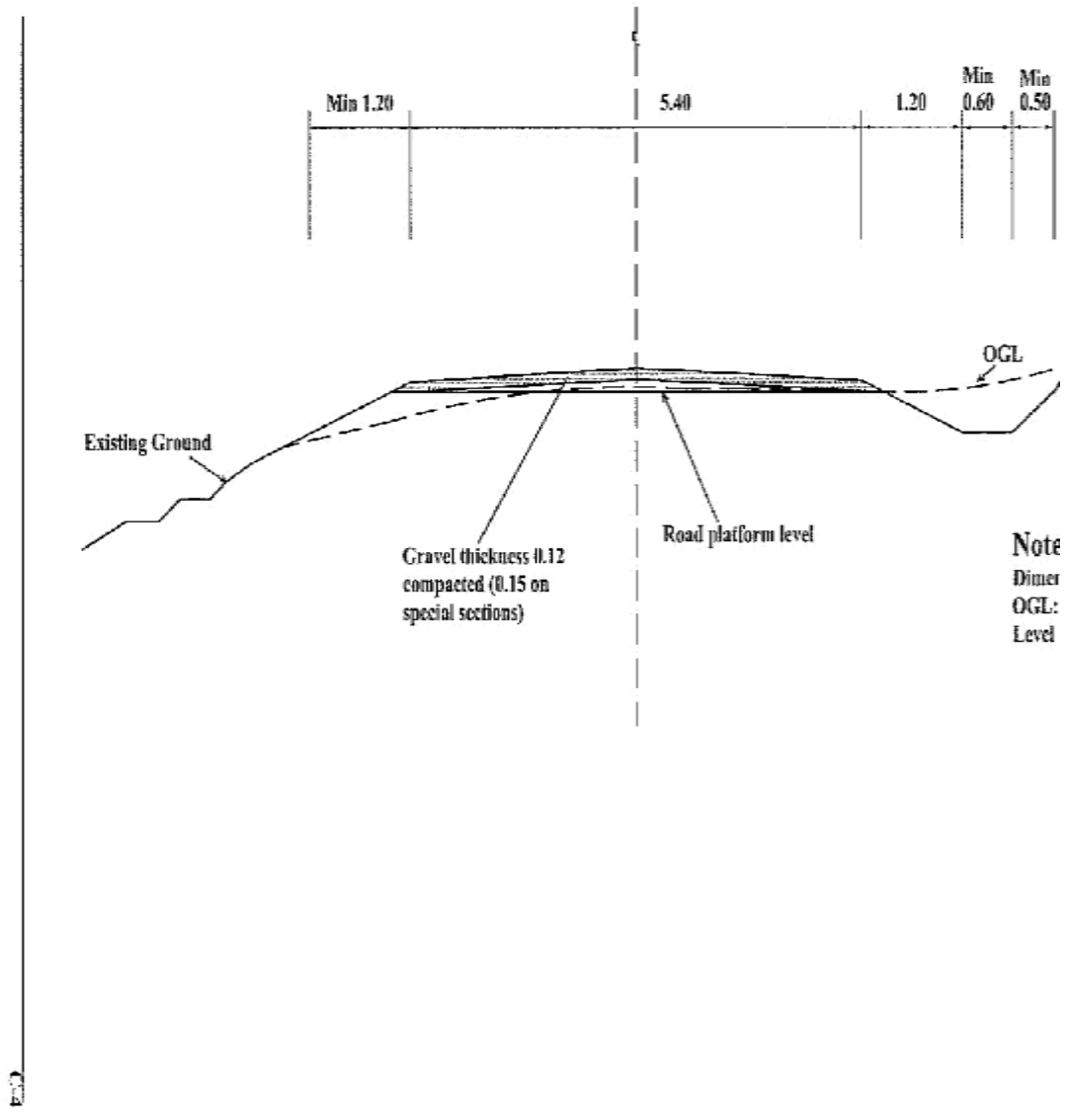
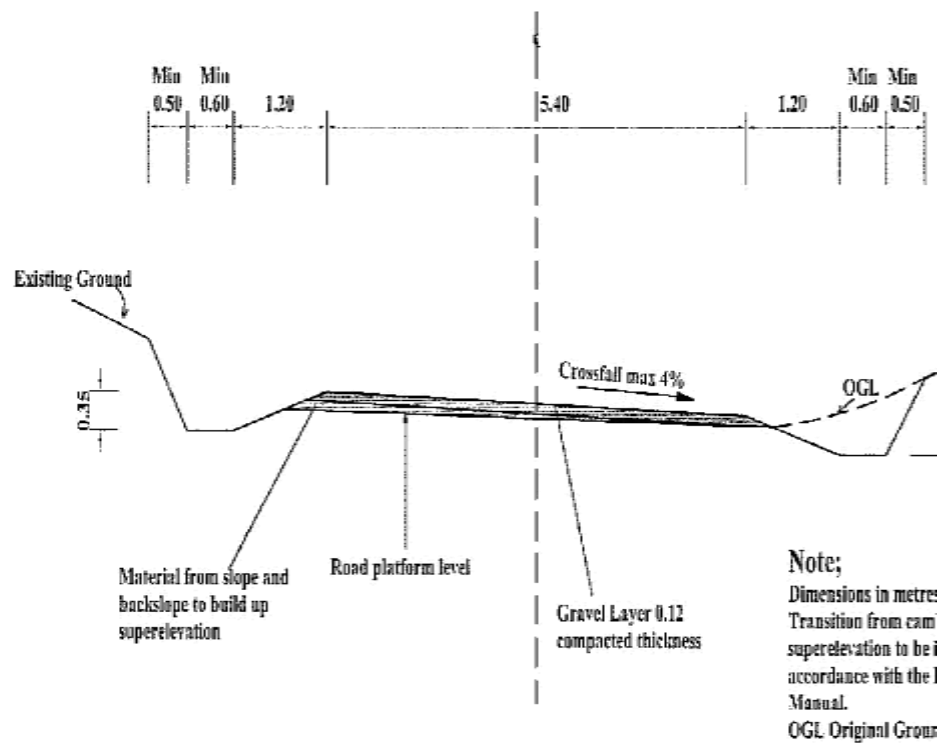
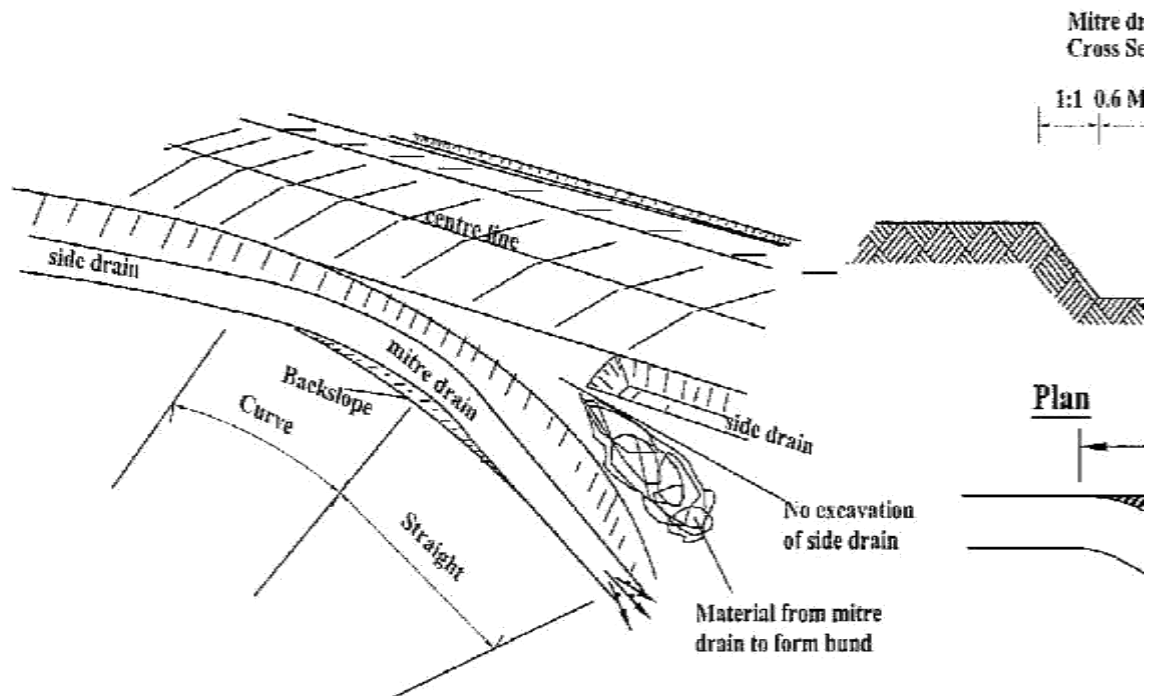

Fig. 2

5.2





Notes

Location, direction and length of the
by the Engineer

Scour checks made of wooden stakes

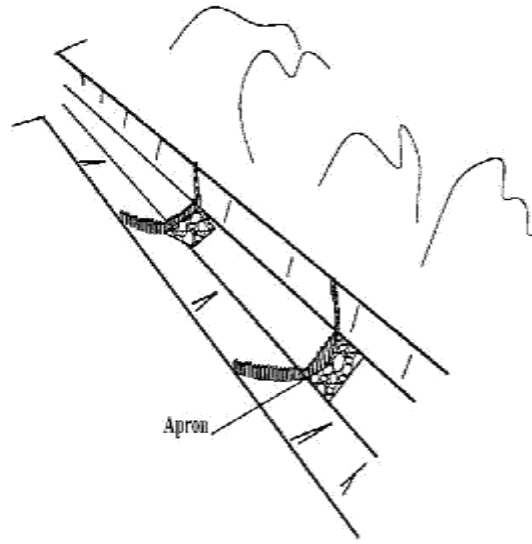

Scour checks made of stones

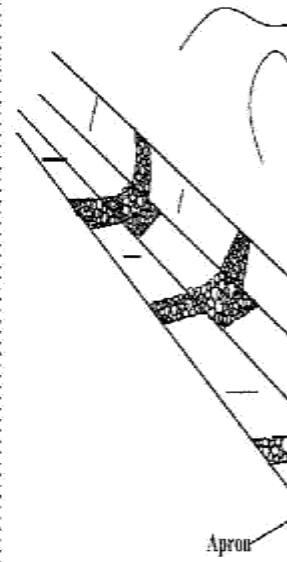

Scour checks made of stones

Cross section

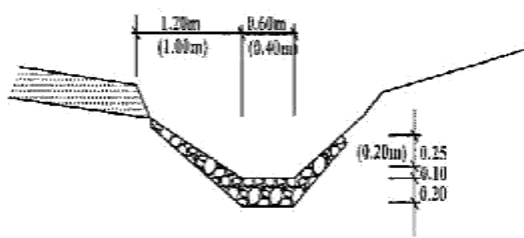

Ground plan

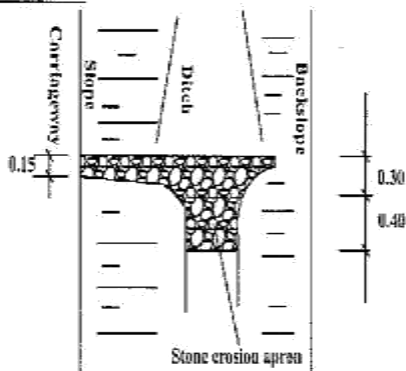

NOTE
1. Dimensions in metres

Scour checks made of stakes

Cross section

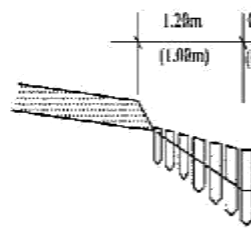

Ground plan

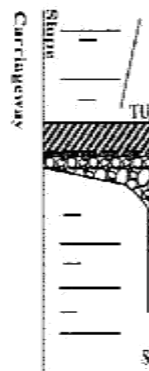

STONE WEIGHT: MIN 10KG
STAKE DIAMETER: MIN. 0.10



SECTION OF MASONRY SCOUR CHECK

Note
 (Dimensions in mm)

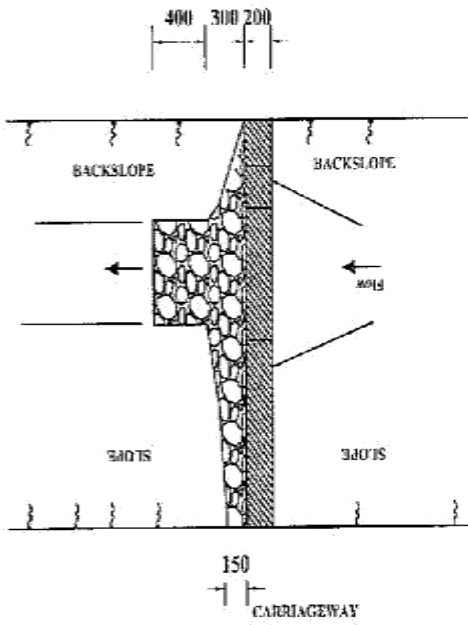

PLAN OF DRAIN WITH SCOUR CHECK

Cross-Section	Spaced in mm			Ravine (m/s)	Length of (m/s)	Average slope (m/s)
	Length	Width	Depth			
A	2400	300	550	0.22	0.28	0.18
B	2000	200	500	0.18	0.2	0.14

SECTION OF CONCRETE SCOUR CHECK

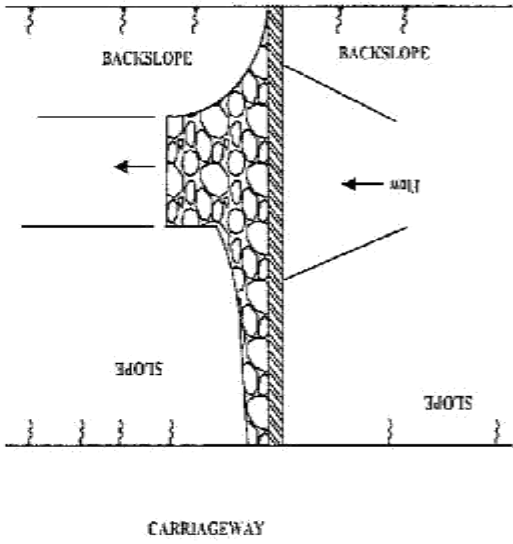

NOTE
1. Dimensions in mm

PLAN OF DRAIN WITH SCOUR CHECK

Cross-Section	Sizes in mm		Excav (m ³)	Concrete (m ³)	Apron stone pitching (m ³)
	Length	Width Depth			
A	2400	100 550	0.13	0.15	0.18
B	2000	100 500	0.10	0.09	0.14

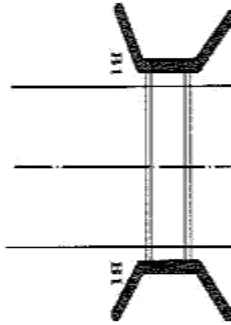

TYPE Z(ENTRY ONLY)

TYPE A(ENTRY AND EXIT ON ACCESS)

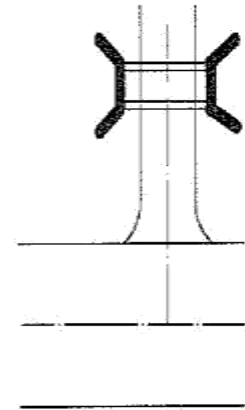
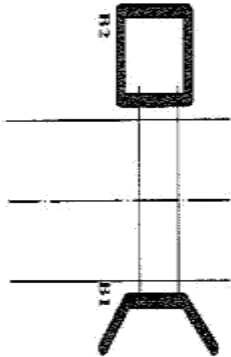

NOTE
 1. The code numbers specify the shape and function and the code letter denotes the material:
 A = Concrete block
 B = Stone masonry
 C = Concrete

SECTION A-A

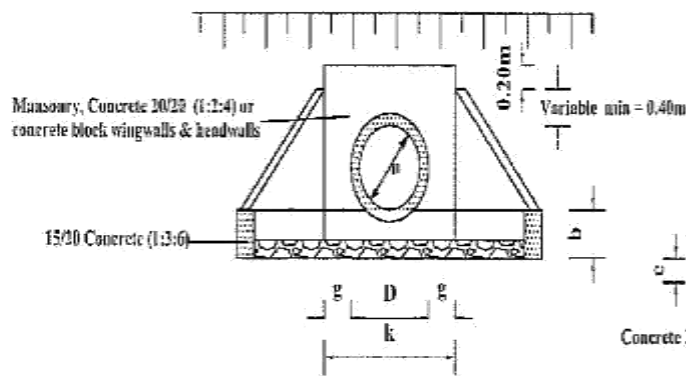

SECTION B-B

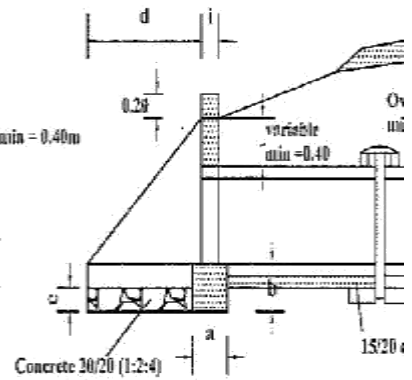

PLAN

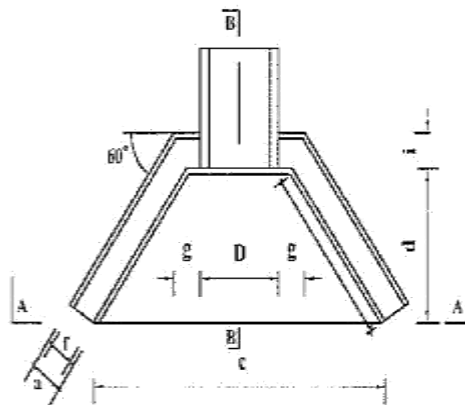

CULVERT TYPES	
X-SECTION WIDTH m	No. of pipes
4.50	6
5.50	7
6.50	8

PIPE DIAMETER IN M	UNIT	TYPE A and C CONCRETE BLA		
		450	600	
a	FOUNDATION	m	0.30	0.30
b	FOUNDATION	m	0.30	0.30
c	FOUNDATION	m	2.20	2.35
d	APRON	m	1.00	1.00
e	APRON	m	0.20	0.20
f	WALL	m	0.20	0.20
g	WALL	m	0.30	0.36
h	WALL	m	1.15	1.15
i	WALL	m	0.20	0.20
k	APRON	m	1.05	1.20
MATERIAL REQUIREMENT				
FOUNDATION (concrete)		m ³	0.30	0.32
HEAD/WINGWALLS (Concrete/Masonry)		m ³	0.42	0.49
APRON (concrete)		m ³	0.33	0.36

SECTION A-A

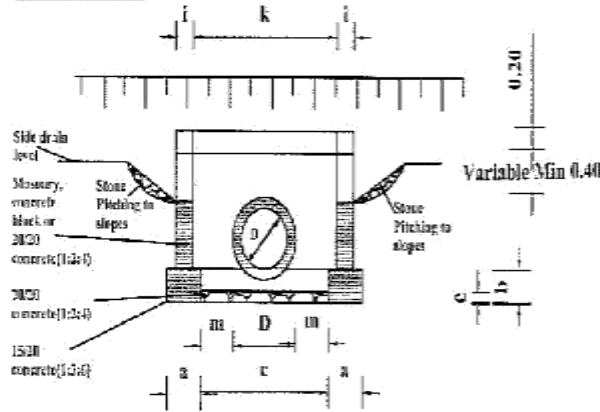

SECTION B-B

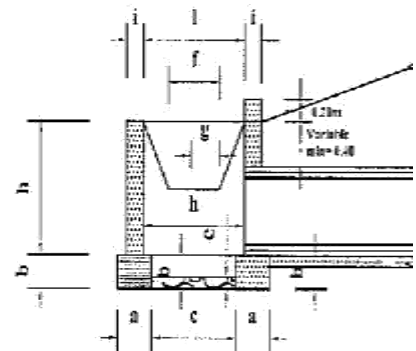

PLAN

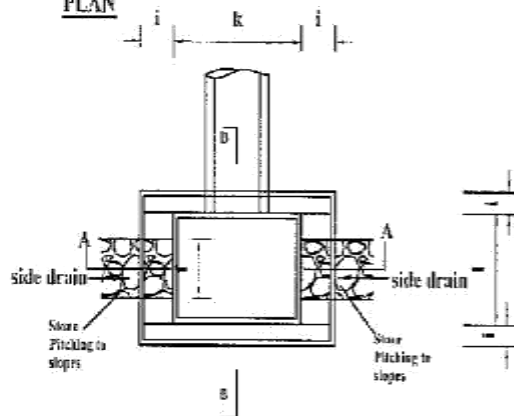

DIMENSIONS AND MATERIAL REQUIREMENTS

PIPE DIAMETER IN (M)	TYPE A CONCRETE BLOCKS			TY M'
	450	600	900	
DIMENSION	UNIT			
a FOUNDATION	m	0.30	0.30	0.4
b FOUNDATION	m	0.30	0.30	0.3
c FOUNDATION	m	1.10	1.19	1.40
d APRON	m	0.90	0.90	0.90
e APRON	m	0.20	0.20	0.2
f DROP INLET	m	0.60	0.60	0.6
g DROP INLET	m	0.30	0.40	0.60
h DROP INLET	m	0.60	0.80	1.20
i DROP INLET	m	0.20	0.20	0.20
k DROP INLET	m	1.20	1.20	1.50
l DROP INLET	m	1.00	1.01	1.00
m DROP INLET	m	0.28	0.31	0.30

MATERIAL REQUIREMENT

FOUNDATION (concrete)	m ³	0.47	0.47	0.52	0.1
HEAD/WINGWALLS (Concrete/Masonry)	m ³	0.50	0.72	1.15	1.2
APRON (concrete)	m ³	0.24	0.24	0.20	0.2

SECTION A-A

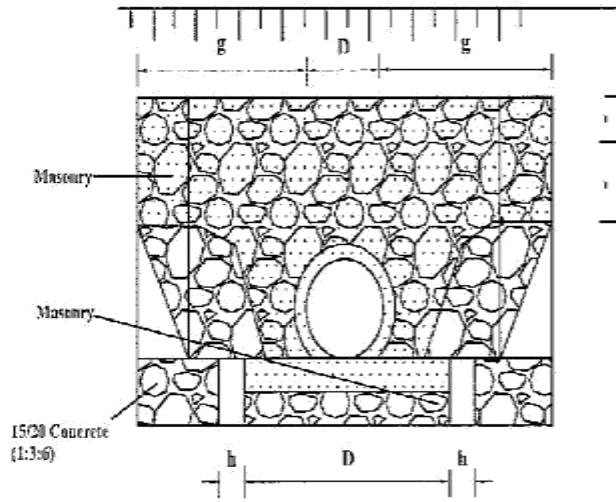

SECTION B-B

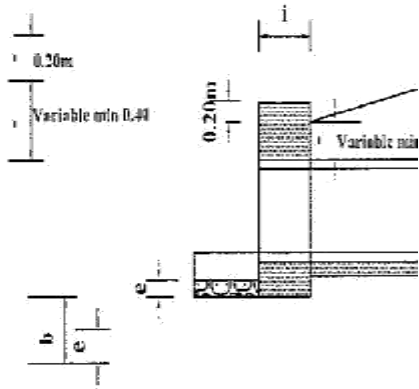

PLAN

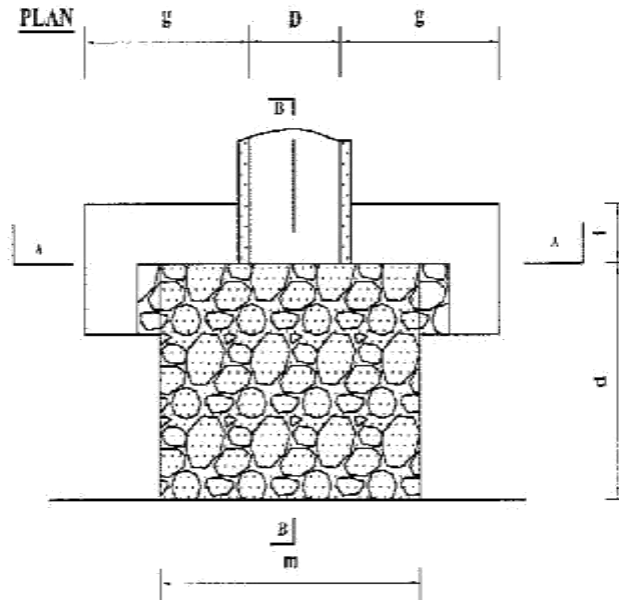

DIMENSIONS AND

PIPE DIAMETER (M)	
DIMENSION	
a	FOUNDATION
b	FOUNDATION
c	FOUNDATION
d	APRON
e	APRON
f	HEADWALL
g	HEADWALL
h	HEADWALL
i	HEADWALL
m	FOUNDATION
MATERIAL REQ'D	
FOUNDATION (concrete)	
HEAD/WING (Concrete/Masonry)	
APRON (concrete)	

SECTION A-A

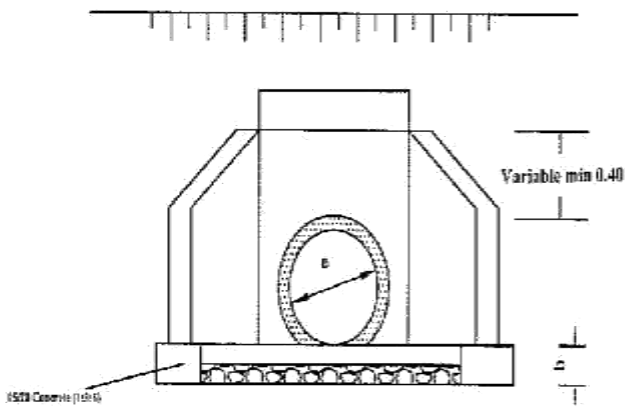

PLAN

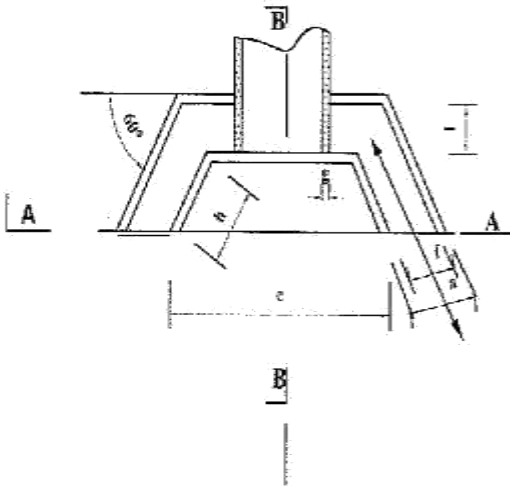

SECTION B-B

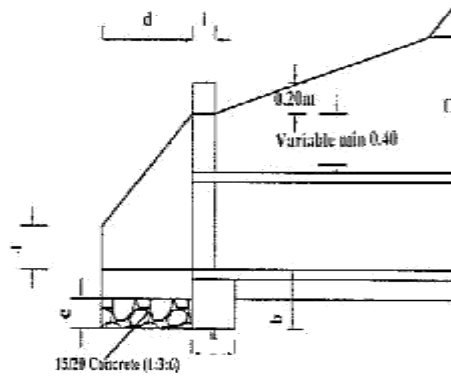

DIMENSIONS AND MATERIAL REQUIREMENTS

PIPE DIAMETER IN (M)	DIMENSION	UNIT	TYPE A (CONCRETE BLOCKS)	
			450	600
a	FOUNDATION	m	0.20	0.20
b	FOUNDATION	m	0.30	0.30
c	APRON	m	1.34	1.49
d	APRON	m	0.60	0.60
e	APRON	m	0.20	0.20
f	WINGWALLS	m	0.20	0.20
g	WINGWALLS	m	0.10	0.10
h	HEADWALLS	m	0.60	0.60
i	HEADWALLS	m	0.20	0.20
k	HEADWALLS	m	0.65	0.65
l	HEADWALLS	m	0.40	0.40
MATERIAL REQUIREMENT				
FOUNDATION (concrete blocks)			0.18	0.20
HEAD/WINGWALLS (Concrete/Masonry)			0.28	0.32
APRON (concrete)			0.12	0.14

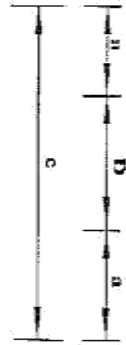
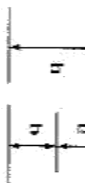

Diameter (D)	450 (mm)	600 (mm)	900 (mm)
a	0.15	0.20	0.20
b	0.10	0.15	0.15
c	0.86	1.12	1.48
d	0.56	0.72	1.08
e	0.14	0.18	0.27
f (min)	0.34	0.45	0.68
g	-	-	-
h	0.24	0.33	0.42
i	-	-	-
Concrete	Volume in (m ³ /m)		
Class 15/20	0.24	0.24	0.24
Application	-Fair subgrade condition -Overfill \geq 75% of the pipe diameter -Seasonal water flow only		
Remarks	Material for back/overfill shall be approved by the Engineer		

Diameter (D)	450 (mm)	600 (mm)	900 (mm)
a	0.15	0.20	0.20
b	0.10	0.15	0.15
c	0.86	1.12	1.48
d	0.56	0.72	1.08
e	0.28	0.36	0.54
f	0.34	0.45	0.68
g	-	-	-
h	0.38	0.51	0.69
Concrete	Volume in (m ³ /m)		
Class 15/20	0.20	0.37	0.56
Application	-Fair to poor subgrade condition -Overfill \geq 75% of the pipe diameter -Seasonal water flow only		
Remarks	Material for back/overfill shall be approved by the Engineer		

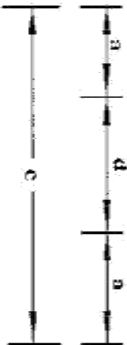
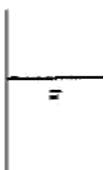
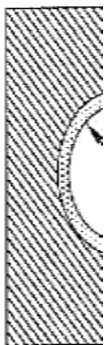
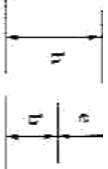

Diameter (D)	450 (mm)	600 (mm)	900 (mm)
a	0.15	0.20	0.20
b	0.10	0.15	0.15
c	0.86	1.12	1.48
d	0.86	1.12	1.48
e	0.42	0.54	0.81
f (only)	0.23	0.3	0.45
g	-	-	-
h	0.52	0.69	0.96
i	-	-	-
Concrete	Volume in (m ³ /m)		
Class 15/20	0.26	0.47	0.71

Diameter (D)	450 (mm)	600 (mm)	900 (mm)
a	0.15	0.20	0.20
b	0.10	0.15	0.15
c	0.86	1.12	1.48
d	0.86	1.12	1.48
e	0.42	0.54	0.81
f (only)	0.23	0.3	0.45
g	-	-	-
h	0.52	0.69	0.96
i	-	-	-
Concrete	Volume in (m ³ /m)		
Class 15/20	0.26	0.47	0.71

Diameter (D)	450 (mm)	600 (mm)	900 (mm)
a	0.15	0.20	0.20
b	0.10	0.15	0.15
c	0.86	1.12	1.48
d	0.86	1.12	1.48
e	0.46	0.52	0.78
f (only)	0.15	0.15	0.15
g	0.15	0.15	0.15
h	0.81	1.02	1.38
i	0.28	0.35	0.45
Concrete	Volume in (m ³ /m)		
Class 15/20	0.37	0.61	0.92

Diameter (D)	450 (mm)	600 (mm)	900 (mm)
a	0.15	0.20	0.20
b	0.10	0.15	0.15
c	0.86	1.12	1.48
d	0.86	1.12	1.48
e	0.46	0.52	0.78
f (only)	0.15	0.15	0.15
g	0.15	0.15	0.15
h	0.81	1.02	1.38
i	0.28	0.35	0.45
Concrete	Volume in (m ³ /m)		
Class 15/20	0.37	0.61	0.92

Remarks: Material for back/overfill shall be approved by the Engineer

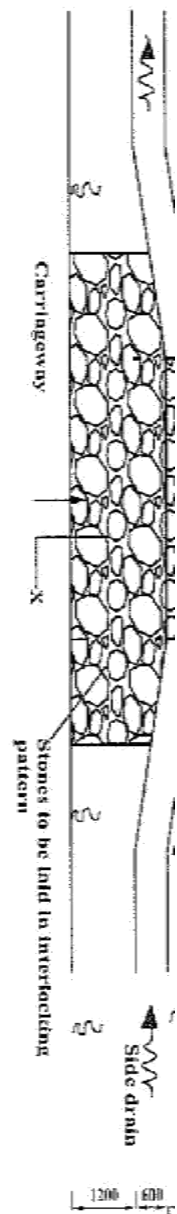

150mm Grouted Stone Pitching
(Cement mortar 1:4)

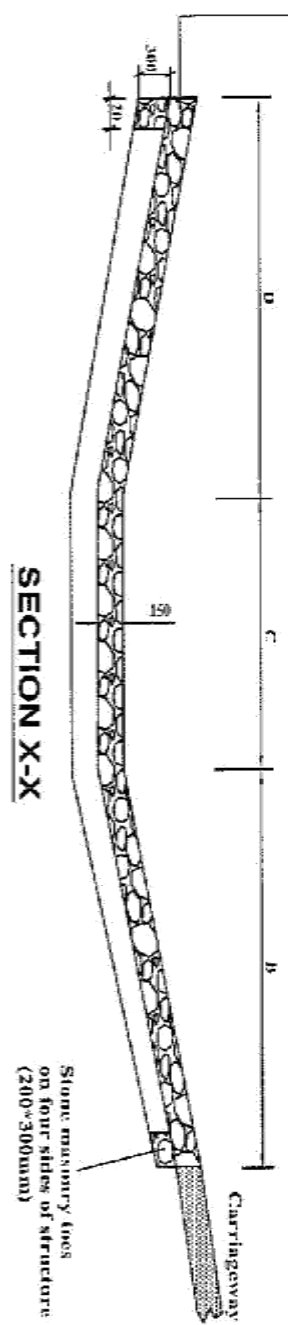

SECTION X-X

QUANTITIES TABLE

Cross section	DIMENSIONS					Excavation(m ³)	Stone masonry (m ³)	150mm Grouted stone pitching(m ³)
	A	B	C	D	E			
A	4000	1800	600	1800	4200	7.5	1.30	21.75
	6000	1800	600	1800	4200	10.00	1.60	30.15
B	4000	1400	400	1800	3600	7.00	1.20	18.30
	6000	1400	400	1800	3600	9.00	1.50	25.50

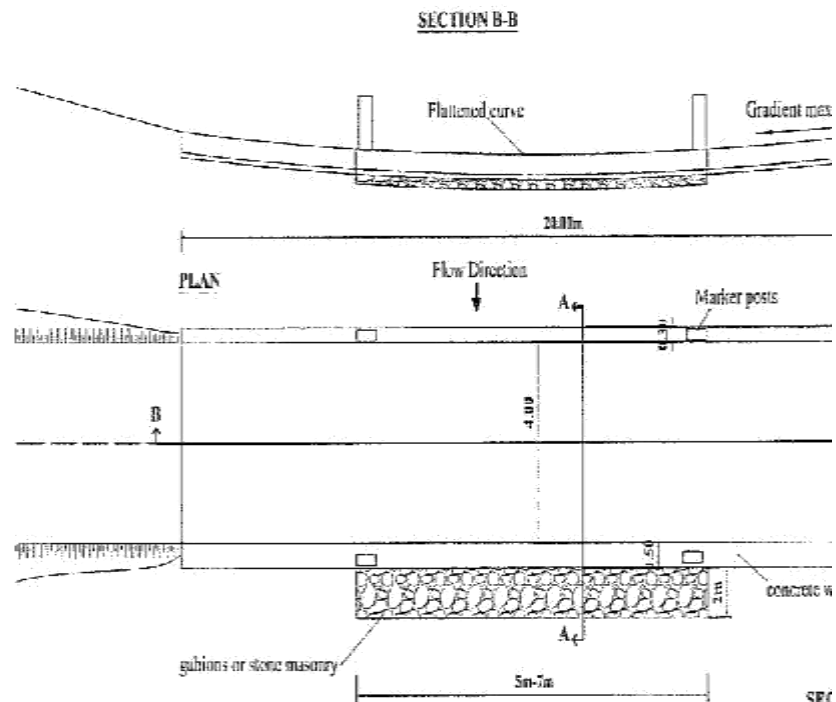

Material : All concrete Class 20/20 (1:2:4)

- 1 Concrete wall : 16m³
- 2 Concrete slab : 24m³ or stone masonry
- 3 Concrete toe : 8m³ or stone masonry
- 4 Gabions / mattress rock fill: 4.3m³ or stone masonry
- 5 Gabions / mattress: 36m²
- 6 Marker posts - precast concrete: 4 no.
- 7 Excavation (slab + toes + gabions) 54.2m³

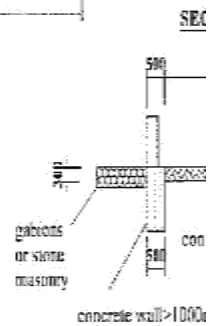

SECTION A-A

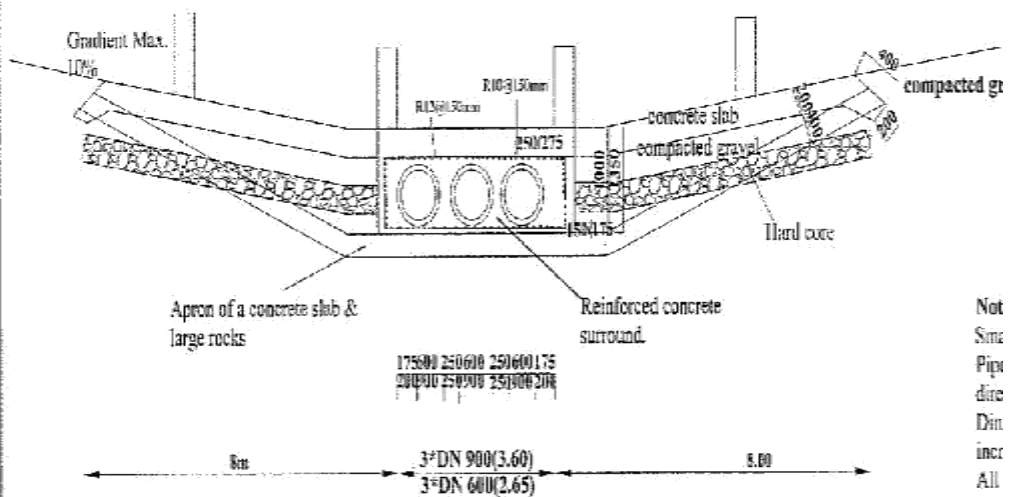

PLAN

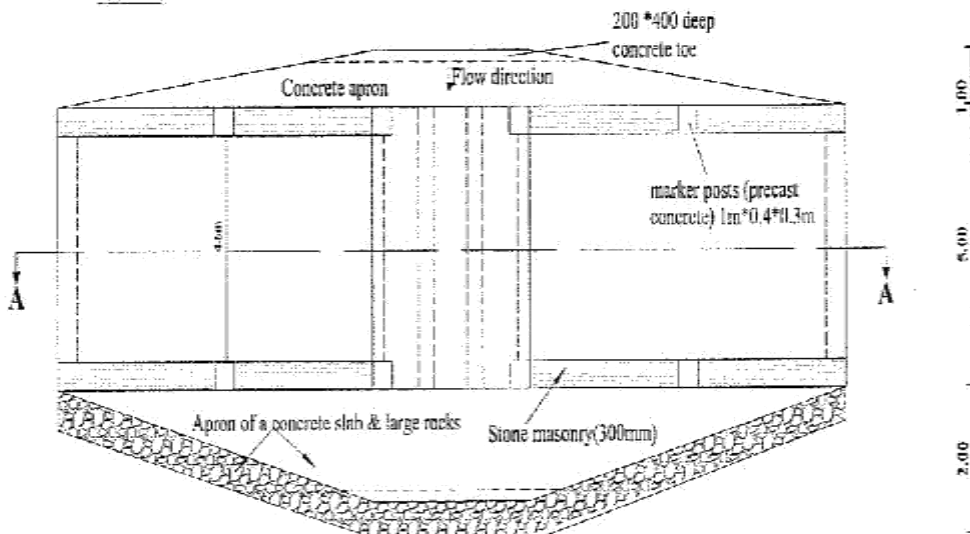



2. EDGE BEAM OF LARGE STONES



3. EDGE BEAM SECURED AND LARGE STONES LAID ON EDGE

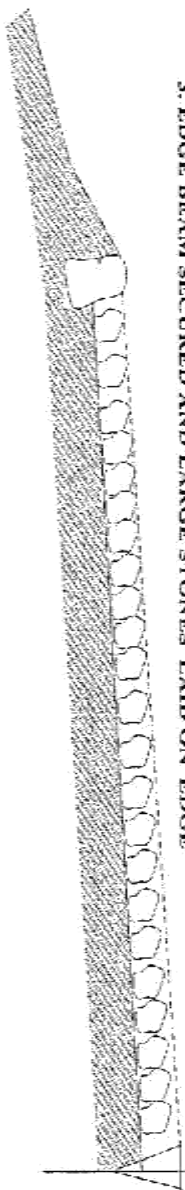

4. LARGE STONES WEDGED WITH SMALLER ONES THEN RINDDED

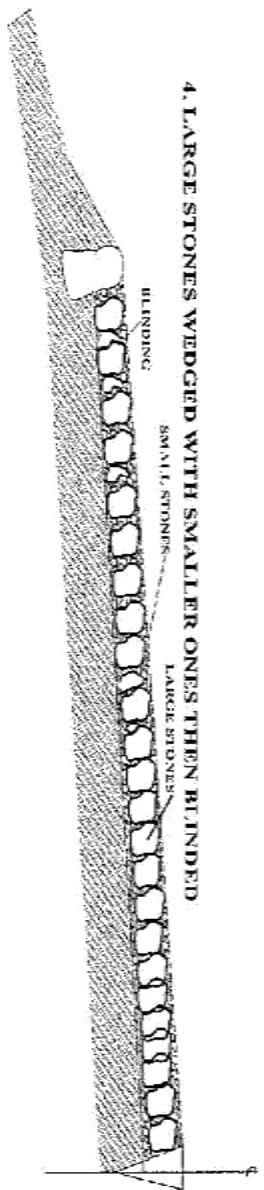

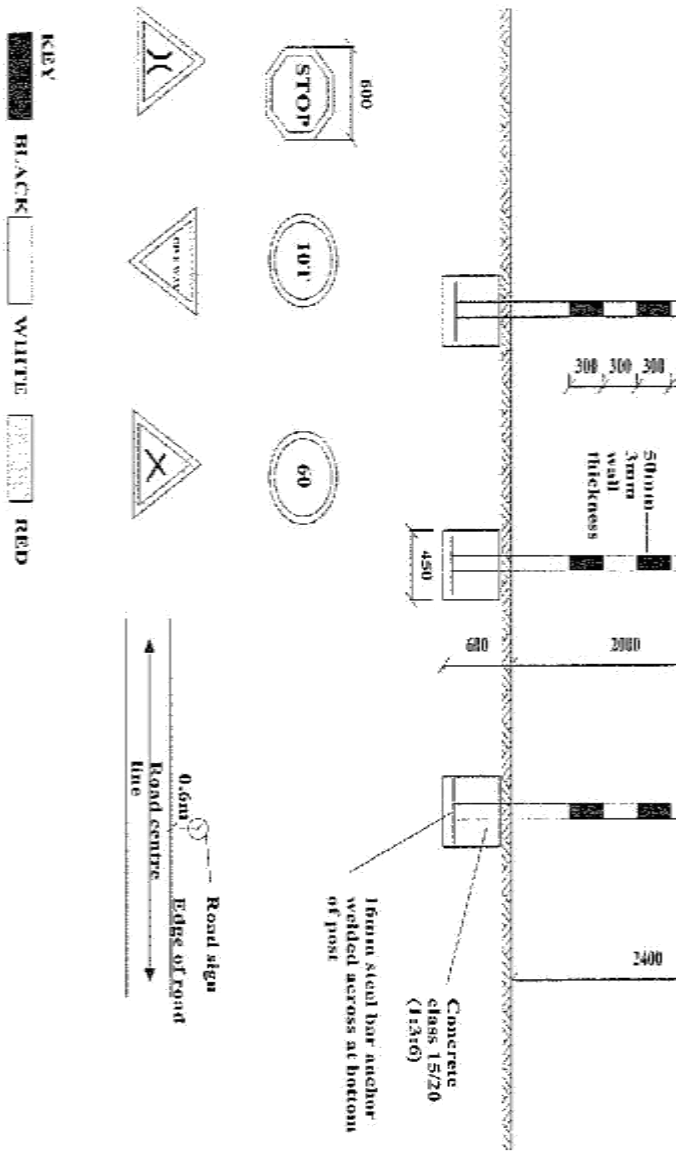

1. The type of sign required and their location shall be as shown on the Road Plan or as directed by the Engineer.
2. Sign plate to be 2mm thick mild steel plate.
3. Sign post to be 50mm fixing clamps/brackets.
4. Sign plate to be fixed to steel tube by 5 Nos M10 bolts and 50mm fixing clamps/brackets.
5. Sign paints shall be reflective.
6. The sign plate and post shall be treated by applying two coats of lead red oxide paint before applying a priming and two finish coats of approved paints. Paints used shall have a hard, durable and glossy finish.

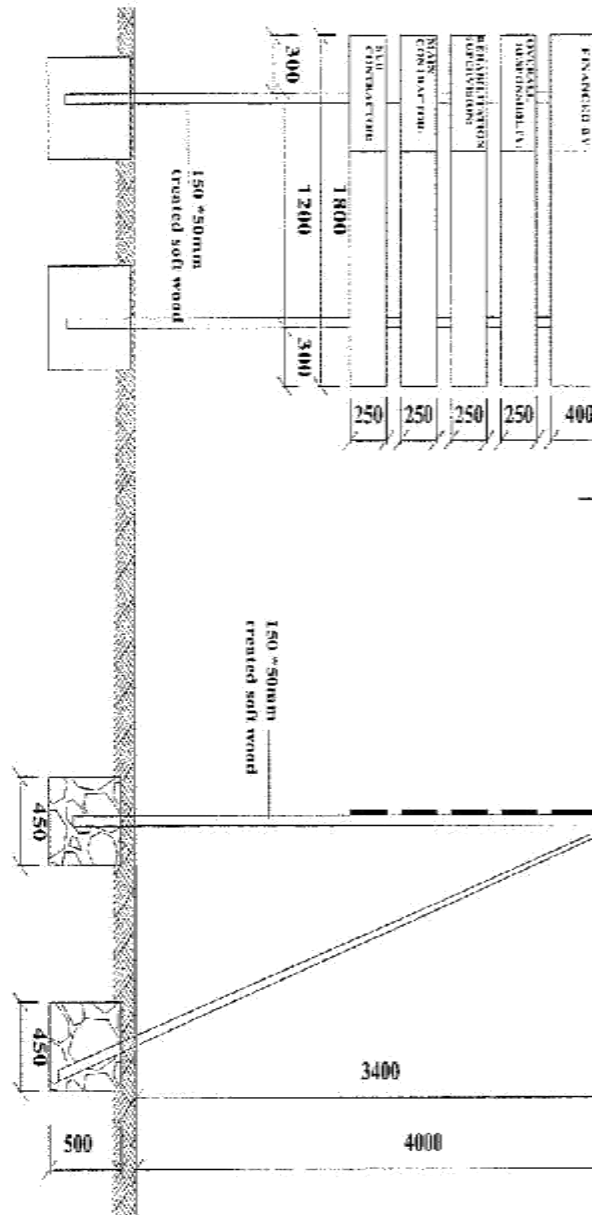

WHITE
 BLACK

- NOTES**
1. The wording of the project sign board and the location to be as directed by the Engineer.
 2. Materials to be used for fabrication of signboard shall be pressure impregnated treated softwood timber
 3. Wording board posts to be attached to the posts with galvanised nails
 4. Project board posts and struts to be embedded in concrete class 20/20(1:2:4)

PREAMBLE TO BILLS OF QUANTITIES

1. The Bills of Quantities form part of the Contract Documents and are to be read in conjunction with the Instructions to Tenderers and these Documents.
2. The prices and rates to be inserted in the Bills of Quantities are to be the full, inclusive value of the work described under the several items including all costs and expenses which may be required in and for the execution of the work described and for the Contractor's overheads and profits. The rates shall be VAT exclusive but include all other taxes, levies and fees applicable. The rates shall be based on the Works being carried out in accordance with the R2000 Strategy of using optimum labour resources.
3. Each item in the Bills of Quantities contains only a brief description of the required work. Fuller details and descriptions of the work to be done, the materials to be used, the standards of workmanship, methods of measurement and payment are to be found in the various sections of the Specifications and on the Drawings.
4. The Quantities set out in the Bills of Quantities are estimated and represent substantially the work to be carried out. There is no guarantee that the Contractor will be required to carry out all the quantity of work indicated under any one particular item or group of items in the Bills of Quantities. The basis of payment shall be the Contractor's rates and the quantities of measured work done in fulfilment of the obligations under the Contract.
5. Work shall be carried out under day works items only at the direction, and with the approval, of the Engineer. The Contractor shall enter rates in the day works Schedule of Rates, which shall reflect the realistic costs, including overheads and profit, of each item. If, in the opinion of the Engineer, a rate is unreasonably high or low, the Contractor may be required to amend the rate to the satisfaction of the Engineer.

BILLS OF QUANTITIES

(As generated from RMS)

RoadCode E363

Structure:

Package: KeRRA/011/TUR/39/2-36-18|19-537

Contractor

0

Bill of Quantities		Page: 1
	Summary	Project:

No.10	WORKS				:	
Item No.	Description	Units	Quantity	Unit Bid Rate(Ksh)	Amount KSh	Technology
10-50-001	Heavy grading without watering or compaction instructed by the Engineer	M ²	189000		-	MB
					-	
					-	
					-	
					-	
					-	
					-	
					-	
					-	
					-	
					-	
					-	
					-	
					-	
					-	
					-	
					-	
					-	
					-	
					-	
					-	
Total Carried Forward to Summary:					-	

Road Code E363

Section Name Napakaelim-Lokori

Package: KeRRA/011/TUR/39/2-36-18|19-537
 Contract or 0

