



RT/59

# KENYA RURAL ROADS AUTHORITY

## EMBU REGION

(22% RMLF– RUNYENJES CONSTITUENCY)

### ROUTINE MAINTENANCE OF MUFU-KARUNGU (C406) ROAD

**TENDER No. KERRA/011/EBU/39/RUN/22%/2-23-20|21-006**

**BID DOCUMENT: -**

- FORM OF BID
- APPENDIX TO FORM OF BID
- INSTRUCTION TO BIDDERS
- QUALIFICATION CRITERIA
- FORM OF AGREEMENT
- SCHEDULE OF SUPPLEMENTARY INFORMATION
- CONDITIONS OF CONTRACT
- SPECIAL SPECIFICATIONS
- DRAWINGS
- BILLS OF QUANTITIES

DECEMBER, 2020

<b>Deputy Director</b> Kenya Rural Roads Authority P.O Box 2718 <u>EMBU</u>	<b>Director (RAM)</b> Kenya Rural Roads Authority P.O Box 48151 <u>NAIROBI</u>	<b>Director General</b> Kenya Rural Roads Authority P.O. Box 48151 <u>NAIROBI</u>
--	---	--

## TABLE OF CONTENTS

	<u>PAGE</u>
INTRODUCTION .....	3
SECTION I - INVITATION FOR TENDERS.....	4
SECTION II - INSTRUCTIONS TO TENDERERS .....	6 - 18
APPENDIX TO INSTRUCTIONS TO TENDERERS .....	19
SECTION III - CONDITIONS OF CONTRACT, PART -GENERAL CONDITIONS	24
SECTION IV- CONDITIONS OF CONTRACT, PART II -CONDITIONS OF PARTICULAR APPLICATION .....	27
SECTION V -SPECIFICATIONS .....	44
SECTION VI - DRAWINGS .....	55
SECTION VII - BILLS OF QUANTITIES .....	56
SECTION VIII - STANDARD FORMS .....	57

## INTRODUCTION

- 1.1 This standard tender document for procurement of works has been prepared for use by procuring entities in Kenya in the procurement of works (i.e. Roads, Bridges, Airports and Dams).
- 1.2 The following guidelines should be observed when using the document:-
  - (a) Specific details should be furnished in the tender notice and in the special conditions of contract (where applicable). The tender document issued to tenderers should not have blank spaces or options.
  - (b) The instructions to tenderers and the General Conditions of Contract should remain unchanged. Any necessary amendments to these parts should be made through Appendix to instructions to tenderers and special conditions of contract respectively.
- 1.3
  - (a) Information contained in the invitation to tender shall conform to the data and information in the tender documents to enable prospective tenderers to decide whether or not to participate in the tender and shall indicate any important tender requirements
  - (b) The invitation to tender shall be as an advertisement in accordance with the regulations or a letter of invitation addressed to tenderers who have been prequalified following a request for prequalification.
- 1.4 This document is based on PART 1 of the latest Edition of the International Federation of Consulting Engineers (*Federation Internationale des Ingenieurs Con Seils - FIDIC*) General Conditions of Contract for works of Civil Engineering.
- 1.5 The cover of the tender document should be modified to include -:
  - i. Tender number.
  - ii. Tender name.
  - iii. Name of procuring entity.

## SECTION I

### INVITATION TO TENDER

**Date: 3<sup>rd</sup> December, 2020**

The Kenya Rural Roads Authority is a state corporation established under the Kenya Roads Acts 2007 with the responsibility for the Management, Development, Rehabilitation and Maintenance of Rural Roads. The Authority hereby invites bids from suitably qualified firms for Routine Maintenance of Mufu-Karungu (C406) Road in Runyenjes Constituency of Embu Region to be funded under the 22% RMLF for the financial year 2020/2021. Interested eligible contractors may obtain **further information and inspect tender documents** from the **Procurement Office in Embu** during the normal working hours Monday – Friday. The Bid documents will be available from the **3<sup>rd</sup> December, 2020** from the regional office, Embu upon payment of non-refundable fee of Kshs. **1,000/=** (One Thousand Shillings Only) by bankers cheque in favour of Kenya Rural Roads Authority". Tender documents can also be downloaded free of charge from the KeRRA website, [www.kerra.go.ke](http://www.kerra.go.ke).

Bidders for the above tenders **MUST** meet the following requirements:

- (i) Prequalified for the category of works specified and in the respective constituency during the 2019/20 Financial year.
- (ii) Provide a certified copy of certificate of incorporation
- (iii) Provide a certified copy of KRA Pin certificate & VAT certificate
- (iv) Provide a certified copy of certificate of registration with the National Construction Authority in Category NCA 8 and above." (Road Works)
- (v) Certified copy of current contractor's practising licence of the National Construction Authority in Category NCA 8 and above.
- (vi) Proof of having opened a Bank Account
- (vii) Certified Current Business Permit
- (viii) Certified Copy of Current CR12 certificate – (12months)
- (ix) Copies of National Identity Card / Valid Passports of Directors
- (x) Signed tender security & declaration form
- (xi) Provide a copy of an up-to-date Tax Compliance Certificate to be confirmed at <http://www.kra.go.ke/notices/tcc-checker.html>
- (xii) Duly filled Confidential Business Questionnaire (CBQ)
- (xiii) Properly filled schedules of information
- (xiv) Duly filled and signed form of tender
- (xv) Serialization of the bid document.
- (xvi) Any errors in the submitted tender arising from a miscalculation of unit price, quantity, subtotal and total bid price shall be considered as a major deviation that affects the substance of the tender and shall lead to disqualification of the tender as non-responsive
- (xvii) Any other condition as stipulated in the Tender Documents

**In addition, Tenderers bidding for the special (YWD) category must provide/attach the following;**

- (xviii) Attach a certified copy of Certificate from the National Treasury (YAGPO, DGW, PWD) in the Small works category/Engineering
- (xix) Certified Copy of IDs of the Company Directors
- (xx) For PWD, attach a certified copy of the ID from the National Council for PLWD.

**Other Requirements includes;**

- a) Past Experience
- b) Equipment Holding
- c) Current Commitment
- d) Key Personnel
- e) Current commitment
- f) Litigation History  
(Details of the same are provided in the tender document)

Procurement of the tenders reserved for the **Youth, Women and Persons Living with Disabilities** shall be based on post qualification and the following details **must** be submitted together with the priced bid. **Failure to submit the information will be a reason for disqualification.**

**Due to Covid-19 Pandemic and consequently the presidential Directives Issued, There shall be no pretender site visit.** However, bidders are encouraged to make personal arrangements to acquaint themselves with the site before submission of bids. Every bidder shall make their arrangements to familiarize themselves with the site conditions and the Road and its features.

Completed bid documents in plain sealed envelope clearly marked **Tender No.** and description, “**DO NOT OPEN BEFORE 11.00AM, 7<sup>th</sup> January, 2020**” should be addressed to:

**The Regional Manager  
Kenya Rural Roads Authority  
P. O. Box 2718  
EMBU**

And deposited in the tender box market in respective Constituency situated at the KeRRA Regional Office at Embu so as to be received on/or before **Thursday, 7<sup>th</sup> January, 2020** at 11.00am. Tender opening will take place immediately thereafter in the presence of the Tenderers or their representatives who may choose to attend.

The Authority reserves the right to accept or reject any or all tenders and to cancel the tender process at any time prior to award of the contract without thereby incurring any liability to the affected tender or tenderer on the ground for the action and is not bound to accept the lowest or any tender.

Peter C. Mwarabu  
**For: REGIONAL MANAGER**  
**EMBU REGION.**

## SECTION II - INSTRUCTIONS TO TENDERERS

### TABLE OF CLAUSES

CLAUSE NUMBERS	DESCRIPTION	PAGE
<u>GENERAL</u>		
1.	Definitions .....	7
2.	Eligibility and Qualification Requirements .....	7
3.	Cost of Tendering .....	8
4.	Site Visit .....	9
<u>TENDER DOCUMENT</u>		
5.	Tender Documents .....	10
6.	Clarification of Tender Documents .....	10
7.	Amendment of Tender Documents .....	11
<u>PREPARATION OF TENDER</u>		
8.	Language of Tender .....	11
9.	Documents Comprising the Tender .....	11
10.	Tender Prices .....	11
11.	Currencies of Tender and Payment .....	13
12.	Tender Validity .....	13
13.	Tender Surety .....	13
14.	No Alternative Offers .....	14
15.	Pre-tender meeting .....	14
16.	Format and Signing of Tenders .....	15
<u>SUBMISSION OF TENDERS</u>		
17.	Sealing and Marking of Tenders .....	15
18.	Deadline and Submission of Tenders .....	16
19.	Modification and Withdrawal of Tenders .....	16
<u>TENDER OPENING AND EVALUATION</u>		
20.	Tender Opening .....	17
21.	Process to be Confidential .....	17
22.	Clarification of Tenders .....	18
23.	Determination of Responsiveness .....	18
24.	Correction of Errors .....	18
25.	Conversion to Single Currency .....	19
26.	Evaluation and Comparison of Tenders .....	20
<u>AWARD OF CONTRACT</u>		
27.	Award Criteria .....	21
28.	Notification of Award .....	21
29.	Performance Guarantee .....	22
30.	Advance Payment .....	22
	Appendix to Instructions to Tenderers .....	23

## **SECTION II - INSTRUCTION TO TENDERERS**

Note: The tenderer must comply with the following conditions and instructions; failure to do so is liable to result in rejection of the tender.

### **GENERAL**

#### **1. Definitions**

- (a) "Tenderer" means any persons, partnership firm or company submitting a sum or sums in the Bills of Quantities in accordance with the Instructions to Tenderers, Conditions of Contract Parts I and II, Specifications, Drawings and Bills of Quantities for the work contemplated, acting directly or through a legally appointed representative.
- (b) "Approved tenderer" means the tenderer who is approved by the Employer
- (c) Any noun or adjective derived from the word "tender" shall be read and construed to mean the corresponding form of the noun or adjective "bid". Any conjugation of the verb "tender" shall be read and construed to mean the corresponding form of the verb "bid."
- (d) "Employer" means the Kenya Rural Roads Authority.

#### **2.0 ELIGIBILITY AND QUALIFICATION REQUIREMENTS**

##### **2.1 Eligibility requirements**

This invitation to tender is open to all tenderers who are qualified as stated in the appendix.

##### **2.2 Qualification Requirements**

To be qualified for award of Contract, the tenderer shall provide evidence satisfactory to the Employer of their eligibility under Sub clause 2.1 above and of their capability and adequacy of resources to effectively carry out the subject Contract. To this end, the tenderer shall be required to update the following information already submitted during prequalification:-

- (a) Details of experience and past performance of the tenderer on the works of a similar nature and details of current work on hand and other contractual commitments.
- (b) The qualifications and experience of key personnel proposed for administration and execution of the contract, both on and off site.
- (c) Major items of construction plant and equipment proposed for use in carrying out the Contract. Only reliable plant in good working order and suitable for the work required of it shall be shown on this schedule. The tenderer will also indicate on this schedule when each item will be available on the Works. Included also should be a schedule of plant, equipment and material to be imported for the purpose of the Contract, giving details of make, type, origin and CIF value as appropriate.
- (d) Details of sub-contractors to whom it is proposed to sublet any portion of the Contract and for whom authority will be requested for such subletting in accordance with clause 4 of the Condition of Contract.
- (e) A draft Program of Works in the form of a bar chart and Schedule of Payment which shall form part of the Contract if the tender is accepted. Any change in the Program or Schedule shall be subjected to the approval of the Engineer.
- (f) Details of any current litigation or arbitration proceedings in which the tenderer is involved as one of the parties.

##### **2.3 Joint Ventures**

Tenders submitted by a joint venture of two or more firms as partners shall comply with the following requirements:-

- (a) The tender, and in case of a successful tender, the Form of Agreement, shall be signed so as to be legally binding on all partners
- (b) One of the partners shall be nominated as being in charge, and this authorization shall be evidenced by submitting a power of attorney signed by legally authorized signatories of all the partners

- (c) The partner in charge shall be authorized to incur liabilities and receive instructions for and on behalf of any and all partners of the joint venture and the entire execution of the Contract including payment shall be done exclusively with the partner in charge.
- (d) All partners of the joint venture shall be liable jointly and severally for the execution of the Contract in accordance with the Contract terms, and a relevant statement to this effect shall be included in the authorization mentioned under (b) above as well as in the Form of Tender and the Form of Agreement (in case of a successful tender)
- (e) A copy of the agreement entered into by the joint venture partners shall be submitted with the tender.

### **3. COST OF TENDERING**

- 3.1 The Tenderer shall bear all costs associated with the preparation and submission of his tender and the Employer will in no case be responsible or liable for those costs, regardless of the conduct or outcome of the tendering process.
- 3.2 The procuring entity shall allow the tenderer to view the tender document free of charge before purchase.

### **4. SITE VISIT**

- 4.1. The tenderer is advised to visit and examine the Site and its surroundings and obtain for himself on his own responsibility, all information that may be necessary for preparing the tender and entering into a contract. The costs of visiting the Site shall be the tenderer's own responsibility
- 4.2. The tenderer and any of his personnel or agents will be granted permission by the Employer to enter upon premises and lands for the purpose of such inspection, but only upon the express condition that the tenderer, his personnel or agents, will release and indemnify the Employer from and against all liability in respect of, and will be responsible for personal injury (whether fatal or otherwise), loss of or damage to property and any other loss, damage, costs and expenses however caused, which but for the exercise of such permission, would not have arisen.
- 4.3. The Employer shall organize a site visit at a date to be notified. A representative of the Employer will be available to meet the intending tenderers at the Site. Tenderers must provide their own transport. The representative will not be available at any other time for site inspection visits.

Each tenderer shall complete the Certificate of Tenderer's Visit to the Site, at the time of the organized site visit.

### **5 TENDER DOCUMENTS**

- 5.1 The Tender documents comprise the documents listed here below and should be read together with any Addenda issued in accordance with Clause 7 of these instructions to tenderers.
  - a. Form of Invitation for Tenders
  - b. Instructions to Tenderers
  - c. Form of Tender
  - d. Appendix to Form of Tender
  - e. Form of Tender Surety
  - f. Tender and Confidential Business Questionnaires
  - g. Schedules of Supplementary Information
  - h. General Conditions of Contract - Part I
  - i. Conditions of Particular Application - Part II
  - j. Specifications both General and Special
  - k. Bills of Quantities
  - l. Drawings
  - m. Declaration Form
- 5.2 The tenderer is expected to examine carefully all instructions, conditions, forms, terms, specifications and drawings in the tender documents. Failure to comply with the requirements for tender submission will be at the tenderer's own risk. Pursuant to clause 23 of Instructions to Tenderers, tenders which are not substantially responsive to the requirements of the tender documents will be rejected.
- 5.3 All recipients of the documents for the proposed Contract for the purpose of submitting a tender (whether they submit a tender or not) shall treat the details of the documents as "private and confidential".



## **6 INQUIRIES BY TENDERERS**

- 6.1 A tenderer making an inquiry relating to the tender document may notify the Employer in writing or at the Employer's mailing address indicated in the Invitation to Tender. The Employer will respond in writing to any request for clarification which he receives earlier than 7 days prior to the deadline for the submission of tenders. Written copies of the Employer's response (including the query but without identifying the source of the inquiry) will be sent to all prospective tenderers who have purchased the tender documents.
- 6.2 The procuring entity shall reply to any clarifications sought by the tenderer within 3 days of receiving the request to enable the tenderer to make timely submission of its tender.

## **7 AMENDMENT OF TENDER DOCUMENTS**

- 7.1 At any time prior to the deadline for submission of tenders the Employer may, for any reason, whether at his own initiative or in response to a clarification requested by a prospective tenderer, modify the tender documents by issuing Addenda.
- 7.2 Any Addendum will be notified in writing to all prospective tenderers who have purchased the tender documents and will be binding upon them.
- 7.3 In order to allow prospective tenderers reasonable time in which to take the Addendum into account in preparing their tenders, the Employer may, at his discretion, extend the deadline for the submission of tenders.

## **PREPARATION OF TENDERS**

### **8 Language of Tender**

- 8.1 The tender and all correspondence and documents relating to the tender exchanged between the tenderer and the Employer shall be written in the English language. For the purpose of interpretation of the tender, the English language shall prevail.

### **9 Documents Comprising the Tender**

- 9.1 The tender to be prepared by the tenderer shall comprise:
- i. the Form of Tender and Appendix thereto,
  - ii. a Tender Security
  - iii. the Priced Bills of Quantities and Schedules
  - iv. the information on eligibility and qualification
  - v. Any other materials required to be completed and submitted in accordance with the Instructions to Tenderers.

The Forms, Bills of Quantities and Schedules provided in the tender documents shall be used without exception (subject to extensions of the schedules in the same format and to the provisions of clause 13.2 regarding the alternative forms of Tender Surety).

### **10 Tender Prices**

- 10.1 All the insertions made by the tenderer shall be made in INK and the tenderer shall clearly form the figures. The relevant space in the Form of Tender and Bills of Quantities shall be completed accordingly without interlineations or erasures except those necessary to correct errors made by the tenderer in which case the erasures and interlineations shall be initialed by the person or persons signing the tender.
- 10.2 A price or rate shall be inserted by the tenderer for every item in the Bills of Quantities whether the quantities are stated or not. Items against which no rate or price is entered by the tenderer will not be paid for by the Employer when executed and shall be deemed covered by the rates for other items and prices in the Bills of Quantities.

The prices and unit rates in the Bills of Quantities are to be the full [all-inclusive] value of the Work described under the items, including all costs and expenses which may be necessary and all general risks, liabilities and obligations set forth or implied in the documents on which the tender is based. All duties, taxes and other levies payable by the Contractor under the Contract, or for any other cause prior to the deadline for submission of tenders, shall be included in the rates and prices and the total Tender Price submitted by the tenderer.

Each price or unit rate inserted in the Bills of Quantities should be a realistic estimate for completing the activity or activities described under that particular item and the tenderer is advised against inserting a price or rate against any item contrary to this instruction.

Every rate entered in the Bills of Quantities, whether or not such rate be associated with a quantity, shall form part of the Contract. The Employer shall have the right to call for any item of work contained in the Bills of Quantities, and such items of work to be paid for at the rate entered by the tenderer and it is the intention of the Employer to take full advantage of unbalanced low rates.

10.3 The tenderer shall furnish with his tender written confirmation from his suppliers or manufacturers of basic unit rates for the supply of items listed in the Conditions of Contract clause 70 where appropriate. The Employer may require the tenderer to justify such rates so obtained from the suppliers or manufacturers.

10.4 The rates and prices quoted by the tenderer are subject to adjustment during the performance of the Contract only in accordance with the Provisions of the Conditions of Contract. The tenderer shall complete the schedule of basic rates and shall submit with his tender such other supporting information as required under clause 70 of the Conditions of Contract Part II.

10.5 Contract price variations shall not be allowed within the first 12 months of the contract.

10.6 Where quantity contract variation is allowed, the variation shall not exceed 15% of the original contract quantity.

10.7 Price variation requests shall be processed by the procuring entity within 30 days of receiving the request.

## **11 Currencies of Tender and Payment**

11.1 Tenders shall be priced in Kenya Shillings and the tender sum shall be in Kenya Shillings.

## **12 TENDER VALIDITY**

12.1 The tender shall remain valid and open for acceptance for period of **90** days from the specified date of tender opening or from the extended date of tender opening (in accordance with clause 7.3 here above) whichever is the later.

12.2 In exceptional circumstances prior to expiry of the original tender validity period, the Employer may request the tenderer for a specified extension of the period of validity. The request and the responses thereto shall be made in writing or by cable, telex or facsimile. A tenderer may refuse the request without forfeiting his Tender Surety. A tenderer agreeing to the request will not be required nor permitted to modify his tender, but will be required to extend the validity of his Tender Surety correspondingly.

## **13 TENDER SECURITY**

13.1 The tenderer shall furnish as part of his tender, a Tender Security in the amount and form stated in the Appendix to Instructions to Tenderers.

13.2 The tender security shall not exceed 2 percent of the tender price.

13.3 The Tender Security shall be valid at least thirty (**30**) days beyond the tender validity period.

13.4 Any tender not accompanied by an acceptable Tender Surety will be rejected by the Employer as non-responsive.

13.5 The Tender Sureties of unsuccessful tenderers will be returned as promptly as possible as but not later than twenty eight (28) days after expiration of the tender validity period. The Tender Surety of the successful tenderer will be returned upon the tenderer executing the Contract and furnishing the required Performance Security.

13.6 The Tender Surety may be forfeited:

- a) if a tenderer withdraws his tender during the period of tender validity: or
- b) in the case of a successful tenderer, if he fails, within the specified time limit
  - i. to sign the Agreement, or
  - ii. to furnish the necessary Performance Security
- c) If a tenderer does not accept the correction of his tender price pursuant to clause 24.

## **14 NO ALTERNATIVE OFFERS**

14.1 The tenderer shall submit an offer which complies fully with the requirements of the tender documents unless otherwise provided for in the appendix.

Only one tender may be submitted by each tenderer either by himself or as partner in a joint venture. A tenderer who submits more than one bid per tender will be disqualified.

- 14.2 The tenderer shall not attach any conditions of his own to his tender. The tender price must be based on the tender documents. The tenderer is not required to present alternative construction options and he shall use without exception, the Bills of Quantities as provided, with the amendments as notified in tender notices, if any, for the calculation of his tender price. Any tenderer who fails to comply with this clause will be disqualified.

## **15 PRE-TENDER MEETING**

- 15.1 If a pre-tender meeting is convened, the tenderer's designated representative is invited to attend at the venue and time in the Invitation to Tender. The purpose of the meeting will be to clarify issues and to answer questions on any matter that may be raised at that stage.
- 15.2 The tenderer is requested as far as possible to submit any questions in writing to reach the Employer not later than seven (7) days before the meeting. It may not be practicable at the meeting to answer questions received late, but questions and responses will be transmitted in accordance with the following:
- (a) Minutes of the meeting, including the text of the questions raised and the responses given together with any responses prepared after the meeting will be transmitted without delay to all purchasers of the tender documents. Any modification of the tender documents listed in – Clause 9 which may become necessary as a result of the pre-tender meeting shall be made by the Employer exclusively through the issue of a tender notice pursuant to Clause 7 and not through the minutes of the pre-tender meeting.
  - (b) Non-attendance at the pre-bid meeting will not be cause for disqualification of a bidder.

## **16 FORMAT AND SIGNING OF TENDERS**

- 16.1 The tenderer shall prepare his tender as outlined in clause 9 above and mark appropriately one set "ORIGINAL" and the other "COPY".
- 16.2 The copy of the tender and Bills of Quantities shall be typed or written in indelible ink and shall be signed by a person or persons duly authorized to sign on behalf of the tenderer. All pages of the tender where amendments have been made shall be initialed by the person or persons signing the tender.
- 16.3 The complete tender shall be without alterations, interlineations or erasures, except as necessary to correct errors made by the tenderer, in which case such corrections shall be initialed by the person or persons signing the tender.

## **SUBMISSION OF TENDERS**

### **17 Sealing and Marking of Tenders**

- 17.1 The tenderer shall seal the original and copy of the tender in separate envelopes, duly marking the envelopes as "ORIGINAL" and "COPY". The envelopes shall then be sealed in an outer separate envelope.
- 17.2 The inner and outer envelopes shall be addressed to the Employer at the address stated in the Appendix to Instructions to Tenderers and bear the name and identification of the Contract stated in the said Appendix with a warning not to open before the date and time for opening of tenders stated in the said Appendix.
- 17.3 The inner envelopes shall each indicate the name and address of the tenderer to enable the tender to be returned unopened in case it is declared "late", while the outer envelope shall bear no mark indicating the identity of the tenderer.
- 17.4 If the outer envelope is not sealed and marked as instructed above, the Employer will assume no responsibility for the misplacement or premature opening of the tender. A tender opened prematurely for this cause will be rejected by the Employer and returned to the tenderer.

### **18 Deadline for Submission of Tenders**

- 18.1 Tenders must be received by the Employer at the address specified in Clause 17.2 and on the date and time specified in the Letter of Invitation, subject to the provisions of clause 7.3, 18.2 and 18.3.

Tenders delivered by hand must be placed in the "tender box" provided in the office of the Employer.

Proof of posting will not be accepted as proof of delivery and any tender delivered after the above stipulated time, from whatever cause arising will not be considered.

- 18.2 The Employer may, at his discretion, extend the deadline for the submission of tenders through the issue of an Addendum in accordance with clause 7, in which case all rights and obligations of the Employer and the tenderers previously subject to the original deadline shall thereafter be subject to the new deadline as extended.

- 18.3 Any tender received by the Employer after the prescribed deadline for submission of tender will be returned unopened to the tenderer.

## **19 Modification and Withdrawal of Tenders**

- 19.1 The tenderer may modify or withdraw his tender after tender submission, provided that written notice of the modification or withdrawal is received by the Employer prior to the prescribed deadline for submission of tenders.

- 19.2 The tenderer's modification or withdrawal notice shall be prepared, sealed, marked and dispatched in accordance with the provisions for the submission of tenders, with the inner and outer envelopes additionally marked "MODIFICATION" or "WITHDRAWAL" as appropriate.

- 19.3 No tender may be modified subsequent to the deadline for submission of tenders.

- 19.4 No tender may be withdrawn in the interval between the deadline for submission of tenders and the period of tender validity specified on the tender form. Withdrawal of a tender during this interval will result in the forfeiture of the Tender Surety.

- 19.5 Subsequent to the expiration of the period of tender validity prescribed by the Employer, and the tenderer having not been notified by the Employer of the award of the Contract or the tenderer does not intend to conform with the request of the Employer to extend the period of tender validity, the tenderer may withdraw his tender without risk of forfeiture of the Tender Surety.

## **TENDER OPENING AND EVALUATION**

### **20 TENDER OPENING**

- 20.1 The Employer will open the tenders in the presence of the tenderers' representatives who choose to attend at the time and location indicated in the Letter of Invitation to Tender. The tenderers' representatives who are present shall sign a register evidencing their attendance.

- 20.2 Tenders for which an acceptable notice of withdrawal has been submitted, pursuant to clause 19, will not be opened. The Employer will examine the tenders to determine whether they are complete, whether the requisite Tender Sureties have been furnished, whether the documents have been properly signed and whether the tenders are generally in order.

- 20.3 At the tender opening, the Employer will announce the tenderer's names, total tender price, tender price modifications and tender withdrawals, if any, the presence of the requisite Tender Surety and such other details as the Employer, at his discretion, may consider appropriate. No tender shall be rejected at the tender opening except for late tenders.

- 20.4 The Employer shall prepare minutes of the tender opening including the information disclosed to those present.

- 20.5 Tenders not opened and read out at the tender opening shall not be considered further for evaluation, irrespective of the circumstances.

### **21 PROCESS TO BE CONFIDENTIAL**

- 21.1 After the public opening of tenders, information relating to the examination, clarification, evaluation and comparisons of tenders and recommendations concerning the award of Contract shall not be

disclosed to tenderers or other persons not officially concerned with such process until the award of Contract is announced.

- 21.2 Any effort by a tenderer to influence the Employer in the process of examination, evaluation and comparison of tenders and decisions concerning award of Contract may result in the rejection of the tenderer's tender.

## **22 CLARIFICATION OF TENDERS**

- 22.1 To assist in the examination, evaluation and comparison of tenders, the Employer may ask tenderers individually for clarification of their tenders, including breakdown of unit prices. The request for clarification and the response shall be in writing, but no change in the price or substance of the tender shall be sought, offered or permitted except as required to confirm the correction of arithmetical errors discovered by the employer during the evaluation of the tenders in accordance with clause 24.
- 22.2 No tenderer shall contact the Employer on any matter relating to his tender from the time of the tender opening to the time the Contract is awarded. If the tenderer wishes to bring additional information to the notice of the Employer, he shall do so in writing.

## **23 DETERMINATION OF RESPONSIVENESS**

- 23.1 Prior to the detailed evaluation of tenders, the Employer will determine whether each tender is substantially responsive to the requirements of the tender documents.
- 23.2 For the purpose of this clause, a substantially responsive tender is one which conforms to all the terms, conditions and specifications of the tender documents without material deviation or reservation. A material deviation or reservation is one which affects in any substantial way the scope, quality, completion timing or administration of the Works to be undertaken by the tenderer under the Contract, or which limits in any substantial way, inconsistent with the tender documents, the Employer's rights or the tenderers obligations under the Contract and the rectification of which would affect unfairly the competitive position of other tenderers who have presented substantially responsive tenders.
- 23.3 Each price or unit rate inserted in the Bills of Quantities shall be a realistic estimate of the cost of completing the works described under the particular item including allowance for overheads, profits and the like. Should a tender be seriously unbalanced in relation to the Employer's estimate of the works to be performed under any item or groups of items, the tender shall be deemed not responsive.
- 23.4 A tender determined to be not substantially responsive will be rejected by the Employer and may not subsequently be made responsive by the tenderer by correction of the non-conforming deviation or reservation.

## **24 CORRECTION OF ERRORS**

Tenders determined to be substantially responsive shall be checked by the Employer for any arithmetic errors in the computations and summations. Subject to section 79(2)(b) of the Act, any errors in the submitted tender arising from a miscalculation of unit price, quantity, subtotal and total bid price shall be considered as a major deviation that affects the substance of the tender and shall lead to disqualification of the tender as non-responsive

## **25 CONVERSION TO SINGLE CURRENCY**

- 25.1 For compensation of tenders, the tender price shall first be broken down into the respective amounts payable in various currencies by using the selling rate or rates of the Central Bank of Kenya ruling on the date twenty one (21) days before the final date for the submission of tenders.
- 25.2 The Employer will convert the amounts in various currencies in which the tender is payable (excluding provisional sums but including Day works where priced competitively) to Kenya Shillings at the selling rates stated in clause 25.1.

## **26 EVALUATION AND COMPARISON OF TENDERS**

- 26.1 The Employer will evaluate only tenders determined to be substantially responsive to the requirements of the tender documents in accordance with clause 23.

- 26.2 In evaluating tenders, the Employer will determine for each tender the evaluated tender price by adjusting the tender price as follows:
- (a) Making any correction for errors pursuant to clause 24.
  - (b) Excluding Provisional Sums and provision, if any, for Contingencies in the Bills of Quantities, but including Day works where priced competitively.
- 26.3 The Employer reserves the right to accept any variation, deviation or alternative offer. Variations, deviations, alternative offers and other factors which are in excess of the requirements of the tender documents or otherwise result in the accrual of unsolicited benefits to the Employer, shall not be taken into account in tender evaluation.
- 26.4 Price adjustment provisions in the Conditions of Contract applied over the period of execution of the Contract shall not be taken into account in tender evaluation.
- 26.5 If the lowest evaluated tender is seriously unbalanced or front loaded in relation to the Employer's estimate of the items of work to be performed under the Contract, the Employer may require the tenderer to produce detailed price analyses for any or all items of the Bills of Quantities, to demonstrate the relationship between those prices, proposed construction methods and schedules. After evaluation of the price analyses, the Employer may require that the amount of the Performance Security set forth in clause 29 be increased at the expense of the successful tenderer to a level sufficient to protect the Employer against financial loss in the event of subsequent default of the successful tenderer under the Contract.
- 26.6 The procuring entity may at any time terminate procurement proceedings before contract award and shall not be liable to any person for the termination.
- 26.7 The procuring entity shall give prompt notice of the termination to the tenderers and on request give its reasons for termination within 14 days of receiving the request from any tenderer.
- 26.8 A tenderer who gives false information in the tender document about its qualification or who refuses to enter into a contract after notification of contract award shall be considered for debarment from participating in future public procurement.

## 27 **AWARD OF CONTRACT**

- 27.1 Subject to Sub-clause 27.2, the Employer will award the Contract to the tenderer whose tender is determined to be substantially responsive to the tender documents and who has offered the lowest evaluated tender price subject to possessing the capability and resources to effectively carry out the Contract Works as required in Sub-clause 2.1 and 2.2 here above.
- 27.2 The Employer reserves the right to accept or reject any tender, and to annul the tendering process and reject all tenders, at any time prior to award of Contract, without thereby incurring any liability to the affected tenderers or any obligation to inform the affected tenderers of the grounds for the Employer's action.

## 28 **NOTIFICATION OF AWARD**

- 28.1 Prior to the expiration of the period of tender validity prescribed by the Employer, the Employer will notify the successful tenderer by cable, telefax or telex and confirmed in writing by registered letter that his tender has been accepted. This letter (hereinafter and in all Contract documents called "Letter of Acceptance") shall name the sum (hereinafter and in all Contract documents called "the Contract Price") which the Employer will pay to the Contractor in consideration of the execution and completion of the Works as prescribed by the Contract.
- 28.2 At the same time that the Employer notifies the successful tenderer that his tender has been accepted, the Employer shall notify the other tenderers that the tenders have been unsuccessful.
- 28.3 Within fourteen [14] days of receipt of the Form of Contract Agreement from the Employer, the successful tenderer shall sign the form and return it to the Employer together with the required Performance Security.
- 28.4 The parties to the contract shall have it signed within 30 days from the date of notification of contract award unless there is an administrative review request.

29 **PERFORMANCE GUARANTEE**

- 29.1 Within fourteen [14] days of receipt of the notification of award from the Employer, the successful tenderer shall furnish the Employer with a Performance Security in the amount stated in the Appendix to Instructions to Tenderers and in the format stipulated in the Conditions of Contract.
- 29.2 The Performance Security to be provided by the successful tenderer shall be an unconditional Bank Guarantee issued at the tenderer's option by a reputable Bank approved by the Employer and located in the Republic of Kenya and shall be divided into two elements namely, a performance security payable in foreign currencies (based upon the exchange rates determined in accordance with clause 60(5) of the Conditions of Contract) and a performance security payable in Kenya Shillings. The value of the two securities shall be in the same proportions of foreign and local currencies as requested in the form of foreign currency requirements.
- 29.3 Failure of the successful tenderer to lodge the required Performance Security shall constitute a breach of Contract and sufficient grounds for the annulment of the award and forfeiture of the Tender Security and any other remedy under the Contract. The Employer may award the Contract to the next ranked tenderer.

30 **ADVANCE PAYMENT**

An advance payment, if allowed by the Employer, shall be made under the Contract, if requested by the Contractor, in accordance with clause 60(1) of the Conditions of Contract. The Advance Payment Guarantee shall be denominated in the proportion and currencies named in the form of foreign currency requirements. For each currency, a separate guarantee shall be issued. The guarantee shall be issued by a Bank located in the Republic of Kenya, or a foreign Bank through a correspondent Bank located in the Republic of Kenya, in either case subject to the approval of the Employer.

31 **CORRUPT OR FRAUDULENT PRACTICES**

- 31.1 The procuring entity requires that tenderers observe the highest standard of ethics during the procurement process and execution of contracts. A tenderer shall sign a declaration that he has not and will not be involved in corrupt or fraudulent practices.

**APPENDIX TO INSTRUCTIONS TO TENDERERS**

**Notes on the Appendix to Instructions to Tenderers**

The following appendix to instructions to tenderers shall complement or amend the provisions of the instructions to tenderers (Section II). Wherever there is a conflict between the provisions of the instructions to tenderers and the provisions of the appendix, the provisions of the appendix herein shall prevail over those of the instructions to tenderers.

**CLAUSE 2: ELIGIBILITY REQUIREMENTS**

**1. PRELIMINARY EVALUATION (MANDATORY REQUIREMENTS)**

**2. TECHNICAL EVALUATION**

Qualification Criteria			Compliance Requirements
No.	Subject	Requirement	
<b>1</b>	<b>Historical Contract Non-Performance</b>		
1.1	History of Non-Performing Contracts	Non-performance of a contract did not occur within the last Three (3) years prior to the deadline for application submission based on all information on fully settled disputes or litigation. A fully settled dispute or litigation is one that has been resolved in accordance with the Dispute Resolution Mechanism under the respective contract, and where all appeal instances available to the applicant have been exhausted.	Must Meet Requirement
1.2	Pending Litigation	All pending litigation shall in total not represent more than fifty percent (50%) of the Applicant's net worth and shall be treated as resolved against the Applicant.  Attach an affidavit from Commissioner of Oaths.	Must Meet Requirement
<b>2</b>	<b>Financial Situation</b>		
2.1	Financial Performance	Provide Audited Accounts for the last two (2) years to demonstrate capacity to have a cash flow amount of minimum Kshs.500,000 equivalent working capital	Must Meet Requirement
	Average annual construction turnover	Minimum average annual construction turnover of Kshs. One million (1,000,000) calculated as total certified payments received for contracts in progress or completed within the last three (3) years	Must Meet Requirement
<b>3.0</b>	<b>Past Experience</b>	Participation as contractor, management contractor or subcontractor, in at least two (2) contracts within the last five (5) years, each with a value of at least Kshs. 1,000,000 (One Million), that have been successfully and substantially completed and that are similar to the proposed works. The similarity shall be based on the physical size, complexity, methods/technology or other characteristics as described in Scope of Works	Must Meet Requirement
<b>4.0</b>	Work Methodology	Submission of a brief work methodology in sufficient detail to demonstrate the adequacy of bidder's proposals to meet the technical specifications and the completion time.  Proposed resourced work programme	Must Meet Requirement
<b>5. Current Commitments</b>			
	On-going contracts	The total value of outstanding works for the on-going contracts must not exceed Kshs. Ten Million (10,000,000.00)	Must Meet Requirements

<b>6. Site Staff</b>	a)Site Agent	The Site staff shall possess minimum qualification levels as set below; a) Qualifications - Diploma in Civil Engineering  a) General Experience = 6 years b) Specific Experience = 4 Years	Must Meet Requirement
----------------------	--------------	--	-----------------------



	b) Foreman	a) Qualifications - Cert. in Civil Engineering/KIHBT b) General Experience = 4 years c) Specific Experience = 2 Years	Must Meet Requirement

**EQUIPMENT HOLDING - APPENDIX 1**

No	Category of Registration (Class)	Minimum Equipment Required	Mandatory Minimum Number of Equipment Required
8	NCA 8 & Above	The bidder MUST indicate and provide proof of ownership or leasing of at least Two different core Plant/ Equipment necessary for undertaking the project to completion within the completion time. Motor Grader Excavator Water Bowser Tipper-2No Single Drum Roller Concrete Mixer Porker Vibrator	Must meet requirement
<p><b>Note: Submit Evidence of Ownership/Leasing (Mandatory)</b> : Anyone who submits fake logbook(s)/lease agreement(s) shall have their names forwarded to Public Procurement Oversight Authority (PPOA) for Debarment/Blacklisting.</p>			

## SECTION III

### CONDITIONS OF CONTRACT, PART I - GENERAL CONDITIONS OF CONTRACT

The Conditions of Contract, Part I - General Conditions, shall be those forming Part I of the "Conditions of Contract for works of Civil Engineering Construction, Fourth Edition 1987, re-printed in 1992 with further amendments, prepared by the Federation Internationale des Ingenieurs - conseils (FIDIC). The Conditions are subject to variations and additions set out in Part II hereof entitled "Conditions of Contract, Part II - Conditions of Particular Application".

#### **Note**

- i. The standard text of the General Conditions of Contract must be retained intact to facilitate its reading and interpretation by tenderers. Any amendments and additions to the General Conditions, specific to a given Contract, should be introduced in the Conditions of Particular Application or in the Appendix to Form of Tender.
- ii. The Conditions of Particular Application take precedence over the General Conditions of Contract.
- iii. Copies of the FIDIC Conditions of Contract can be obtained from:  
FIDIC Secretariat  
P.O. Box 86  
1000 Lausanne 12  
*Switzerland*  
Fax: 41 21 653 5432  
Telephone: 41 21 653 5003

**SECTION IV  
CONDITIONS OF CONTRACT PART II  
(CONDITIONS OF PARTICULAR APPLICATION)**

**GENERAL**

The following Conditions of Particular Application shall supplement the General Conditions of Contract. Whenever there is a conflict, the provisions herein shall prevail over those in the General Conditions of Contract. The Particular Condition is preceded by the corresponding clause number of the General Conditions to which it relates.

## **CONDITIONS OF CONTRACT PART II**

### **(CONDITIONS OF PARTICULAR APPLICATION)**

#### **Sub-Clause 1.1: Definitions and Interpretation**

- 1.1 (a) (i) The “Employer” is the Kenya Rural Roads Authority, represented by the Director General.
- 1.1 (a) (iv) The “Engineer” is the General Manager – Maintenance, Kenya Rural Roads Authority.

Add the following at the end of the sub-clause:

- 1.1 (h) (i) “Materials” means materials intended to form or forming part of the Permanent Works.

#### **SUB-CLAUSE 5.1: LANGUAGE AND LAW**

- (a) The Contract document shall be drawn up in the ENGLISH LANGUAGE. Communication between the Contractor and the Engineer’s Representative shall be in this given language.
- (b) The Laws applicable to this Contract shall be the Laws of the Republic of Kenya.

#### **SUB-CLAUSE 5.2: PRIORITY OF CONTRACT DOCUMENTS**

*Delete the documents listed 1-6 and substitute:*

- (1) The Contract Agreement (if completed)
- (2) The Letter Of Acceptance;
- (3) The Tender and Appendix to Tender;
- (4) The Conditions of Contract Part II;
- (5) The Conditions of Contract Part I;
- (6) The Special Specifications;
- (7) The Standard Specification for Road and Bridge Construction, 1986;
- (8) The Drawings;
- (9) The priced Schedule of Rates

#### **SUB-CLAUSE10.1: PERFORMANCE SECURITY**

- (a) The Contractor shall provide security for his proper Performance of the Contract within 30 days (thirty) after receipt of the Letter of Acceptance from the Employer.
- (b) The Performance Security shall be in the form of unconditional Bank Guarantee issued by a bank incorporated in Kenya.
- (c) The amount of Performance Security shall be 5% of the contract price.

#### **SUB-CLAUSE10.2: VALIDITY OF PERFORMANCE SECURITY**

The Performance Security shall be valid until the date 28 days after the date of issue of the Defects Liability Certificate. The security shall be returned to the Contractor within 14 days after issuance of the Defects Liability Certificate.

#### **SUB-CLAUSE10.3: CLAIMS UNDER PERFORMANCE SECURITY**

Delete the entire sub-Clause 10.3

## **SUB-CLAUSE 11.2: ACCESS TO DATA**

Data made available by the Employer in accordance with Clause 11.1 shall be deemed to include data listed elsewhere in the Contract as open for inspection at the address stipulated in the Appendix to Tender.

## **SUB-CLAUSE 14.1: PROGRAM TO BE SUBMITTED**

The time within which the program shall be submitted shall be as specified in the Appendix to the Form of Tender.

The program submitted by the Contractor as part of his tender, where this was required, and shall in no material manner deviate from the said program.

The program shall be in the form of a Critical Path Method Network (CPM Network) showing the order of procedure and a description of the construction methods and arrangements by which the Contractor proposes to carry out the works. It should also be supplemented by a time -bar chart of the same program. The program shall be coordinated with climatic, groundwater and other conditions to provide for completion of the works in the order and by the time specified. The program shall be revised at three-month intervals and should include a chart of the principle quantities of work forecast for execution monthly.

The Contractor shall submit to the Engineer not later than the day or date mentioned in the Appendix to the Form of Tender, a general description of his proposed arrangements and methods for the execution of the works, including temporary offices, buildings, access roads, construction plant and its intended production output, working shift arrangements, labour strength, skilled and unskilled, supervision arrangements, power supply arrangements, supply of materials including a materials utilization program and storage, cement handling, concrete mixing and handling, methods of excavation, dealing with water, testing methods and facilities.

During the execution of the works, the Contractor shall submit to the Engineer full and detailed particulars of any proposed amendments to the arrangements and methods submitted in accordance with the foregoing.

If details of the Contractors proposals for Temporary Works are required by the Engineer for his own information the Contractor shall submit such details within fourteen days of being requested to do so.

The various operations pertaining to the works shall be carried out in such a progressive sequence as will achieve a continuous and consecutive output of fully completed road works inclusive of all bridge works and culverts within the time limits specified in the Contract. Generally the Contractor shall start at one end of the road and progress continuously towards the other without leaving any isolated section or sections of uncompleted road provided always that the site of the works has been acquired in its entirety and the encumbrances and services thereon removed.

The Contractor shall allow in his programme for the following public holidays per calendar year during which the Contractor shall not be permitted to work:

- New Year's Day (1<sup>st</sup> January)
- Good Friday
- Easter Monday
- Labour Day (1<sup>st</sup> May)
- Madaraka Day (1<sup>st</sup> June)
- Idd Ul Fitr
- Mashujaa Day (20<sup>th</sup> October)
- Jamhuri Day (12<sup>th</sup> December)
- Christmas Day (25<sup>th</sup> December)
- Boxing Day (26<sup>th</sup> December)

The Contractor shall also allow per calendar year for a further 2 unspecified public holidays which may be announced by the Government of Kenya with no prior notification upon which he shall not be permitted to work.

### **SUB-CLAUSE 14.3: CASH FLOW ESTIMATE**

The time within which the detailed cash flow estimate shall be submitted shall be as specified in the Appendix to the Form of Tender.

### **SUB-CLAUSE 15.1: CONTRACTOR'S SUPERINTENDENCE**

The Contractor shall, within seven (7) days of receipt of the Engineer's order to commence the works inform the Engineer in writing the name of the Contractor's Representative and the anticipated date of his arrival on site.

The contractor's Representative or agent shall be an Engineer with the Engineer's Board of Kenya in accordance with Chapter 530 of the Laws of Kenya or have equivalent status approved by the Board, able to read and write English fluently, and, shall have at least 10 years working experience as an Engineer.

### **SUB-CLAUSE 16.2: ENGINEER AT LIBERTY TO OBJECT**

At the end of this Clause add:

"by a competent substitute approved by the Engineer and at the Contractors own expense."

Add the following Sub-Clauses 16.3 and 16.4:

### **SUB-CLAUSE 16.3: QUALIFICATION AND LANGUAGE ABILITY OF SUPERINTENDING STAFF**

*The Contractor's superintending staff shall meet the following minimum qualifications:*

- a) Should have a working knowledge of English or Kiswahili.
- b) Must have the following certificates from the Approved Technical Institutions approved by the Engineer.
  - Site Agent – Diploma
  - Foremen – Certificate
- c) Must have the following minimum experience:
  - Site Agent – 4 years
  - Foremen – 2 years
- c) Qualifications as above shall be subject to verification and approval on site by the Engineer or his representative on site before commencement of the said works.

### **SUB-CLAUSE 16.4: EMPLOYMENT OF LOCAL PERSONNEL**

The Contractor is encouraged, to the extent practicable and reasonable, to employ staff and labour with appropriate qualifications and experience who are Kenya citizens.

### **SUB-CLAUSE 19.1: SAFETY, SECURITY AND PROTECTION OF THE ENVIRONMENT**

Add Sub-Clause-paragraph (d) to Sub-Clause 19.1 as follows:

Notwithstanding the Contractor's obligation under Sub-Clause-paragraph (a), (b) and 9(c) of Sub-Clause 19.1 of the Conditions of Contract, the Contractor shall observe the following measures with a view to reducing or elimination adverse environmental effects by the site works:

- (i) All quarries and borrow pits shall be filled and landscaped to their original state after extraction of construction material
- (ii) Soil erosion due to surface runoff or water from culverts or other drainage structures should be avoided by putting in place proper erosion control measures that shall include, but are not limited to grassing and planting of trees.

- (iii) Spillage of oils, fuels and lubricants shall be avoided and if spilt, shall be collected and disposed off in such a way as not to adversely affect the environment

**SUB-CLAUSE 20.4: EMPLOYERS RISKS**

Delete Sub-Clause (h) and substitute with;

- (h) Any operation of the forces of nature (insofar as it occurs on site) which an experienced contractor:
  - (i) Could not have reasonably foreseen, or
  - (ii) Could reasonably have foreseen, but against which he could not reasonably have taken at least one of the following measures:
    - A. Prevent loss or damage to physical property from occurring by taking appropriate measures or
    - B. Insure against such loss or damage.

**SUB-CLAUSE 21.1: INSURANCE OF WORKS AND CONTRACTORS' EQUIPMENT**

"It being understood that such insurance shall provide for compensation to be payable in the types and proportions of currencies required to rectify the loss or damage incurred"

Delete the first sentence of this Clause and replace with the following:

"prior to commencement of the Works the Contractor shall, without limiting his or the Employer's obligations and responsibilities under Clause 20, insure to the satisfaction of the Employer:"

**SUB-CLAUSE 21.2: SCOPE OF COVER**

Amend sub-paragraph (a) of Sub-Clause 21.2 as follows:

Delete words "from the start of work at the site" and substitute the words "from the first working day after the Commencement Date"

Add the following as Sub-Clause (c) under Sub-Clause-Clause 21.2:

(c) It shall be the responsibility of the Contractor to notify the insurance company of any change in the nature and extent of the Works and to ensure the adequacy of the insurance coverage at all times during the period of the Contract.

**SUB-CLAUSE 21.4: EXCLUSIONS**

Amend Sub-Clause 21.4 to read as follows:

"There shall be no obligation for the insurances in Sub-Clause 21.1 to include loss or damage caused by the risks listed under Sub-Clause 20.4 sub-paragraph (a) (i) to(iv) of the Conditions of Particular Application."

**SUB-CLAUSE 23.2: MINIMUM AMOUNT OF INSURANCE**

Add the following at the end of this Clause:

"with no limits to the number of occurrences".

**SUB-CLAUSE 25.1: EVIDENCES AND TERMS OF INSURANCE**

Amend Sub-Clause 25.1 as follows:

Insert the words "as soon as practicable after the respective insurances have been taken out but in any case" before the words "prior to the start of work at the site"

Add the following Sub-Clauses 25.6, 25.7

#### **SUB-CLAUSE 25.6: INSURANCE NOTICES**

Each policy of insurance effected by the Contractor for purposes of the Contract shall include a provision to the effect that the Insurer shall have a duty to give notice in writing to the Contractor and Employer of the date when a premium becomes payable. This shall not be more than thirty (30) days before that date and the policy shall remain in force until thirty (30) days after the giving of such notice.

#### **SUB-CLAUSE 25.7: NOTIFICATION TO INSURERS**

It shall be the responsibility of the Contractor to notify insurers under any of the insurance referred to in the preceding clauses 21, 23 and 24 on any matter or event which by the terms of such insurance are required to be so notified. The Contractor shall indemnify and keep indemnified the Employer against all losses, claims, demands, proceedings, costs, charges and expenses whatsoever arising out of or in consequence of any default by the Contractor in complying with the requirements of this Sub-Clause whether as a result of avoidance of such insurance or otherwise.

#### **SUB-CLAUSE 28.2: ROYALTIES**

Add at the end of this Sub-Clause the following sentence:

“The Contractor shall also be liable for all payments or compensation if any that are levied in connection with the dumping of part or all of any such material.”

#### **SUB-CLAUSE 29.1: INTERFERENCE WITH TRAFFIC**

Supplement Sub-Clause 29.1 by adding the following sentence at the end:

“The Contractor will be permitted to use existing public roads for access to the site. The Contractor shall pay vehicle license tax and road maintenance duty in accordance with relevant regulations and shall obtain any necessary permits or licenses from relevant authorities for transporting his equipment.”

#### **SUB-CLAUSE 29.2: - REINSTATEMENT AND COMPENSATION FOR DAMAGES TO PERSONS AND PROPERTY**

The Contractor shall reinstate all properties whether public or private which are damaged in consequence of the construction and, maintenance of the works to a condition as specified and at least equal to that prevailing before his first entry on them.

If in the opinion of the Engineer the Contractor shall have failed to take reasonable and prompt action to discharge his obligations in the matter of reinstatement, the Engineer will inform the Contractor in writing of his opinion, in which circumstances the Employer reserves the right to employ others to do the necessary work of reinstatement and to deduct the cost thereof from any money due or which shall become due to the Contractor.

The Contractor shall refer to the Employer without delay all claims which may be considered to fall within the provisions of Clause 22.1.

#### **CLAUSE 34: LABOUR**

Add the following Sub-Clauses 34.2 to 34.8

#### **SUB-CLAUSE 34.2: CONDITIONS OF EMPLOYMENT OF LABOUR**

The Contractor shall be responsible for making all arrangements for and shall bear all costs relating to recruitment, or other official permission for movements of staff and labour.

#### **SUB-CLAUSE 34.3: WORKING CONDITIONS & FAIR WAGES**

The Contractor shall, in respect of all persons employed anywhere by him in the execution of the Contract, and further in respect of all persons employed by him otherwise than in the execution of the Contract in every factory, Workshop or place occupied or used by him for the execution of the Contract, observe and fulfill the following conditions:



- a. The Contractor shall pay rates of wages, observe hours of labour and provide conditions of labour, housing, amenities and facilities not less favourable than those required by the Regulation of Wages (Building and Construction Industry) Order 2004, and subsequent amendments thereto, or in any wage scales, hours of work or conditions agreed by the Ministry of Labour or other Government Department in consultation with the appropriate wage fixing authority and generally recognized by other employees in the district whose general circumstances in the trade or industry in which the Contractor is engaged are similar.
- (b) The Contractor shall recognize the freedom of his employees to be members of trade unions.
- (c) The Contractor shall maintain records in English of the time worked by, and the wages paid to, his employees. The Contractor shall furnish to the Engineer or Employer, if called upon to do so, such particulars of the rates, wages and conditions of labour as the Employer or Engineer may direct.
- (d) The Contractor shall be responsible for the observance of this clause by sub-Contractors employed in the execution of the works.

**SUB-CLAUSE 34.4: BREACH OF FAIR WAGES CLAUSE**

Any Contractor or Sub-Contractor who is found to be in breach of Fair Wages Clause shall cease to be approved as a Contractor or Sub-Contractor for such period as the Cabinet Secretary of the Ministry responsible for Roads determine through the National Construction Authority.

Should a claim be made to the Employer alleging the Contractor's default in payment of Fair Wages of any workman employed on the Contract and if proof thereof satisfactory to the Employer is furnished by the Labour Authority, the Employer may, failing payment by the Contractor, pay the claims out of any monies due or which may become due to the Contractor under the Contract.

**SUB-CLAUSE 34.5: RECRUITMENT OF UNSKILLED LABOUR**

Any additional unskilled labour which is required by the Contractor for the works and which is not in his employ at the time of the award of the contract shall be recruited by the Contractor from the Labour Exchange or Exchange or Exchanges nearest to the site or sites of the work.

**SUB-CLAUSE 34.6: COMPENSATION FOR INJURY**

The Contractor shall in accordance with the Workmen's Compensation Act Of the Laws Of Kenya and any other regulations in force from time to time pay compensation for loss or damage suffered in consequence of any accident or injury or disease resulting from his work to any workman or other person in the employment of the Contractor or any Subcontractor.

**SUB-CLAUSE 34.7: LABOUR STANDARDS**

The Contractor shall comply with the existing local labour laws, regulations and labour standards

The Contractor shall formulate and enforce an adequate safety program with respect to all work under his contract, whether performed by the Contractor or subcontractor. The Contractor has assurance from the Employer of cooperation where the implementation of these safety measures requires joint cooperation.

Upon written request of the Employer the Contractor shall remove or replace any of his employees employed under this Contract.

Add the following Sub-Clause 35.2 and 35.3.

**SUB-CLAUSE 35.2: RECORDS OF SAFETY AND HEALTH**

The Contractor shall maintain such records and make such reports concerning safety, health and welfare of persons and damage to property as the Engineer may from time to time prescribe.

**SUB-CLAUSE 35.3: REPORTING OF ACCIDENTS**

The Contractor shall report to the Engineer details of any accident as soon as possible after its occurrence. In the case of any fatality or serious accident, the Contractor shall, notify the Engineer immediately by the quickest available means. The Contractor shall also notify the relevant authority whenever the Laws of Kenya require such a report.

#### **SUB-CLAUSE 41.1: COMMENCEMENT OF WORKS**

Amend Sub-Clause 41.1 as follows:

Delete the words “as soon as is reasonably possible” in the first sentence and replace with “within the period stated in the Appendix to Tender”.

#### **SUB-CLAUSE 43.1: TIME FOR COMPLETION**

Amend Sub-Clause 43.1 as follows:

Delete the words “within the time” to “such extended time” and substitute “by the date or dates stated or implied in Clause 14 of these Conditions of Particular Application.

#### **SUB-CLAUSE 44.1: EXTENSION OF TIME FOR COMPLETION**

Add at the end of Sub-Clause 44.1 the following:

“Neither rains falling within the rainy seasons as occurs in Kenya nor floods caused by such rains shall be deemed exceptional weather conditions such as may fairly entitle the Contractor to an extension of time for the completion of the work.”

#### **SUB-CLAUSE 45.1: RESTRICTION ON WORKING HOURS**

Add at the end of Sub-Clause 45.1 the following:

“If the Contractor requests permission to work by night as well as by day, then if the Engineer shall grant such permission the Contractor shall not be entitled to any additional payments for so doing. All such work at night shall be carried out without unreasonable noise or other disturbance and the Contractor shall indemnify the Employer from and against any liability for damages on account of noise or other disturbance created while or in carrying out night work and from and against all claims, demands, proceedings, costs, charges and expenses whatsoever in regard or in relation to such liability.

“In addition the Contractor will be required to provide, for any work carried out at night or recognized days of rest, adequate lighting and other facilities so that the work is carried out safely and properly.

“In the event of the Engineer granting permission to the Contractor to work double or rotary shifts or on Sundays, the Contractor shall be required to meet any additional costs to the Employer in the administration and supervision of the Contract arising from the granting of this permission.”

#### **SUB-CLAUSE 47.2: REDUCTION OF LIQUIDATED DAMAGES**

Add the following paragraphs at the end of this Sub-Clause:

“There shall be no reduction in the amount of liquidated damages in the event that a part or a section of the Works within the Contract is certified as completed before the whole of the Works comprising that Contract.

The Employer shall pay no bonus for early completion of the Works to the Contractor.

The sum stated in the Appendix to Bid as liquidated damages shall be increased by a sum equivalent to any additional amount payable by the Employer to the Contractor under clause 70.1 in respect of an increase in costs in such a period that would not have been incurred by the Contractor if the works had been completed by the due date for completion prescribed by Clause 43.”

#### **SUB-CLAUSE 52.1: VALUATION AND VARIATIONS**

Add new Clause 52.2(c)

No change in the unit rates or prices quoted shall be considered for items included in the schedule of day work rates, or Provisional Sums and items, or for any item in the BOQ.

**SUB-CLAUSE 52.4: DAYWORKS**

Add the following at the end of Sub-Clause 52.4:

The work so ordered shall immediately become part of the works under the contract. The Contractor shall, as soon as practicable after receiving the Day work order from the Engineer undertake the necessary steps for due execution such work. Prior to commencement of any work to be done on a Day work basis, the Contractor shall give an advance notice to the Engineer stating the exact time of such commencement.

**SUB-CLAUSE 54.1: CONTRACTORS EQUIPMENT, TEMPORARY WORKS AND MATERIALS: EXCLUSIVE USE FOR THE WORKS**

Amend Sub-Clause 54.1 as follows:

Line 5: add "written" between "the" and "consent".

Delete Sub-Clauses 54.2 and 54.5.

**SUB-CLAUSE 55.2: OMISSIONS OF QUANTITIES**

Items of Works described in the Bills of Quantities for which no rate or price has been entered in the Contract shall be considered as included in other rates and prices in the Contract and will not be paid for separately by the Employer.

Add the following Sub-Clause 58.4:

**SUB-CLAUSE 58.4: PROVISIONAL ITEMS**

Provisional items shall be read as Provisional Sums and shall be operated as such in accordance with Sub-Clauses 58.1 to 58.3.

**Clause 60: Certificates and Payment**

Clause 60 of the General Conditions is amended as follows:-

**SUB-CLAUSE 60.1: MONTHLY STATEMENT**

The Contractor shall submit a statement to the Engineer at the end of each month, in a tabulated form or in a manner approved by the Engineer, showing the amounts to which the Contractor considers himself to be entitled. The statement shall include the following items, as applicable;

- i. The value of the Permanent Work executed up to the end of that month
- ii. Such an amount (not exceeding 75 percent of the value) as the Engineer may consider proper on account of materials for permanent work delivered by the Contractor in the site
- iii. Such amount as the Engineer may consider fair and reasonable for any Temporary Works for which separate amounts are provided in the Bill of Quantities
- iv. Adjustments under Clause 70
- v. Any amount to be withheld under retention provisions of Sub-Clause 60.3
- vi. Any other sum to which the Contractor may be entitled under the Contract

If the Engineer disagrees with or cannot verify any part of the statement, the Contractor shall submit such further information as the Engineer may reasonably require and shall make such changes and corrections in the statement as may be directed by the Engineer. In cases where there is difference in opinion as to the value of any item, the Engineer's view shall prevail.

## **SUB-CLAUSE 60.2: INTERIM PAYMENT CERTIFICATE**

Within 30 days after receipt of the Contractor's statement and subject to the Contractor having made such further amendments and corrections as the Engineer may require, the Engineer will forward to the Employer an Interim Payment Certificate stating the amount of payment to the contractor which the Engineer considers due and payable in respect of the statement.

Provided that the Engineer shall not be bound to certify any payment under this Clause if the net amount thereof, after all retentions and deductions, would be less than the minimum amount of Interim Payment Certificate's stated in the Appendix to Form of Bid. However, in such a case, the uncertified amount will be added to the next interim payment, and the cumulative unpaid certified amount will be compared to the minimum amount of interim payment.

## **SUB-CLAUSE 60.3: RETENTION MONEY**

A retention amounting to the percentage stipulated in the Appendix to Form of Bid shall be made by the Engineer in the first and following Interim Payment Certificates until the amount retained shall reach the "Limit of Retention Money" named in the Appendix to Form of Tender.

Upon the issue of the Taking-Over Certificate, with respect to the whole of the works one half of the retention money shall become due and shall be paid to the Contractor when the Engineer shall certify in writing that the last section of the whole works has been substantially completed.

Upon expiration of the Defects Liability Period for the works, the other half of the Retention Money shall be certified by the Engineer for payment to the Contractor.

Provided that in the event of different Defects Liability Periods being applicable to different Sections of the Permanent Works pursuant to Clause 48, the expression "expiration of the Defects Liability Period" shall, for the purpose of this sub clause, be deemed to mean the expiration of the latest of such periods.

Provided also that if at such time, there remain to be executed by the Contractor any work instructed, pursuant to Clause 49 and 50, in respect of the works, the Engineer shall be entitled to withhold certification until completion of any such work or so much of the balance of the Retention money as shall in the opinion of the Engineer, represents the cost of the remaining work to be executed.

## **SUB-CLAUSE 60.4: CORRECTION OF CERTIFICATES**

The Engineer may in any Interim Payment Certificate make any correction or modification to any previous Interim Payment Certificate signed by him and shall have authority, if any work is not being carried out to his satisfaction to omit or reduce the value of such work in any Interim Payment Certificate.

## **SUB-CLAUSE 60.5: STATEMENT AT COMPLETION**

Not later than 28 days after the issue of the Taking-Over Certificate in respect of the whole of the works, the Contractor shall submit to the Engineer a statement at completion showing in detail, in a form approved by the Engineer;

The final value of all work done in accordance with the Contract up to the date stated in such Taking-Over Certificate.

- (a) Any further sums which the Contractor considers to be due; and
- (b) An estimate of amounts that the Contractor considers will become due to him under the Contract.

Estimate amounts shall be shown separately in the Statement at Completion. The Contractor shall amend and correct the Statement as directed by the Engineer and submit a Certificate at Completion to be processed as in Sub Clause 60.2.

#### **SUB-CLAUSE 60.6: FINAL STATEMENT**

Not later than 56 days after the issue of the Defects Liability Certificate pursuant to Sub-Clause 62.1, the Contractor shall submit to the Engineer for consideration a draft final statement with supporting documents showing in detail, in the form approved by the Engineer;

- a) The final value of all work done in accordance with the Contract;
- b) Any further sums which the Contractor considers to be due to him.

If the Engineer disagrees with or cannot verify any part of the draft final statement, the Contractor shall submit such further information as the Engineer may reasonably require and shall make such changes in the draft as may be required.

#### **SUB-CLAUSE 60.7: DISCHARGE**

Upon submission of the Final Statement, the Contractor shall give to the Employer, with a copy to the Engineer, a written discharge confirming that the total of the Final statement represents full and final settlement of all monies due to the Contractor arising out of or in respect of the Contract. Provided that such discharge shall become effective only after payment under the Final Payment Certificate issued pursuant to Sub-Clause 60.8 has been made and the Performance Security referred to in Sub-Clause 10.1 has been returned to the Contractor.

#### **SUB-CLAUSE 60.8: FINAL PAYMENT CERTIFICATE**

Upon acceptance of the Final Statement as given in Sub-Clause 60.6, the Engineer shall prepare a Final Payment Certificate which shall be delivered to the Contractor's authorized agent or representative for his signature. The Final Payment Certificate shall state:

- (a) The final value of all work done in accordance with the Contract;
- (b) After giving credit to the Employer for all amounts previously paid by the Employer, the balance, if any, due from the Employer to the Contractor or the Contractor to the Employer.

Final Certificate shall be issued for any sum due to the Contractor even if such is less than the sum named in the Appendix to the Form of Bid.

#### **SUB-CLAUSE 60.9: CESSATION OF EMPLOYERS LIABILITY**

Unless the Contractor notifies the Engineer of his objection to the Final Certificate within fourteen days of delivery thereof he shall be deemed to have agreed that he accepts the total Contract Price as set out in the Final Certificate as full settlement for all work done under the Contract including any variations and omissions thereof but excluding any variations and claims previously made in writing.

#### **SUB-CLAUSE 60.10: TIME FOR PAYMENT**

The amount due to the Contractor under any Interim Payment Certificate or Final Payment Certificate issued pursuant to this Clause or to any other term of the Contract, shall, subject to Clause 47, be paid by the Employer to the Contractor as follows:

- In the case of Interim Payment Certificate, within the time stated in the Appendix to Form of Bid, after the Engineer has signed the Interim Payment Certificate.
- In the case of the Final Payment Certificate pursuant to Clause 60.8, within the time stated in the Appendix to Form of Bid, after the Engineer has signed the Final Payment Certificate.
- In the event of the failure of the Employer to make payment within the times stated, the Employer shall make payment to the Contractor of simple interest at a rate equal to two percentage points (2%) above the Commercial average Base Lending Rate obtained from the Central Bank of Kenya. The provisions of this sub-clause are without prejudice to the Contractor's entitlements under Clause 69 or otherwise.

#### **SUB-CLAUSE 60.11: CURRENCY OF PAYMENT**

The Contract Price shall be designated in Kenyan Currency. All work performed by the Contractor under the Contract shall be valued in Kenya Shillings using the rates and prices entered in the Bills of Quantities

together with such other increases to the Contract Price, except for variation of price payments in accordance with Clause 70.1.

#### **SUB-CLAUSE 60.12: ADVANCE PAYMENT**

No advance payment shall be payable for provision of plant on site, erection of camp facilities, sureties, insurances, etc under this contract.

#### **SUB-CLAUSE 60.13: MATERIALS FOR PERMANENT WORKS**

With respect to materials brought by the Contractor to the site for incorporation into the permanent works, the Contractor shall,

- Receive a credit in the month in which these materials are brought to site,
- Be charged a debit in the month in which these materials are incorporated in the permanent works.

Both such credit and debit to be determined by the Engineer in accordance with the following provisions.

- (a) No credit shall be given unless the following conditions shall have been met to the Engineers satisfaction:-
- (i) The materials are in accordance with the specifications for the works;
  - (ii) The materials have been delivered to site and are properly stored and protected against loss, damage or deterioration;
  - (iii) The Contractors record of the requirements, orders receipts and use of materials are kept in a form approved by the Engineer, and such records are available for inspection by the Engineer;
  - (iv) The Contractor has submitted a statement of his cost of acquiring and delivering the materials and plant to the Site, together with such documents as may be required for the purpose of evidencing such cost;
  - (v) The materials are to be used within a reasonable time.
- (b) The amount to be credited to the Contractor shall not be more than 75% of the Contractor's reasonable cost of the materials delivered to site, as determined by the Engineer after review of the documents listed in subparagraphs (a) (iv) above;
- (c) The amount to be debited to the Contractor for any materials incorporated into the works shall be equivalent to the credit previously granted to the Contractor for such materials pursuant to Clause (b) above as determined by the Engineer.

#### **Sub-Clause 67.3: Arbitration**

Delete all the words from line 6 onwards beginning with the words "unless otherwise" up to line 8 ending with the words "... under such rules", and substitute with the following:

"by an arbitrator to be agreed upon between the parties or failing agreement to be nominated on the application of either party by the appointee designated in the form of Tender for the purpose and any such referee shall be deemed to be a submission to arbitration within the meaning of the Arbitration Laws of the Republic of Kenya.

#### **SUB-CLAUSE 68.2: NOTICES TO EMPLOYER AND ENGINEER**

Delete in Sub-Clause 68.2 the words "nominated for that purpose in part II of these conditions".

- a) The Employer's Address is:

**The Regional Manager  
Kenya Rural Roads Authority  
P.O Box 2718  
EMBU.**

b) The Engineer's Address is:

**The General Manager - Maintenance  
Kenya Rural Roads Authority  
P.O Box 48151 - 00100  
NAIROBI.**

#### **Sub-Clause 68.4 - Correspondences**

All letters and notices from the Contractor to the Employer and/or Engineer must be signed by the Managing Director or the person given written power of Attorney.

#### **CLAUSE 69: DEFAULT OF EMPLOYER**

Delete in Sub-Clause 69.1 (a) the words ("28 days") and insert the words "ninety (90) days".

Delete Sub-Clause 69.1 (c).

Delete in Sub-Clause 69.4 line 4 the words ("28 days") and insert the words "sixty (60) days".

In sub-clause 69.4 at the end of 1<sup>st</sup> paragraph add the following: "the period of such suspension shall be as agreed upon by both parties and in any case not more than six (6) months.

In Clause 69.4(b) of General Conditions of Contract Part I, insert at the end ----"The amount of such costs which shall be added to Contract Price shall exclude any cost due to idle time for equipment, plant and labour".

#### **CLAUSE 70: CHANGES IN COST AND LEGISLATION**

##### **Sub-Clause 70.1 - Increase or Decrease of Cost**

Delete Sub-Clause 70.1 of part 1 in its entirety and substitute the following:

"The Contract Price shall be deemed to have been calculated in the manner set below and shall be subject to the adjustment in the event specified hereunder:

The rates contained in the priced Bills of Quantities are based upon the rates of wages and other emoluments and expenses applicable at the site at the date of Bid pricing (as defined in Sub-Clause 70.4 hereinafter);

- (a) If the said rates of wages and other emoluments and expenses shall be increased or decreased by Act, Statute, Decree, Regulation and the like after the said Date of Bid Pricing then the net amount of increase or decrease the emoluments and expenses shall, as the case may be paid to or allowed by the Contractor;
- (b) The rates contained in the priced Bills of Quantities are based upon the rates of the Contractor's compulsory contributions payable at the date of Bid under or by virtue of any Act, Statute, Regulations and the like applicable at the site;
- (c) If any of the said rates of contribution shall be increased or decreased by any Act, Statute, Decree, Regulation and the like after the said Date of Bid Pricing, or if any new statutory contribution becomes payable after that date then the net amount of increase or decrease of the emoluments and expenses shall, as the case may be, be paid to or allowed by the Contractor. The difference between what the Contractor actually pays in respect of work people engaged upon or in connection with the works and what he would have paid in respect of such person had any of the said rates not been increased or decreased or had a new contribution not become payable as aforesaid, shall as the case may be, be paid to or allowed by the Contractor. Provided always that the Engineer and the Contractor may agree a sum which shall be deemed to be the net amount of the aforesaid difference, and such sum shall be deemed for the purpose of this contract to be that which is to be paid to or allowed by the Contractor by virtue of this sub-paragraph;

- (d) The rates contained in the priced Bills of Quantities are based upon the market prices of the materials and goods specified in the Schedule of Basic Materials attached hereto and current at the Date of Bid Pricing (hereinafter referred to as “the basic prices” and the Contractor shall state in the said schedule the basic prices of such materials and goods. Such prices shall be supported by bona fide quotations from suppliers;
- (e) If the market price of any materials or goods specified as aforesaid shall be increased or decreased after the said Date of Bid Pricing, then the net amount of difference between the basic price and the market price payable by the Contractor and current when any such goods and materials are bought shall, as the case may be, be paid to or allowed by the Contractor. Orders for materials and goods listed as aforesaid shall have been placed within a reasonable time after the date at which sufficient information is available for the placing of such orders, and the placing of orders at that time shall be a condition precedent to any payments being made to the Contractor in respect of increased market prices.”

**SUB-CLAUSE 70.2: SUBSEQUENT LEGISLATION**

Add the following to sub clause 70.2:

“Notwithstanding the foregoing, such additional or reduced cost shall not be separately paid for or credited as aforesaid if the same shall already have been taken into account in accordance with the other provisions of Clause 70.

Add the following sub clause:-

**SUB-CLAUSE 70.3: SUB-CONTRACT**

- (a) If the Contractor shall decide subject to Clause 4 thereof to sub-let any portion of the work he shall incorporate in the sub-contract provisions to the like effect as those contained in sub-clause (1) of this Clause;
- (c) If the price payable under a sub-contract as aforesaid is increased above or decreased below the price in such sub-contract by reason of the operation of the incorporated provisions of sub- clause (1) of this clause then the net amount of such increase or decrease shall as the case may be, be paid to or allowed by the Contractor under this contract.

**SUB-CLAUSE 70.4: NOMINATED SUB-CONTRACTORS**

This clause shall not apply in respect of work executed by any nominated sub-Contractor (fluctuation in relation to nominated sub-Contractors shall be dealt with under provisions in relation thereto which may be included in the appropriate sub-contract or contract of sale).

**SUB-CLAUSE 70.5: DATE OF BID PRICING**

The expression “the date of Bid pricing” as used in this Clause means the date 30 days prior to the final date for submission of Bids as determined by the Employer in the Bid documents.

**SUB-CLAUSE 70.6: PRIME COST**

For imported materials, the supplier’s/ manufacturer’s Prime costs shall be C.I.F. cost at point of entry by the same means of transport as determined by the Contractor’s Basic Rate.

For locally produced materials, the supplier’s or manufacturer’s prime costs shall be at their nearest depot relevant to the works.

For materials which are subject to Government Price Control, payments for price variations will be determined from the difference between the control price in force at a date 30 days prior to the final date for submission of Bids and the price in force on the date of purchase.



#### **SUB-CLAUSE 70.9: CONTRACTORS HEAD OFFICE EXPENSES**

No payments will be made for price variation related to expenses incurred by the Contractor in his Head Office in Kenya, or overseas.

#### **SUB-CLAUSE 70.10: CURRENCY OF PAYMENTS UNDER CLAUSE 70**

All payments made pursuant to Clause 70 shall be in Kenya Shillings.

#### **SUB-CLAUSE 70.11 - COST OF PREPARING VARIATION OF PRICE CLAIMS**

No payments will be made for the cost of preparing V.O.P. claims.

#### **CLAUSE 72 - RATES OF EXCHANGE COST**

Delete clause 72 in its entirety and substitute the following:

The currency of Bid and payment is Kenya Shillings and rates of exchange requirements are not applicable.

#### **CLAUSE 73: BRIBERY AND COLLUSION**

Add new clause 73.1:

“The Contractor shall not:

- (a) Offer or give or agree to give to any person in the service of the Government of Kenya any gift or consideration or any kind as an inducement or reward for doing or forbearing to do or for having done or forborne to do any act in relation to the obtaining or execution of this or any other contract to which the Government of Kenya is a party or for showing or forbearing to show favour or disfavour to any person in relation to this or any other contract for the Government of Kenya.
- (b) Enter into this or any other contract with the Government of Kenya in connection with which commission has been paid or agreed to be paid by or on his behalf or to his knowledge, unless before the contract is made particulars of any such commission and of the terms and conditions of any agreement for the payment thereof have been disclosed in writing to the Employer.  
Any breach of this condition by the Contractor or by anyone employed by him or acting on his behalf (whether with or without the knowledge of the Contractor) or the commission of any offence by the Contractor or by anyone employed by him or acting on his behalf in relation to this or any other contract to which the Government of Kenya is a party shall entitle the Employer to determine the Contract (See Condition 63 hereof) and/ or to recover from the Contractor the amount or value of any such gift, consideration or commission.

Any dispute or difference of opinion arising in respect of either the interpretation, effect or application of this condition or of the amount recoverable hereunder by the Employer from the Contractor shall be decided by the Employer, whose decision shall be final and conclusive.

#### **ADDITIONAL CLAUSES**

#### **CLAUSE 73 DECLARATION AGAINST WAIVER**

The condoning by the Employer of any breach or breaches by the Contractor or any authorized sub-contractor of any of the stipulations and Conditions contained in the Contract shall in no way prejudice or affect or be construed as a waiver of the Employer's rights, powers and remedies under the Contract in respect of any breach or breaches as aforesaid.

#### **CLAUSE 74 BRIBERY AND COLLUSION**

The Employer shall be entitled to determine the Contract and recover from the Contractor the amount of any loss resulting from such determination if the Contractor shall have offered or given or agreed to give any person any gift or consideration of any kind as an inducement of regard for doing or fore

bearing to do or for having done or fore borne to do any action in relation to obtaining or the execution of the Contract or any other contract with the Employer or if any of the like acts shall have been done by any person employed by the Contractor or acting on his behalf (whether with or without the knowledge of the Contractor) or if the Contractor shall have come to any agreement with another contractor or number of contractors whereby an agreed quotation or estimate shall be tendered to the Employer by one or more contractors.

#### **CLAUSE 75 CONTRACT CONFIDENTIAL**

The Contractor shall treat the Contract and everything in connection therewith as private and confidential. In particular, the Contractor shall not publish any information, drawings or photographs concerning the Works in any trade or technical paper etc, and shall not use the Site for the purpose of advertising except with the written consent of the Engineer and subject to such conditions as the Engineer may prescribe.

#### **CLAUSE 76 EMPLOYER'S OFFICIALS ETC., NOT PERSONALLY LIABLE**

No official of the Employer or the Engineer or the Engineer's Representative or anyone of their respective staffs or their employees shall be in any way personally bound or liable for the acts or obligations of the Employer under the Contract or answerable for default or omission in the observance or performance of any of the acts, matters or things which are herein contained.

#### **CLAUSE 77 TAXES AND DUTIES**

- (1) The Contractor shall list in his tender the plant and vehicles which he intends to import for the execution of the Works. The Engineer will consider the list in the context of the program of the Works and will give his approval subject to any modifications that he may see fit to make. No appeal against the Engineer's decision shall be permitted.

The Contractor will be permitted to import approved plant and vehicles required for the execution of the Works on the basis of temporary admission into Kenya and re-export thereafter upon completion of the Contract without payment of customs duties and Value Added Tax for them. If the plant and equipment shall not be re-exported, duties and taxes shall then be paid based upon their residual value at the date of completion of the Contract, or the date of withdrawal from the Works, if earlier. Plant and vehicles so imported shall not be utilized on other works not associated with the Contract unless specifically authorized by the Engineer.

- (2) The Contractor will be permitted to import approved spare parts, tires and tubes without payment of customs duty and Value Added Tax for maintenance of any imported vehicles and plant as provided in sub-clause 77.1 above, within a financial limit indicated by himself. However, this limit will not exceed 15% of the Contract Price excluding Contingencies.
- (3) All materials approved by the Engineer to be incorporated into the Works or temporary works, and whose importation into Kenya is agreed to be essential shall be free of customs duties and Value Added Tax. The Contractor shall submit a list of such materials required with the tender. The Contractor shall be required to satisfy the Engineer that such materials have actually been incorporated into the Works.

Items produced in Kenya will not be permitted to be imported without payment of customs duty and Value Added Tax.

Items produced in Kenya shall mean commercially recognized goods or products that are either mined, grown, manufactured, processed or assembled (whether the components are imported or not) in Kenya.

#### **CLAUSE 79 JOINT VENTURES**

79.1 If the Contractor is a joint venture, all partners of the joint venture shall be jointly and severally liable to the Employer for the execution of the entire Contract in accordance with its terms and Conditions.

## V) SPECIAL SPECIFICATIONS

### SECTION 1: GENERAL

#### 101 LOCATION AND EXTENT OF SITE

The Project is located in Runyenjes Constituency within Embu County. The road section starts from Mufu-Karungu (C406). The site of the works shall be the area within the road reserve and any other places as may be designated in the contract and directed by the engineer's representative.

#### 102 EXTENT OF CONTRACT.

The works to be executed under this contract consist of, but are not limited to, the following:

- Site Clearance
- Culvert And Drainage Works
- Grading and gravelling works

The Works detailed above are only indicative of the Scope of Works associated with this contract and the Engineer may, where necessary, substitute some of the Works with others within the project area without substantially altering the overall Scope of the Works. Work shall be measured and paid using the relevant rates and prices in the Bill of Quantities.

The works will also include for any operations necessary for the safe and convenient passage of through and local traffic at all times.

#### 104 PROGRAMME OF EXECUTION OF THE WORKS

The contractor shall provide the works program, required under clause 14 of the Conditions of Contract, within 14 days of receipt of the Engineer's Order to commence work.

The program shall be coordinated with climatic and other conditions to provide for the completion of the works in the order and by the time specified.

The Contractor shall carry out the contract in accordance with the program agreed with the Engineer, but he shall in no manner be relieved by the Engineer's approval of the program, of his obligation to complete the works in the prescribed order and by the prescribed completion date and he shall from time to time review his progress and make such amendments to his rate of execution of the works as may be necessary to fulfill his obligations.

#### 105 ORDER OF EXECUTION OF WORKS

In addition to Clause 105 of the Standard Specification the Contractor shall carry out the Works such that a continuous and consecutive output of fully completed work is achieved. The Resident Engineer shall be required to check the contractor's work execution progress guided by the Supervision Checklist provided as **Appendix II** to these Special Specifications.

#### 107 TAKING OVER CERTIFICATE

The minimum length of road for which a taking over certificate will be issued shall be the whole road when completed.

#### 109 NOTICE OF OPERATIONS

It shall be the Contractor's responsibility to notify the Engineer when any item of works scheduled are completed and ready for approval, and the contractor shall give sufficient notice to allow control test to be performed.

## **117 HEALTH, SAFETY AND ACCIDENTS**

The Contractor shall ensure a safe and healthy implementation of the project by providing fully equipped First Aid kits throughout the contract period in accordance with the Laws of Kenya. There is no separate payment for these requirements and the costs should be included in the Contractor's rates and prices generally.

## **123 LIAISON WITH GOVERNMENT AND POLICE OFFICIALS**

The Contractor shall keep in close touch with the Police and the other Government officials of the area regarding their requirements in the control of traffic or other matters, and shall provide all assistance or facilities, which may be required by such officials in the execution of their duties.

## **124 LAND FOR ALL CAMPS SITES AND FOR THE CONTRACTOR'S OWN PURPOSES, INCLUDING TEMPORARY WORKS.**

Notwithstanding Clause 124 of the Standard Specification all requirements of land for temporary works and construction purposes shall be to the approval of the Engineer but the Contractor will make all necessary arrangements with the property owners concerned and pay all charges arising there from. On or before completion of the Contract, the Contractor shall remove all temporary works and shall restore all such land to the condition in which it was immediately prior to the occupation thereof as far as s reasonable and practicable. No separate payment will be made to the Contractor on account of these items and the Contractor must make due allowance for them in his rates.

Notwithstanding Clause 120 of the Standard Specifications, the Contractor shall be required to appoint a competent surveyor who will liaise with the Engineer on matters related to the demarcation of the existing road reserve, site measurements, removal and reinstatement of existing services.

## **128 STORAGE OF MATERIALS**

All materials shall be stored on Site in a manner approved by the Engineer and the Contractor shall carefully protect from the weather all work and materials which may be affected thereby.

## **129 TEST CERTIFICATES**

When instructed by the Engineer the Contractor shall submit certificates of test from the suppliers of materials and goods required in connection with the works as the Engineer may require.

Such certificates shall certify that the materials or goods concerned have been tested in accordance with the requirements of the specifications and shall give the results of all the tests carried out. The Contractor shall provide adequate means of identifying the materials and goods delivered to the site with the corresponding certificates.

## **137 ATTENDANCE UPON THE ENGINEER AND HIS STAFF**

The costs, for attendance required by this Clause 137, shall include attendance to staff, as required by the Engineer, shall be paid for under Item 01-80-030 of the Bill of Quantities.

## **142 ENVIRONMENTAL PROTECTION**

The Contractor shall comply with the Statutory Regulations in force in Kenya regarding environmental protection and waste disposal. In so doing, the Contractor shall liaise with the National Environmental Management Agency (NEMA).

## **SECTION 2: MATERIALS AND TESTING OF MATERIALS**

All materials testing shall be in accordance with section 2 of the Standard Specifications.

## **SECTION 3: SETTING OUT & TOLERANCES**

### **301 SETTING OUT**

All setting out shall be done in accordance with Section 3 of the Standard Specifications.

### **SECTION 4: SITE CLEARANCE AND TOP SOIL STRIPPING**

Site clearance is to be confined within the road reserve width area and shall be done to the satisfaction of the Engineer and in any case include but not limited to cutting of all bush to a maximum height of 50mm above the ground, removal of tree stumps, grubbing and disposal of the resultant debris in an environmental friendly manner to the approval of the Engineer,

### **SECTION 7 - EXCAVATION AND FILLING OF STRUCTURES**

#### **703 EXCAVATION OF FOUNDATIONS FOR STRUCTURES**

Unless otherwise instructed by the Engineer, all excavated surfaces in material other than hard material, shall be compacted to 100% MDD (AASHTO T.99) immediately before structures are constructed.

#### **707 BACKFILLING FOR STRUCTURES**

Unless otherwise instructed by the Engineer, all backfilling material shall be compacted to a minimum of 100% MDD (AASHTO T.99).

#### **711 GABIONS**

Where instructed by the Engineer the Contractor shall install gabions as protection works to unstable embankments, washout areas or bridge Piers, and or Abutments. Gabions shall be constructed in accordance with Clause 711 of the Standard Specification.

In cases where existing gabions have been damaged, the Contractor shall identify them and notify the Engineer for his agreement of the extent of the Work required and his approval and instructions to proceed with the Works.

The Works shall involve removal of the damaged gabions / rocks, excavation to the correct levels and grades as directed by the Engineer, and in accordance with Clause 711 of the Standard Specifications and reconstruction with new gabions and other necessary materials as necessary. The damaged gabions shall be recovered and transported to the KeRRA Regional office.

#### **714 BACKFILL BELOW STRUCTURES**

Where instructed this shall be carried out in compliance with the requirements of Clause 507 and 804 of the Standard Specification

### **SECTION 8 - CULVERTS AND DRAINAGE WORKS**

#### **801 SCOPE OF SECTION**

The operations specified in this section apply to reinstatement and improvement of drainage works.

This Section covers:-

- Desilting and cleaning of existing pipes and outfall drains to make them free flowing.

#### **817 REPAIRS TO DRAINS**

##### **817.1 Cleaning Existing Drains**

In areas of existing side drains, mitre or outfall drains where such are blocked, the Engineer shall instruct the Contractor to clean and clear the drains to free flowing condition.

The work shall consist of:

- (a) Stripping and removal of any extraneous material to spoil including vegetation and roots in the drains to the satisfaction of the engineer.
- (b) Spreading of any spoil to the satisfaction of the Engineer.
- (c) Shaping the drains to free flowing condition.

Cleaning any closed structures including cross culverts of any size to free flowing conditions.

Measurement and Payment for cleaning drains shall be by cubic metre of drain cleaned measured as the product of plan area and vertical depth of extraneous material instructed to be removed. No extra payment will be made for removal of vegetation and roots.

## **819 CLEANING AND MAINTENANCE**

### **819.1 De-silting of Pipe Culverts**

Where instructed, Contractor shall desilt the existing pipe culverts by removing all the material from the pipe to make them clean and free flowing.

Measurement and payment shall be by the linear metres of pipes de-silted, regardless of diameter size.

## **SECTION 10 - GRAVEL WEARING COURSE**

### **1001 GENERAL**

#### **(a) Definitions**

The term "gravel" used throughout this Section means any material used as a wearing course, and shall include lateritic gravel, quartz tic gravel, calcareous gravel, decomposed rock, soft stone, coral rag, clayey sands and crushed rock.

### **1003 MATERIAL REQUIREMENTS**

The material shall have a minimum CBR of 20 at 95% MDD (AASHTO T180) and 4 days soak.

The plasticity requirements and the class of material shall be as specified in the RDM manual for Class I gravel.

### **1007 LAYING AND COMPACTING GRAVEL WEARING COURSE**

The gravel wearing course material shall be deposited in such quantity and spread in a uniform layer across the full width required, so that the final compacted thickness is nowhere less than shown upon the Drawings or instructed by the Engineer. Every reasonable effort shall be made to prevent segregation during the loading, hauling, dumping, spreading, mixing, trimming and compacting operations.

The compacted thickness of any layer laid, processed and compacted at one time shall not exceed 225 mm and where a greater compacted thickness is required, the material shall be laid and processed in two or more layers. The minimum layer thickness shall be 100 mm.

### **1008 PROOFROLLING**

The Contractor shall proof roll the completed layers in accordance with Clause 1205 of this Specification.

## **1010 MAINTENANCE**

The wearing surface shall be maintained by the Contractor in its finished condition and shall be watered, graded, dragged, reshaped, or re-compacted as necessary, until the Certificate of Completion is issued, or until the Engineer instructs that the road shall be opened to public traffic, whichever is the sooner.

## **1011 MEASUREMENT AND PAYMENT**

(a) Item: Gravel wearing course

Unit: m<sup>3</sup> of each type in each method of measurement.

## **SECTION VI**

### **DRAWINGS**

Standard Drawings may be used where necessary.

### **DRAWINGS**



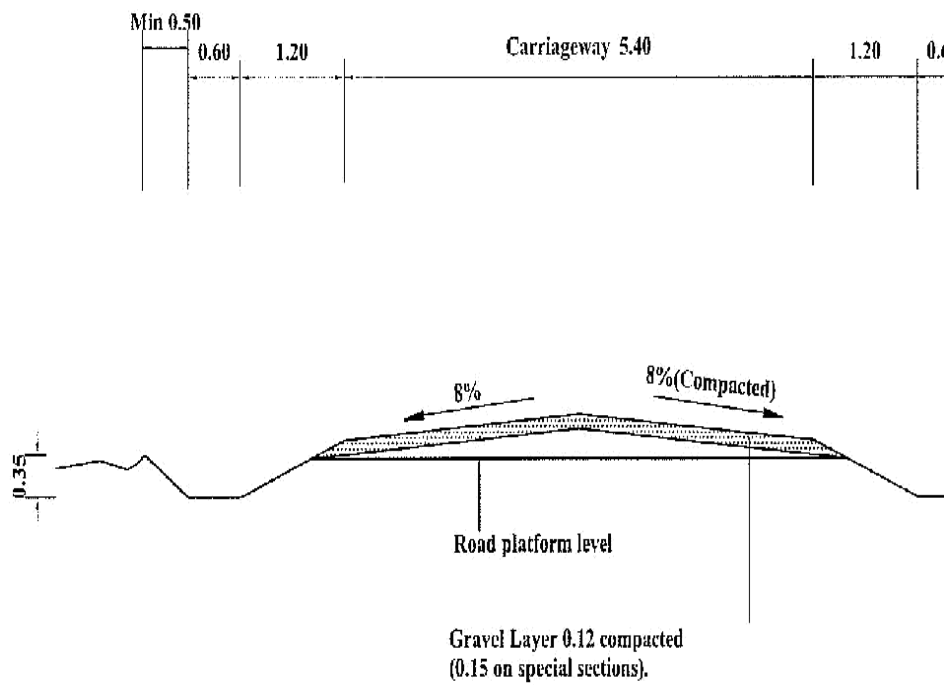

**Notes:**

1. All dimensions in metres
2. Traffic levels of > 200vpd may justify a carriageway width of 6.0m
3. Gravel thickness may be increased as directed by the Engineer

L-2

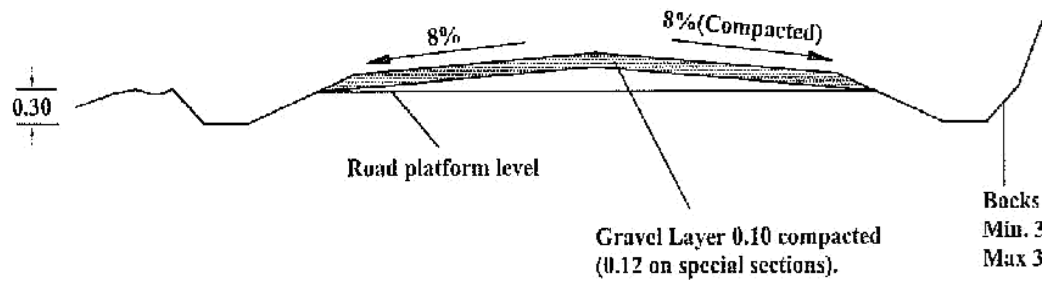
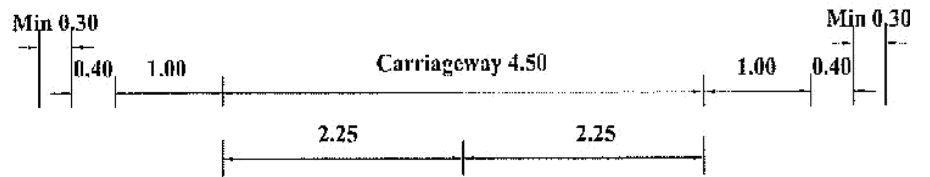

**Notes:**

1. All dimensions in metres
2. Gravel thickness may be increased as directed by the Engineer

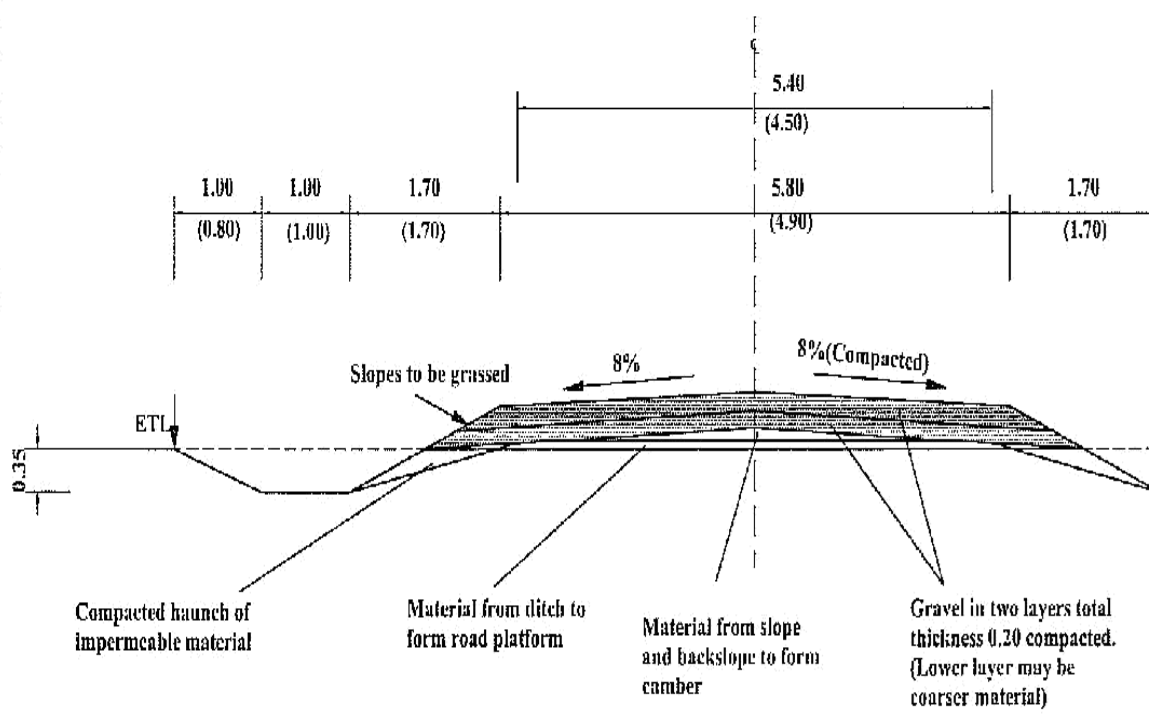

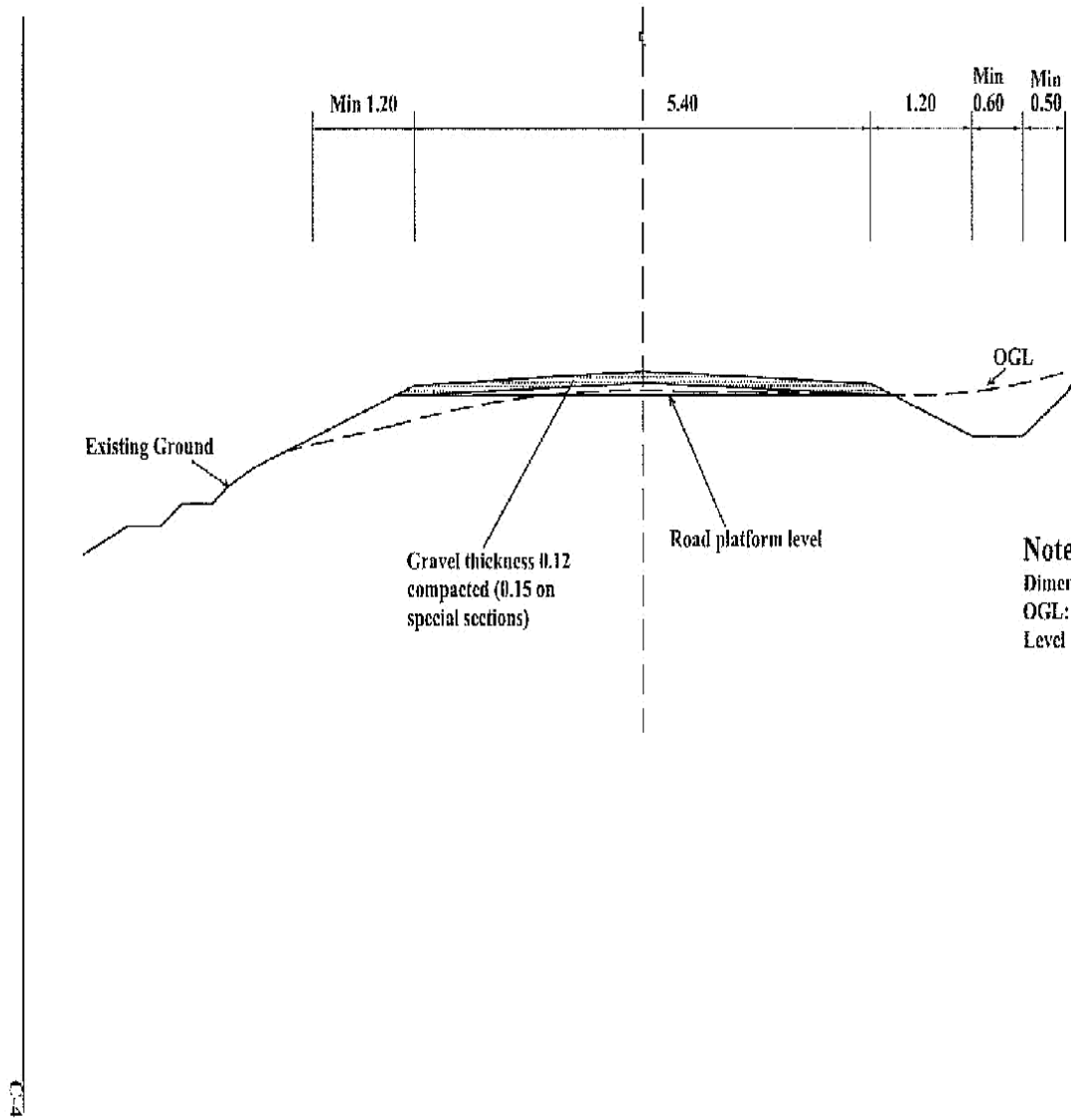

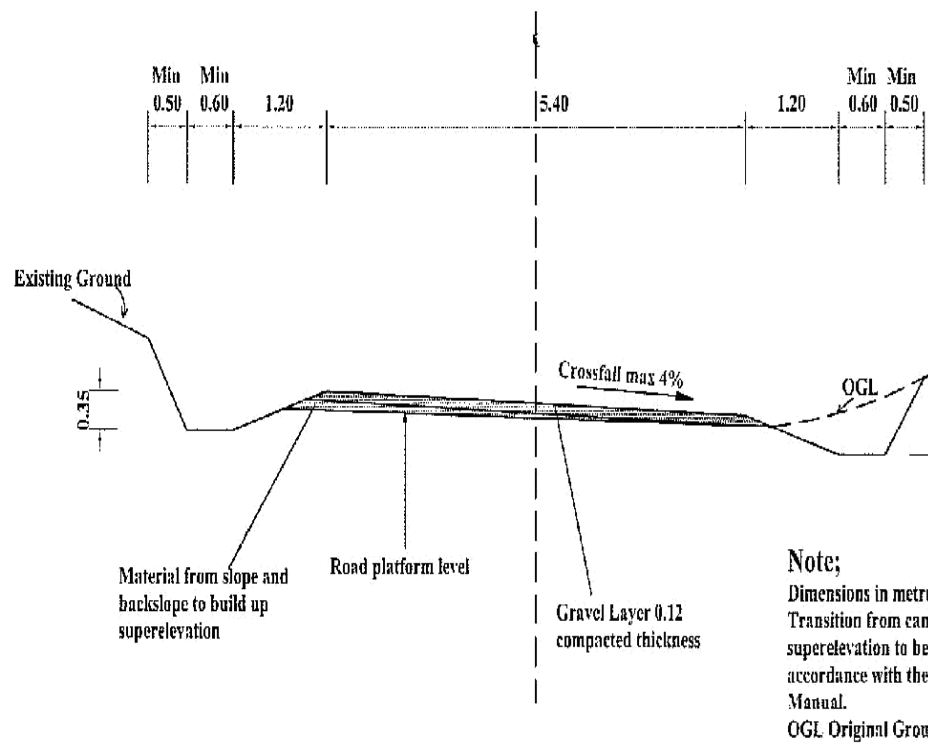

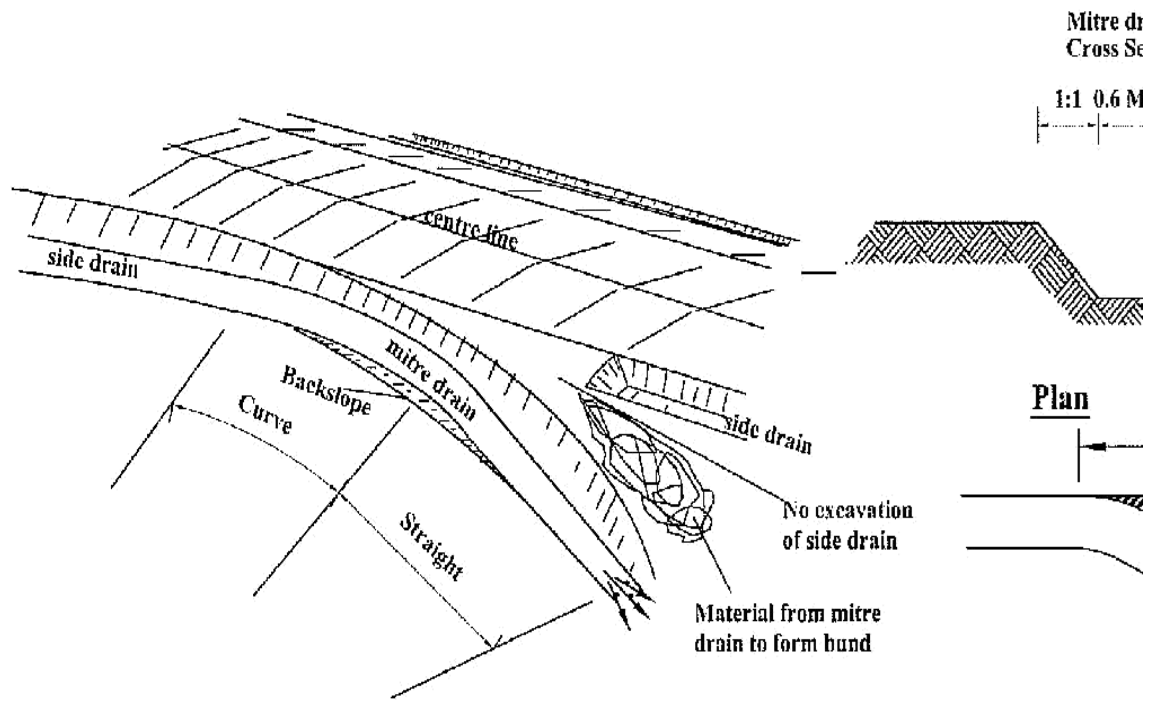

### Notes

Location, direction and length of the mitre drain to be determined by the Engineer

Scour checks made of wooden stakes

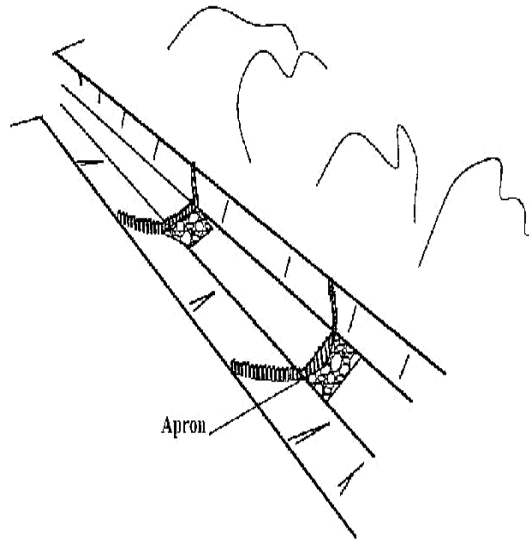

Scour checks made of stones

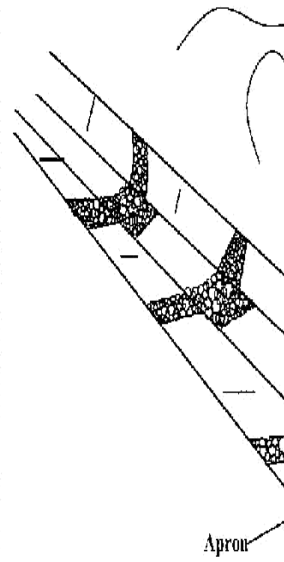

**Scour checks made of stones**

**Cross section**

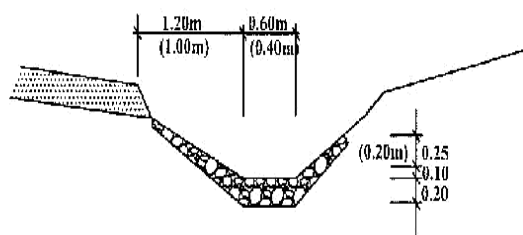

**Ground plan**

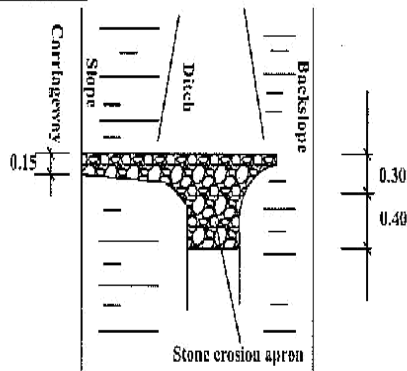

**NOTE**  
1. Dimensions in metres

**Scour checks made of stakes**

**Cross section**

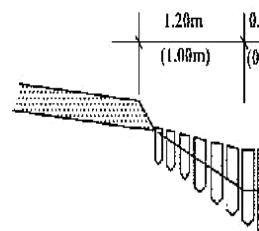

**Ground plan**

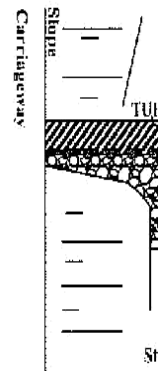

**STONE WEIGHT: MIN 10KG**  
**STAKE DIAMETER: MIN. 0.10**





**SECTION OF MASONRY SCOUR CHECK**

Note  
[Dimensions in mm

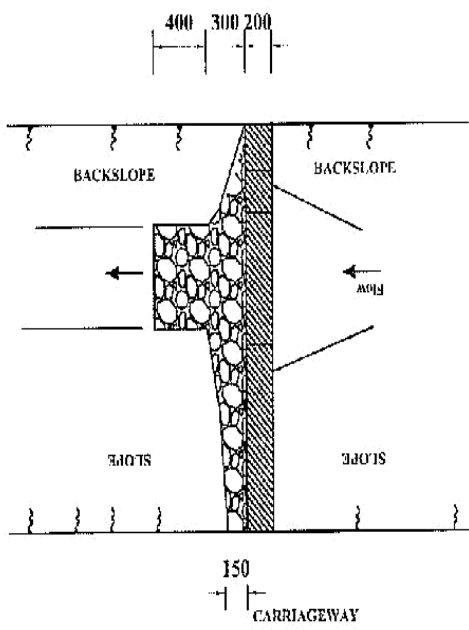

**PLAN OF BRAIN WITH SCOUR CHECK**

Cross-Section	Size (in mm)			Slope (m:1)	Length of (m:1)	Area (sqm)
	Length	Width	Depth			
A	2400	300	550	0.22	0.25	0.18
B	2000	200	500	0.18	0.2	0.14

7

**SECTION OF CONCRETE SCOUR CHECK**

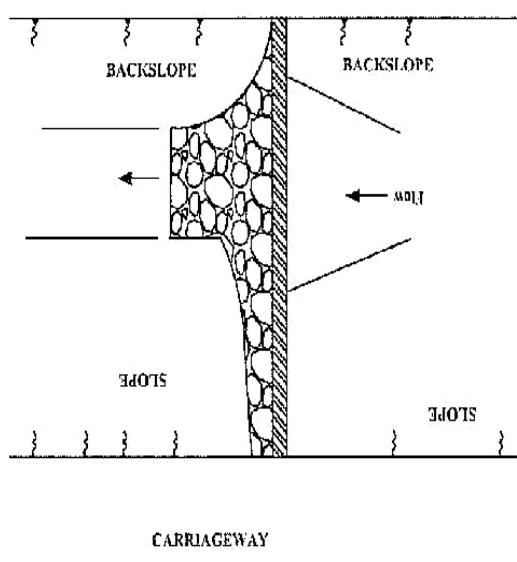

**NOTE**  
1. Dimensions in mm

**PLAN OF DRAIN WITH SCOUR CHECK**

Cross-Section	Sizes in mm		Excav (m <sup>3</sup> )	Concrete (m <sup>3</sup> )	Apron stone pitching (m <sup>3</sup> )	
	Length	Width				Depth
A	2400	100	550	0.13	0.15	0.18
B	2000	100	500	0.10	0.09	0.14

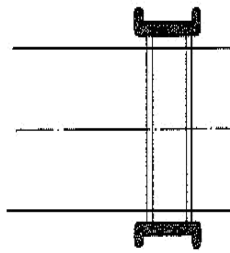
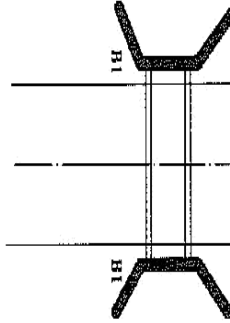

TYPE 2(ENTRY ONLY)

TYPE 4(ENTRY AND EXIT ON ACCESS)

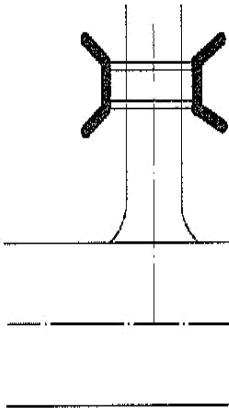
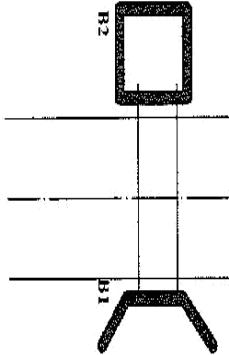

NOTE  
 1. The code numbers specify the shape and function and the code letter denotes the material:  
 A = Concrete block  
 B = Stone masonry  
 C = Concrete

**SECTION A-A**

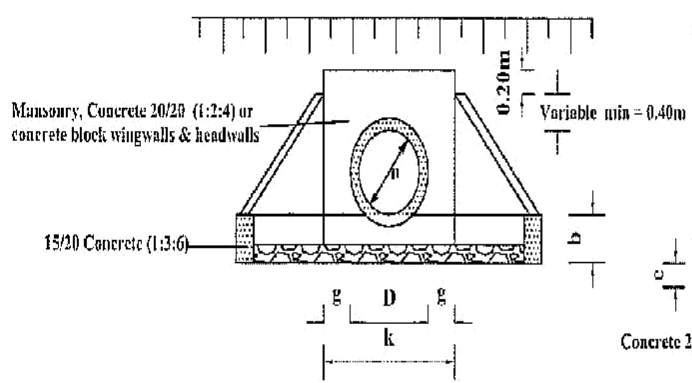

**SECTION B-B**

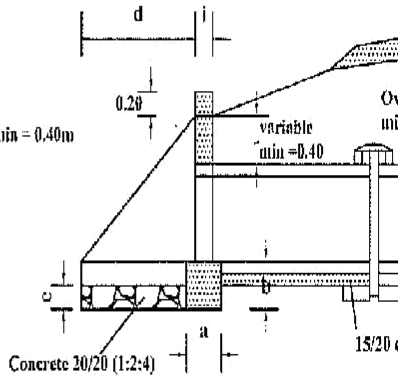

**PLAN**

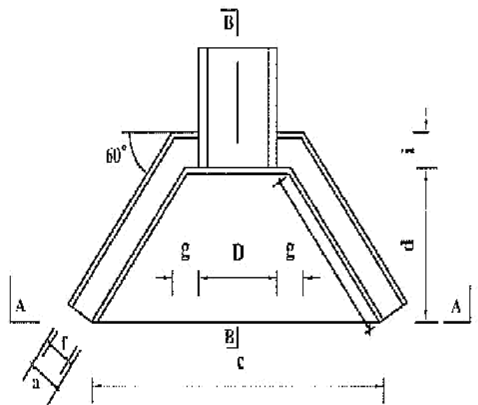

CULVERT TYPES	
X-SECTION WIDTH m	No. of pipes
4.50	6
5.50	7
6.50	8

PIPE DIAMETER IN M	UNIT	TYPE A and C CONCRETE BLA		
		450	600	
a	FOUNDATION	m	0.30	0.30
b	FOUNDATION	m	0.30	0.30
c	FOUNDATION	m	2.20	2.35
d	APRON	m	1.00	1.00
e	APRON	m	0.20	0.20
f	WALL	m	0.20	0.20
g	WALL	m	0.30	0.30
h	WALL	m	1.15	1.15
i	WALL	m	0.20	0.20
k	APRON	m	1.05	1.20
MATERIAL REQUIREMENT				
FOUNDATION (concrete)		m <sup>3</sup>	0.30	0.32
HEAD/WINGWALLS (Concrete/Masonry)		m <sup>3</sup>	0.42	0.49
APRON (concrete)		m <sup>3</sup>	0.33	0.36

**SECTION A-A**

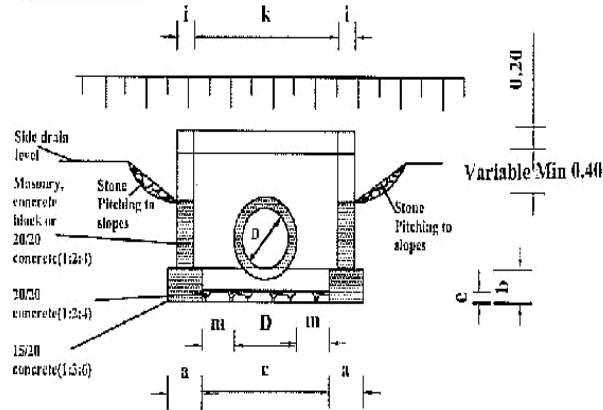

**SECTION B-B**

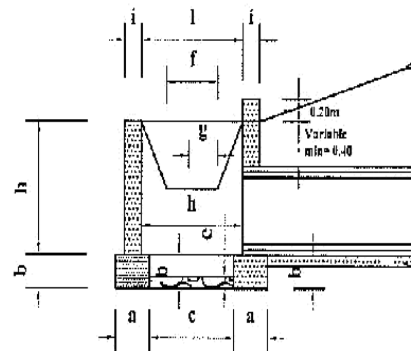

**PLAN**

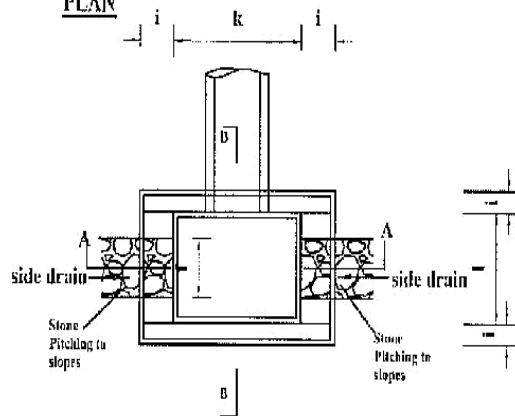

**DIMENSIONS AND MATERIAL REQUIREMENTS**

PIPE DIAMETER IN (M)	TYPE A CONCRETE BLOCKS			TY M <sup>3</sup>		
	450	600	900			
	UNIT			45		
a	FOUNDATION	m	0.30	0.30	0.30	0.4
b	FOUNDATION	m	0.30	0.30	0.30	0.3
c	FOUNDATION	m	1.10	1.10	1.40	1.2
d	APRON	m	0.90	0.90	0.90	1.0
e	APRON	m	0.20	0.20	0.20	0.2
f	DROP INLET	m	0.60	0.60	0.60	0.6
g	DROP INLET	m	0.30	0.40	0.60	0.3
h	DROP INLET	m	0.60	0.80	1.20	0.6
i	DROP INLET	m	0.20	0.20	0.20	0.4
k	DROP INLET	m	1.20	1.20	1.50	1.2
l	DROP INLET	m	1.00	1.00	1.00	1.0
m	DROP INLET	m	0.38	0.30	0.30	0.3
<b>MATERIAL REQUIREMENT</b>						
FOUNDATION (concrete)		m <sup>3</sup>	0.47	0.47	0.52	0.7
HEAD/WINGWALLS (Concrete/Masonry)		m <sup>3</sup>	0.56	0.72	1.15	1.2
APRON (concrete)		m <sup>3</sup>	0.24	0.24	0.30	0.2

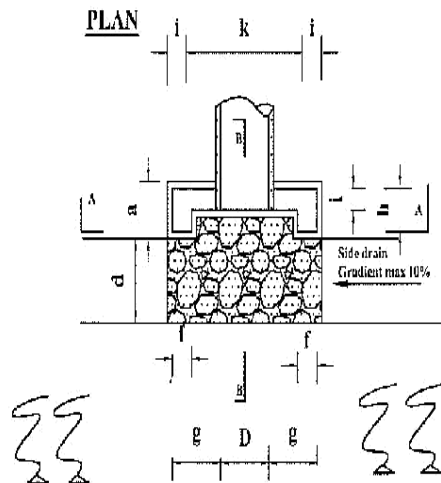
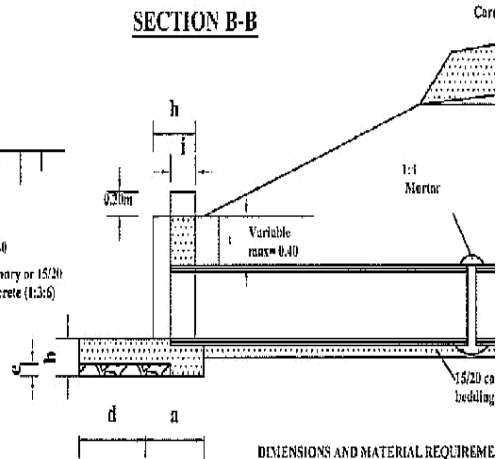
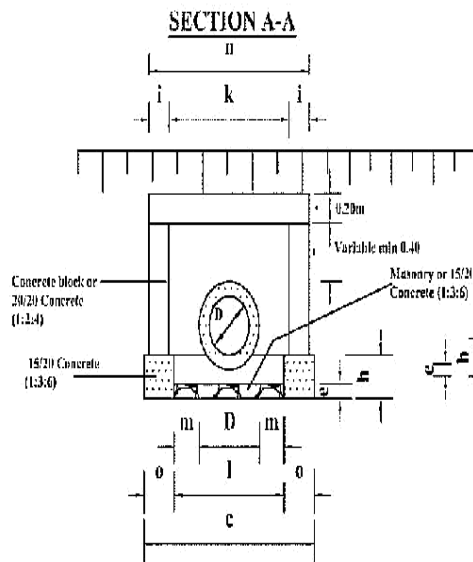

**DIMENSIONS AND MATERIAL REQUIREME**

PIPE DIAMETER IN (M)	DIMENSION	UNIT	TYPE A and C C BLOCKS		
			450	600	
	a	FOUNDATION	m	0.50	0.50
	b	FOUNDATION	m	0.30	0.30
	c	FOUNDATION	m	1.95	1.70
	d	APRON	m	0.60	0.60
	e	APRON	m	0.20	0.20
	f	HEADWALL	m	0.20	0.20
	g	HEADWALL	m	0.50	0.50
	h	HEADWALL	m	0.50	0.50
	i	HEADWALL	m	0.50	0.50
	k	HEADWALL	m	0.50	0.50
	l	FOUNDATION	m	0.50	0.50
m	FOUNDATION	m	0.50	0.50	
n	HEADWALL	m	0.50	0.50	
o	FOUNDATION	m	0.50	0.50	
<b>MATERIAL REQUIREMENT</b>					
FOUNDATION (concrete)			0.23	0.19	
HEADWING/WALLS (Concrete/Masonry)			0.34	0.37	
APRON (concrete)			0.08	0.09	

**SECTION A-A**

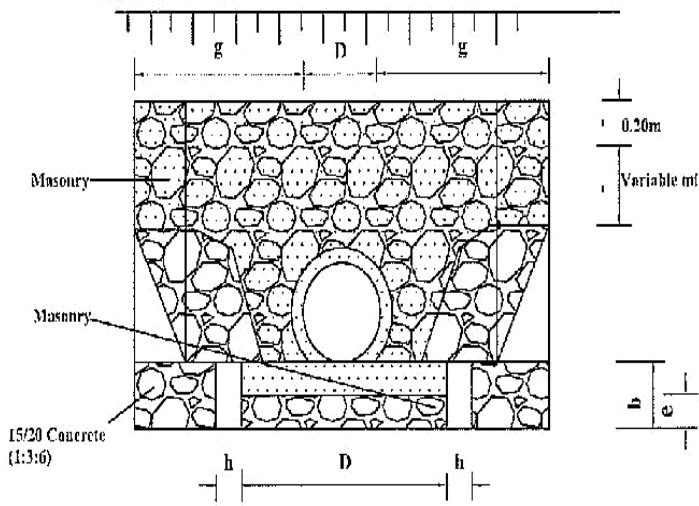

**SECTION B-B**

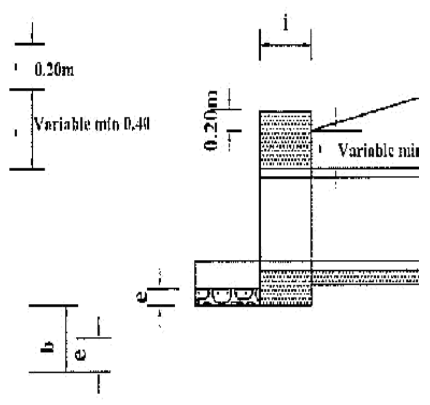

**PLAN**

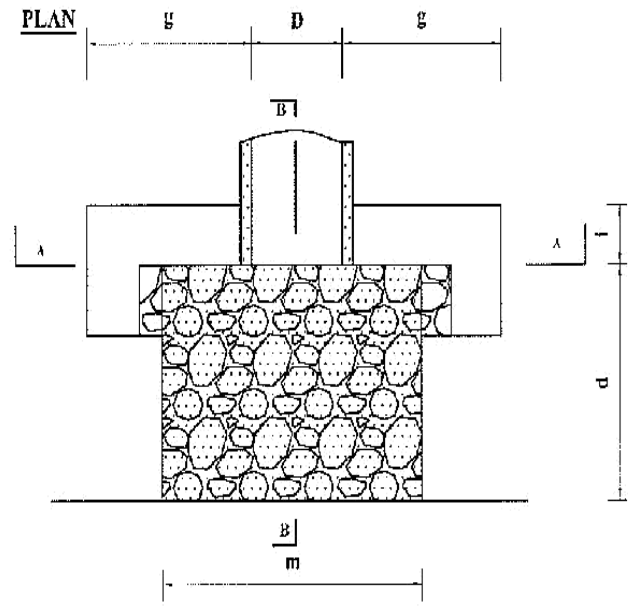

**DIMENSIONS AND**

PIPE DIAMETER (M)	
DIMENSION	
a	FOUNDATION
b	FOUNDATION
c	FOUNDATION
d	APRON
e	APRON
f	HEADWALL
g	HEADWALL
h	HEADWALL
i	HEADWALL
m	FOUNDATION
MATERIAL REQ	
FOUNDATION (concrete)	
HEAD/WING (Concrete/Maso)	
APRON (concrete)	

**SECTION A-A**

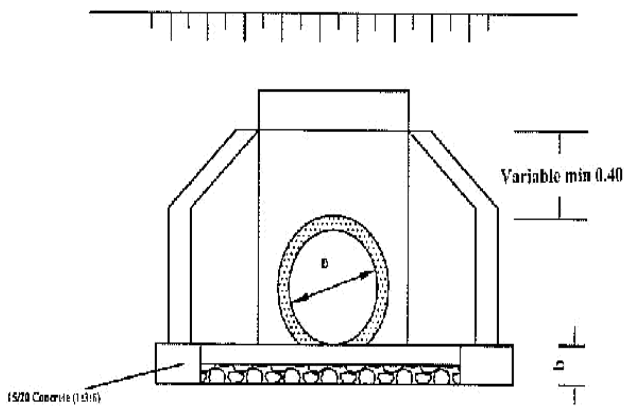

B D C

**PLAN**

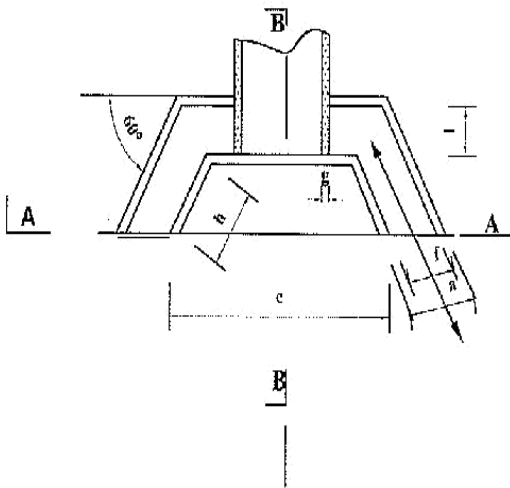

**SECTION B-B**

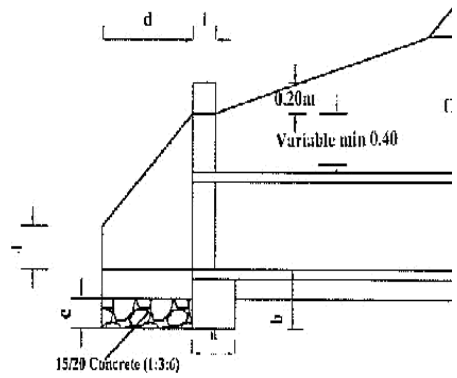

**DIMENSIONS AND MATERIAL REQUIREMENTS**

PIPE DIAMETER IN (M)	DIMENSION	UNIT	TYPE A (CONCRETE BLOCKS)		
			450	600	900
a	FOUNDATION	m	0.30	0.30	
b	FOUNDATION	m	0.30	0.30	
c	APRON	m	1.34	1.49	
d	APRON	m	0.90	0.60	
e	APRON	m	0.20	0.20	
f	WINGWALLS	m	0.20	0.20	
g	WINGWALLS	m	0.10	0.10	
h	HEADWALLS	m	0.69	0.69	
i	HEADWALLS	m	0.20	0.20	
k	HEADWALLS	m	0.65	0.80	
l	HEADWALLS	m	0.40	0.40	
<b>MATERIAL REQUIREMENT</b>					
FOUNDATION (concrete 1:3:6)			0.18	0.20	
HEAD/WINGWALLS (Concrete/Masonry)			0.28	0.32	
APRON (concrete)			0.12	0.14	





Diameter (D)	450 (mm)	600 (mm)	900 (mm)
	a	0.15	0.20
b	0.10	0.15	0.15
c	0.86	1.12	1.48
d	0.56	0.72	1.08
e	0.14	0.18	0.27
f (min)	0.34	0.45	0.68
g	-	-	-
h	0.24	0.33	0.42
i	-	-	-
Concrete	Volume in (m <sup>3</sup> /m)		
Class 15/20	0.24	0.24	0.24
Application	-Fair subgrade condition -Overfill > 75% of the pipe diameter -Seasonal water flow only		
Remarks	Material for back/overfill shall be approved by the Engineer		

Diameter (D)	450 (mm)	600 (mm)	900 (mm)
	a	0.15	0.20
b	0.10	0.15	0.15
c	0.86	1.12	1.48
d	0.56	0.72	1.08
e	0.28	0.36	0.54
f (min)	0.34	0.45	0.68
g	-	-	-
h	0.38	0.51	0.69
Concrete	Volume in (m <sup>3</sup> /m)		
Class 15/20	0.20	0.37	0.56
Application	-Fair to poor subgrade condition -Overfill > 75% of the pipe diameter -Seasonal water flow only		
Remarks	Material for back/overfill shall be approved by the Engineer		

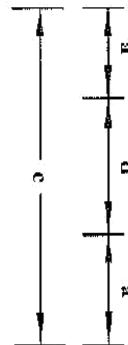
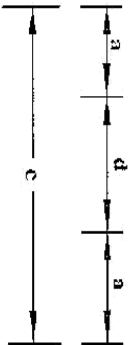
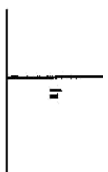
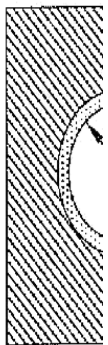
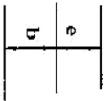

Diameter (D)	450 (mm)	600 (mm)	900 (mm)
a	0.15	0.20	0.20
b	0.10	0.15	0.15
c	0.86	1.12	1.48
d	0.56	0.72	1.08
e	0.42	0.54	0.81
f (min)	0.23	0.3	0.45
g	-	-	-
h	0.52	0.69	0.96
i	-	-	-

450 (mm)	600 (mm)	900 (mm)
0.15	0.20	0.20
0.10	0.15	0.15
0.86	1.12	1.48
0.56	0.72	1.08
0.46	0.52	0.78
0.15	0.15	0.15
0.15	0.15	0.15
0.81	1.02	1.38
0.28	0.35	0.45

Concrete Class	15/20
Volume In (m <sup>3</sup> /m)	0.26

Volume In (m <sup>3</sup> /m)	0.37	0.61	0.92
-Fair to poor subgrade condition			
-Overfill > 75% of the pipe diameter			
-Seasonal water flow only			

**Application**  
 -Fair subgrade condition  
 -Overfill > 75% of the pipe diameter  
 -Seasonal water flow only

**Remarks**  
 Material for back/overfill shall be approved by the Engineer

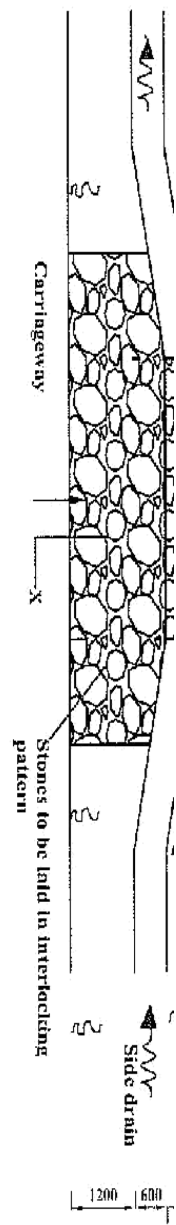

150mm Grouted Stone Pitching  
(Cement mortar 1:4)

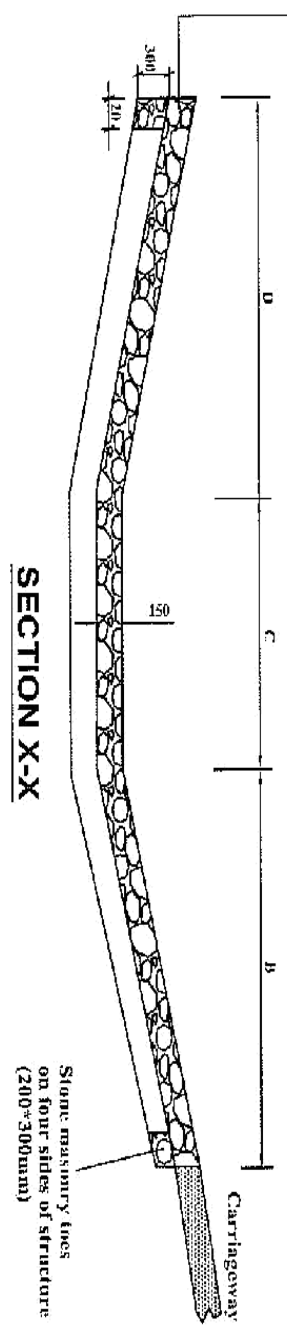

SECTION X-X

QUANTITIES TABLE

Cross section	DIMENSIONS					Excavation(m <sup>3</sup> )	Stone masonry (m <sup>3</sup> )	150mm Grouted stone pitching(m <sup>3</sup> )
	A	B	C	D	E			
A	4000	1800	600	1800	4200	7.5	1.30	21.75
	6000	1800	600	1800	4200	10.00	1.60	30.15
B	4000	1400	400	1800	3600	7.00	1.20	18.30
	6000	1400	400	1800	3600	9.00	1.50	25.50

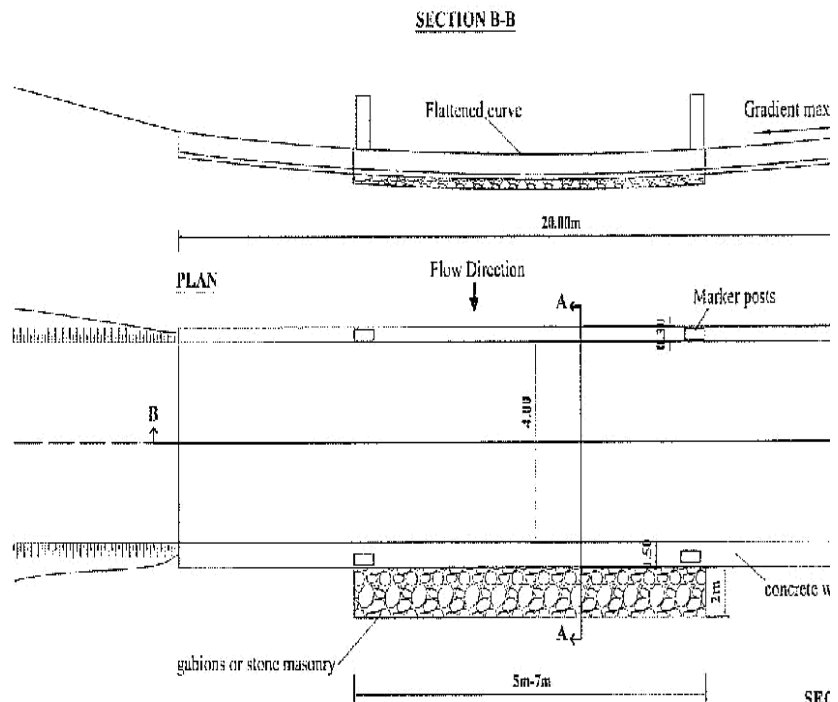

Material : All concrete Class 20/20 (1:2:4)

- 1 Concrete wall : 10m<sup>3</sup>
- 2 Concrete slab: 24m<sup>3</sup> or stone masonry
- 3 Concrete toe : 8m<sup>3</sup> or stone masonry
- 4 Gabions / mattress rock fill: 4.3m<sup>3</sup> or stone masonry
- 5 Gabions /mattress: 36m<sup>2</sup>
- 6 Marker posts - precast concrete: 4 no.
- 7 Excavation (slab + toes + gabions) 54.2m<sup>3</sup>

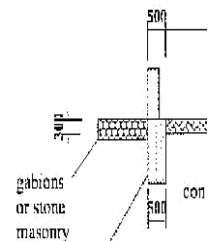

concrete wall > 1000t

**SECTION A-A**

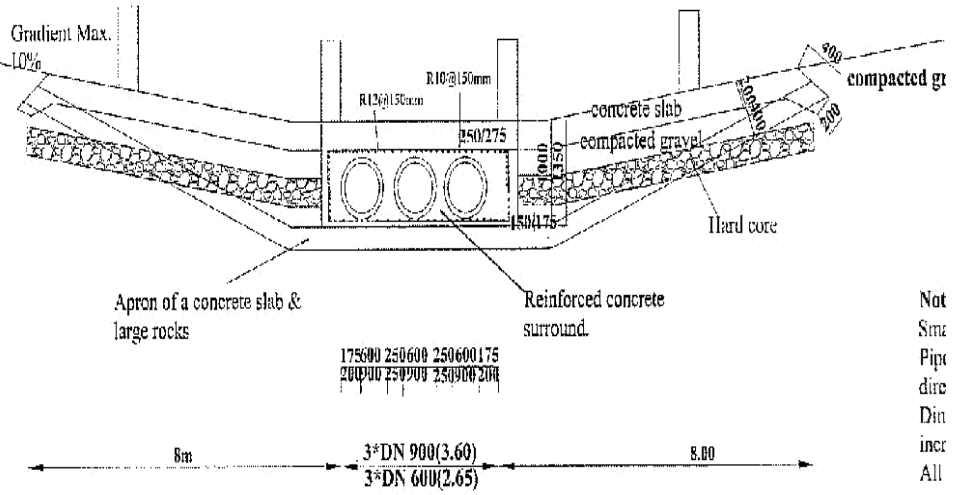

Not  
Sm  
Pipe  
dire  
Din  
incr  
All

**PLAN**

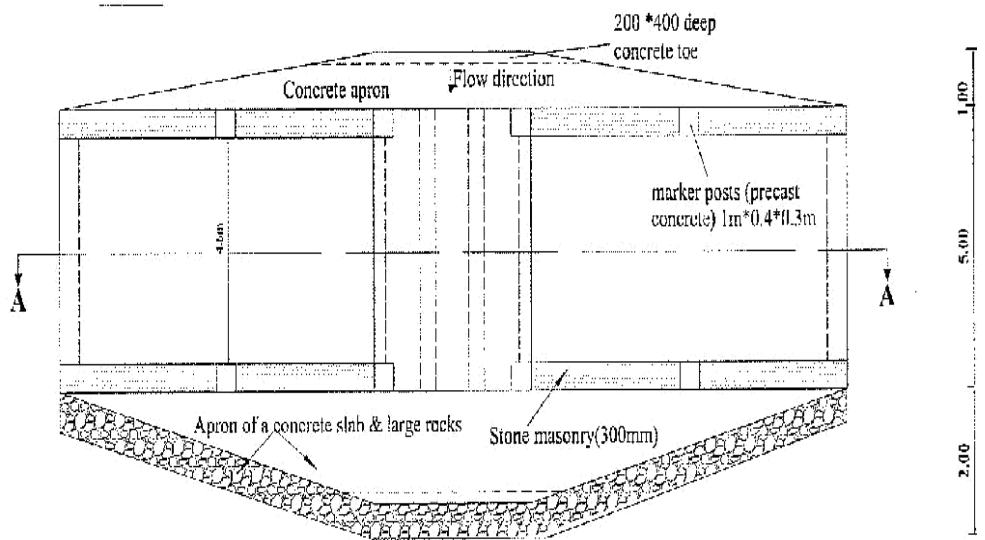



2. EDGE BEAM OF LARGE STONES

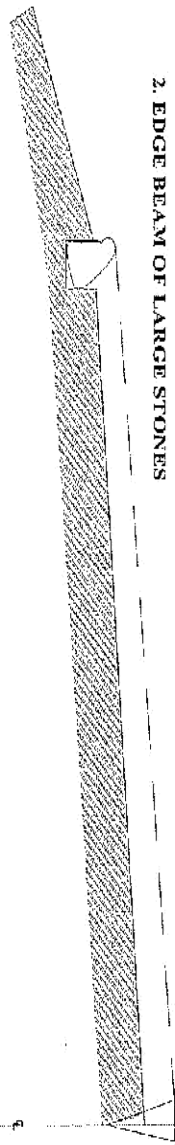

3. EDGE BEAM SECURED AND LARGE STONES LAID ON EDGE

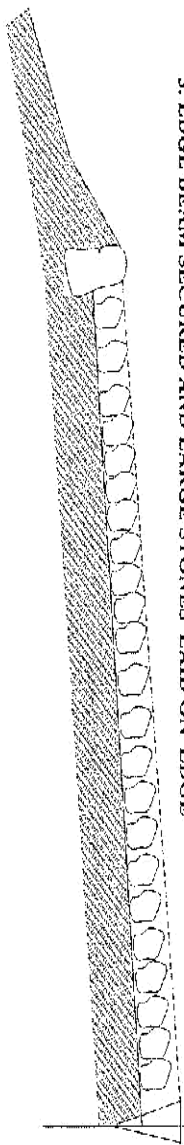

4. LARGE STONES WEDGED WITH SMALLER ONES THEN BLINDED

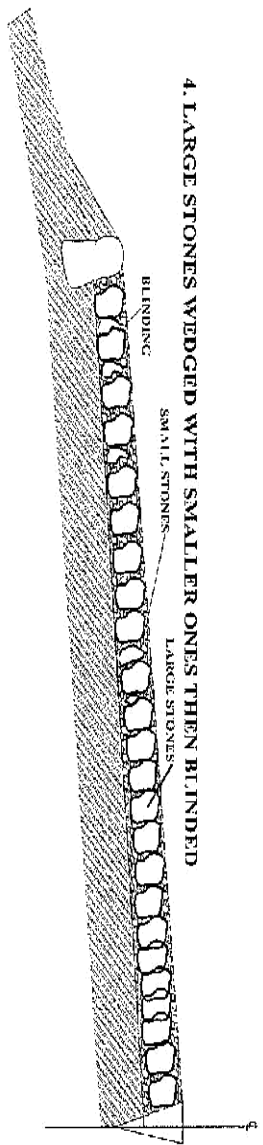

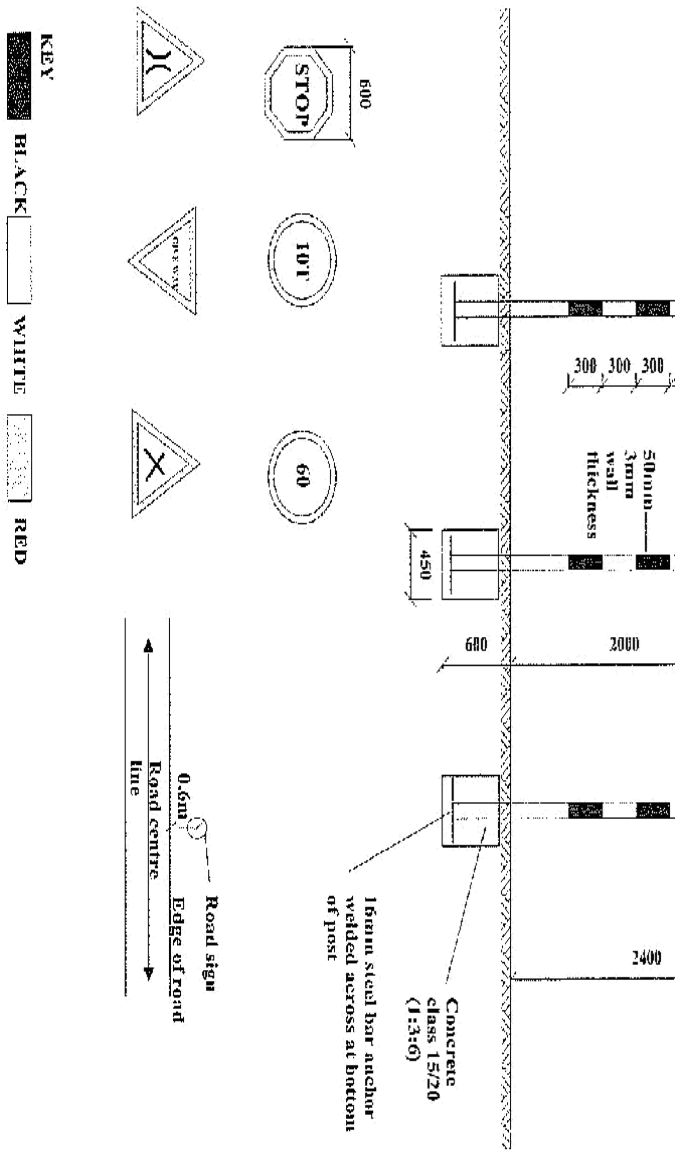

1. The type of sign required and their location shall be as shown on the Road Plan or as directed by the Engineer.
2. Sign plate to be 2mm thick mild steel plate
3. Sign post to be 50mm fixing clamps/brackets.
4. Sign plate to be fixed to steel tube by 5 Nos M10 bolts and 50mm fixing clamps/brackets.
5. Sign paints shall be reflective.
6. The sign plate and post shall be treated by applying two coats of lead red oxide paint before applying a priming and two finish coats of approved paints. Paints used shall have a hard, durable and glossy finish.

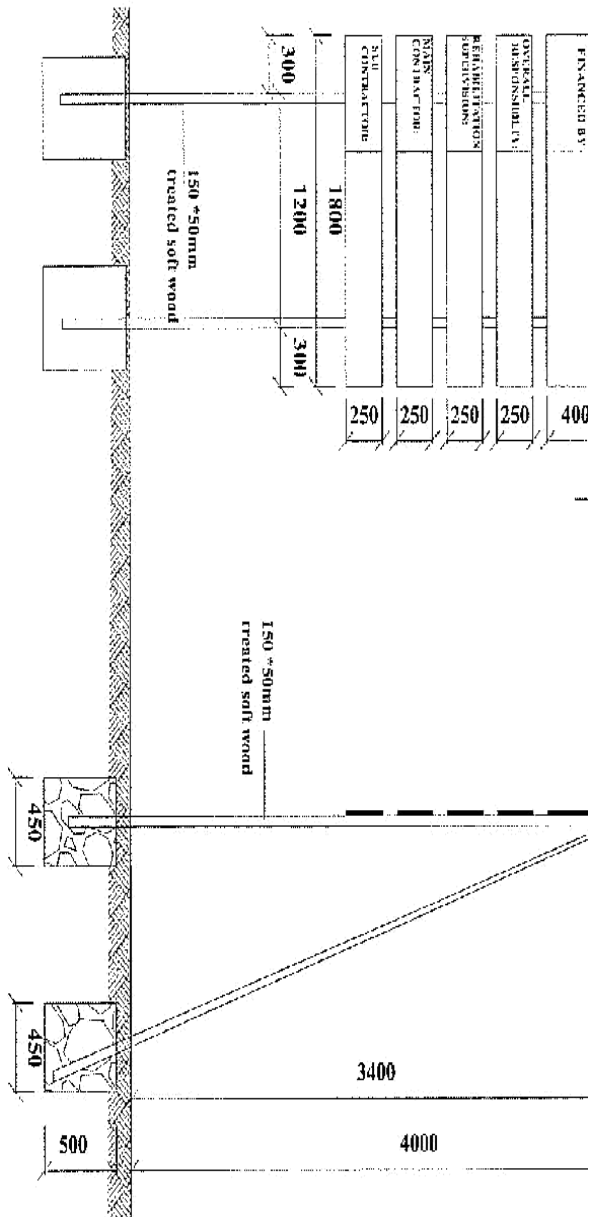

**NOTES**

1. The wording of the project sign board and the location to be as directed by the Engineer.
2. Materials to be used for fabrication of signboard shall be pressure impregnated treated softwood timber
3. Wording board posts to be attached to the posts with galvanised nails
4. Project board posts and struts to be embedded in concrete class 20/20(1:2:4)



## SECTION VII - BILLS OF QUANTITIES

1. The Bills of Quantities forms part of the Contract Documents and are to be read in conjunction with the Instructions to Bidders, Conditions of Contract Parts I and II, Specifications and Drawings.
2. The brief description of the items in the Bills of Quantities is purely for the purpose of identification, and in no way modifies or supersedes the detailed descriptions given in the conditions of Contract and Specifications for the full direction and description of work and materials.
3. The Quantities set forth in the Bills of Quantities are estimated, representing substantially the work to be carried out, and are given to provide a common basis for bidding and comparing of Bids. There is no guarantee to the Contractor that he will be required to carry out all the quantities of work indicated under any one particular item or group of items in the Bill of Quantities. The basis of payment shall be the Contractor's rates and the quantities of work actually done in fulfillment of his obligation under the Contract.
4. The prices and rates inserted in the Bills of Quantities will be used for valuing the work executed, and the Engineer will only measure the whole of the works executed in accordance with this Contract.
5. A price or rate shall be entered in ink against every item in the Bills of Quantities with the exception of items that already have Provisional sums affixed thereto. The bidders are reminded that no "nil" or "included" rates or "lump-sum" discounts will be accepted. The rates for various items should include discounts if any. Bidders who fail to comply will be disqualified.
6. Provisional sums (including Day works) in the Bills of Quantities shall be expended in whole or in part at the discretion of the Engineer.
7. The price and rates entered in the Bills of Quantities shall, except insofar as it is otherwise provided under the Contract, include all Constructional plant to be used, labour, insurance, supervision, compliance testing, materials, erection, maintenance of works, overheads and profits, taxes and duties together with all general risks, liabilities and obligations set out or implied in the Contract, transport, electricity and telephones, water, use and replenishment of all consumables, including those required under the contract by the Engineer and his staff.

Errors in the pricing of the Bills of Quantities will be corrected in accordance with Clause (28) of instructions to bidders.

Road Code	C406	Section Name			
<b>Package: KeRRA/011/EBU/39/RUN/22%2-23-20 21-006</b>					
Contractor	0				

<b>Bill of Quantities</b>					Page: 1	
Bill No.1	General: Office administration and overheads/Preliminaries				Project:	
Item No.	Description	Units	Quantity	Unit Bid Rate(Ksh)	Amount KSh	Technology
01-50-001	Clerical and Adminstrative Support	KS	1		200,000.00	LB-MB
01-60-005	Publicity Sign Boards	KS	1		35,000.00	LB-MB
					-	
					-	
					-	
					-	
					-	
					-	
					-	
					-	
					-	
					-	
					-	
					-	
					-	
					-	
					-	
					-	
					-	
					-	
					-	
					-	
					-	
<b>Total Carried Forward to Summary:</b>					235,000.00	

Road Code	C406	Section Name				
<b>Package: KeRRA/011/EBU/39/RUN/22%/2-23-20 21-006</b>						
Contractor	0					
<b>Bill of Quantities</b>					Page: 2	
Bill No.4	SITE CLEARANCE				Project:	
Item No.	Description	Units	Quantity	Unit Bid Rate(Ksh)	Amount KSh	Technology
04-50-003	Heavy Bush Clearing	M <sup>2</sup>	16000		-	LB
					-	
					-	
					-	
					-	
					-	
					-	
					-	
					-	
					-	
					-	
					-	
					-	
					-	
					-	
					-	
					-	
					-	
					-	
					-	
					-	
					-	
					-	
					-	
					-	
					-	
					-	
					-	
					-	
					-	
					-	
					-	
					-	
					-	
					-	
					-	
					-	
					-	
					-	
					-	
					-	
					-	
<b>Total Carried Forward to Summary:</b>					-	

Road Code	C406	Section Name				
Package: KeRRA/011/EBU/39/RUN/22%/2-23-20 21-006						
Contractor	0					
<b>Bill of Quantities</b>					Page: 3	
Bill No.8	CULVERT AND DRAINAGE WORKS				Project:	
Item No.	Description	Units	Quantity	Unit Bid Rate(Ksh)	Amount KSh	Technology
08-60-003	Culvert Cleaning- Partially blocked - 600mm	MT	60		-	LB
					-	
					-	
					-	
					-	
					-	
					-	
					-	
					-	
					-	
					-	
					-	
					-	
					-	
					-	
					-	
					-	
					-	
					-	
					-	
					-	
					-	
					-	
					-	
					-	
					-	
					-	
					-	
					-	
					-	
					-	
					-	
					-	
					-	
					-	
					-	
					-	
					-	
					-	
					-	
					-	
					-	
					-	
	<b>Total Carried Forward to Summary:</b>				-	





## SECTION VIII - STANDARD FORMS

### *LIST OF STANDARD FORMS*

- (ii) Form of Tender
- (iii) Appendix to Form of Tender
- (iv) Letter of Award
- (v) Form of Agreement
- (vi) Form of Tender Security
- (vii) Performance Bank Guarantee (unconditional)
- (viii) Tender Questionnaire
- (ix) Confidential Business Questionnaire
- (xi) Schedule of Materials;- Basic Prices
- (xiii) Schedule of Labour;- Basic Prices
- (xiv) Details of Sub-Contractors
- (xv) Certificate of Tenderer's Site visit
- (xvi) Form of Written Power of Attorney
- (xvii) Key Personnel
- (xviii) Completed Civil Works
- (xix) Schedule of Ongoing Projects
- (xx) Schedule of Plant and Equipment
- (xxi) Other Supplementary Information
- (xxii) Work Methodology
- (xxiii) Letter of Credit
- (xxiv) Declaration Form
- (xvi) Form of RB1

i.

**FORM OF TENDER**

(NOTE: The Appendix forms part of the Tender. Tenderers are required to fill all the blank spaces in this form of Tender and the Appendix)

NAME OF PROJECT: ROUTINE MAINTENANCE OF MUFU-KARUNGU (C406) ROAD

TO: **The Regional Manager,  
Kenya Rural Roads Authority,  
P. O. Box 2718,  
EMBU, KENYA**

Dear Sir,

Having examined the Conditions of Contract, Specifications, Bills of Quantities and Drawings for the execution of the above-named works we, the undersigned, offer to construct and install such works and remedy any defects therein in conformity with the Conditions of Contract, Specifications, Drawings, Bills of Quantities and Addenda for the sum of (Insert Amount in

Figures)..... (Insert Amount in Words).....  
.....  
.....

We undertake, if our tender is accepted, to **commence the works within fourteen (14) days** of receipt of the Engineer’s order to commence, and to complete and deliver the whole of the works comprised in the contract within the time stated in the special specification or in the Letter of Award.

We agree to abide by this tender for the period of ninety (90) from the date fixed for receiving the same and it shall remain binding upon us and may be accepted at any time before the expiration of that period.

We understand that you are not bound to accept the lowest or any tender you may receive.

On the basis of our previous experience we are fully experienced and competent in the type of work included in this Tender and we have adequate financial resources to carry out the works described within the period for completion. We are in a position to fulfil the contract for which we have tendered.

Dated this ..... Day of ..... 20 .....

Signature.....in the capacity of .....

Duly authorized to sign tenders on behalf of (Name of Tenderer) .....

.....

(Address of Tenderers).....



(Name of Witness).....

(Signature of Witness).....

(Address of Witness).....

(Occupation of Witness).....

(III) APPENDIX TO FORM OF TENDER

(This Appendix forms part of the Tender)

CONDITIONS OF CONTRACT	CLAUSE	AMOUNT
Bid Security (Bank/Insurance Guarantee Only)		N/A
Amount of Performance Security (Unconditional Bank Guarantee)	10.1	N/A
Submission of Performance Security		N/A
Programme to be submitted	14.1	Not later than 14 (fourteen) days after issuance of Order to Commence
Cash flow estimate to be submitted	14.3	Not later than 14 (fourteen) days after issuance of Order to Commence
Minimum amount of Contractors All Risk Insurance Cover	23.2	N/A
Submission of Contractors All Risk Insurance Cover		Submitted by the 15 <sup>th</sup> day from the date of award letter
Period for commencement, from Engineer's order to commence	41.1	14 days
Time for completion	43.1	90 Days
Advance Payment	60.12	No Advance payment
Amount of liquidated damages	47.1	N/A
Limit of liquidated damages	47.1	N/A
Defects Liability period	49.1	N/A
Percentage of Retention	60.3	N/A
Limit of Retention Money	60.3	N/A
Minimum amount of interim certificates	60.2	Kshs One Million (1,000,000)
Time within which payment to be made after Interim Payment Certificate signed by Engineer	60.10	90 (ninety) days
Time within which payment to be made after Final Payment Certificate signed by Engineer	60.10	Ninety (90) days
Appointer of Arbitrator	67(3)	The Chairman, Chartered Institute of Arbitrators - Kenya Branch.
Notice to Employer and Engineer	68.2	The Employer's address is: <b>The Director General, Kenya Rural Roads Authority, P.O. Box 48151 - 00100 NAIROBI</b> The Engineer's address is: <b>The General Manager - Maintenance, Kenya Rural Roads Authority, P.O. Box 48151 - 00100 NAIROBI</b>

Signature of Tenderer..... Date.....

**(IV)**

**FORM OF AGREEMENT**

THIS AGREEMENT is made on the .....day of ..... 2021 between the **KENYA RURAL ROADS (KeRRA)** of **P. O. Box 48151-00100, Nairobi**, Kenya hereinafter called "the Employer" of the one part And.....hereinafter called "the Contractor" of the other part.

WHEREAS the Employer is desirous that certain works should be executed, viz. Routine Maintenance of Mufu-Karungu (C406) Road and has accepted a Contract by the Contractor for the execution completion and maintenance of such works NOW THIS AGREEMENT WITNESSETH as follows:

In this agreement words and expressions shall have the same meanings as are respectively assigned to them in the Conditions of Contract hereinafter referred to.

The following documents shall be deemed to form and be read and construed as part of this Agreement, viz.:

- ❖ The Contract Agreement;
- ❖ The Letter of award by the Employer
- ❖ The Letter of Acceptance by the Contractor;
- ❖ The Form of Contract and Appendix to the Form of Contract;
- ❖ The Conditions of Contract Part I;
- ❖ The Conditions of Contract Part II;
- ❖ The Standard Specification for Road and Bridge Construction, 1986;
- ❖ The Special Specifications;
- ❖ The Drawings;
- ❖ The priced Bill of quantities;
- ❖ Conditions to the Contract and instructions to the Contractor;
- ❖ Other documents as may be agreed and listed

All aforesaid documents are hereinafter referred to as "The Contract".

In consideration of the payment to be made by the Employer to the Contractor, the Contractor hereby covenants with the Employer to execute, complete and maintain the works in conformity in all respects with the provisions of the Contract.

The Employer hereby covenants to pay the Contractor in consideration of the execution, completion and maintenance of the works for the Contract Price at the times and in the manner prescribed by the Contract.

IN WITNESS HEREOF the parties that have caused this Agreement to be excuted this .....day of ....., 2021.

SIGNED AND SEALED

In the presence of

- |             |   |           |                |
|-------------|---|-----------|----------------|
| 1. Employer | } | Name_____ | Signature_____ |
| 2. Witness  |   | Name_____ | Signature_____ |

SEALED with the Common Seal of

.....

In the presence of

- |                       |   |           |                |
|-----------------------|---|-----------|----------------|
| 1. Managing Director  | } | Name_____ | Signature_____ |
| 2. Director/Secretary |   | Name_____ | Signature_____ |

WHEREAS ..... (hereinafter called "the Tenderer") has submitted his tender dated ..... for the construction of ..... (name of Contract)

KNOW ALL PEOPLE by these presents that WE ..... having our registered office at .....(hereinafter called "the Bank"), are bound unto .....(hereinafter called "the Employer") in the sum of Kshs..... for which payment well and truly to be made to the said Employer, the Bank binds itself, its successors and assigns by these presents sealed with the Common Seal of the said Bank this ..... Day of .....20.....

THE CONDITIONS of this obligation are:

- 1. If after tender opening the tenderer withdraws his tender during the period of tender validity specified in the instructions to tenderers Or
2. If the tenderer, having been notified of the acceptance of his tender by the Employer during the period of tender validity:
(a) fails or refuses to execute the form of Agreement in accordance with the Instructions to Tenderers, if required; or
(b) fails or refuses to furnish the Performance Security, in accordance with the Instructions to Tenderers;
(c) Rejects a correction or an arithmetic error in the tender.

We undertake to pay to the Employer up to the above amount upon receipt of his first written demand, without the Employer having to substantiate his demand, provided that in his demand the Employer will note that the amount claimed by him is due to him, owing to the occurrence of one or both of the two conditions, specifying the occurred condition or conditions.

This guarantee will remain in force up to and including thirty (30) days after the period of tender validity, and any demand in respect thereof should reach the Bank not later than the said date.

[date] [signature of the Bank]
[witness] [seal]

(Amend accordingly if provided by the Insurance Company)

**(VI) PERFORMANCE BANK GUARANTEE (UNCONDITIONAL)**

To: \_\_\_\_\_(Name of Employer) \_\_\_\_\_(Date)  
\_\_\_\_\_ (Address of Employer)

Dear Sir,

WHEREAS \_\_\_\_\_(hereinafter called "the Contractor") has undertaken, in pursuance of Contract No. \_\_\_\_\_ dated \_\_\_\_\_ to execute \_\_\_\_\_ (hereinafter called "the Works");

AND WHEREAS it has been stipulated by you in the said Contract that the Contractor shall furnish you with a Bank Guarantee by a recognized bank for the sum specified therein as security for compliance with his obligations in accordance with the Contract;

AND WHEREAS we have agreed to give the Contractor such a Bank Guarantee:

NOW THEREFORE we hereby affirm that we are the Guarantor and responsible to you, on behalf of the Contractor, up to a total of Kshs. \_\_\_\_\_ (amount of Guarantee in figures) Kenya Shillings \_\_\_\_\_ (amount of Guarantee in words), and we undertake to pay you, upon your first written demand and without cavil or argument, any sum or sums within the limits of Kenya Shillings \_\_\_\_\_ (amount of Guarantee in words) as aforesaid without your needing to prove or to show grounds or reasons for your demand for the sum specified therein.

We hereby waive the necessity of your demanding the said debt from the Contractor before presenting us with the demand.

We further agree that no change, addition or other modification of the terms of the Contract or of the Works to be performed there under or of any of the Contract documents which may be made between you and the Contractor shall in any way release us from any liability under this Guarantee, and we hereby waive notice of any change, addition, or modification.

This guarantee shall be valid until the date of issue of the Certificate of Completion.

SIGNATURE AND SEAL OF THE GUARANTOR \_\_\_\_\_

Name of Bank \_\_\_\_\_

Address \_\_\_\_\_

Date \_\_\_\_\_

*(Amend accordingly if provided by Insurance Company)*

(VII)

TENDER QUESTIONNAIRE

Please fill in block letters.

1. Full names of tenderer

.....

2. Full address of tenderer to which tender correspondence is to be sent (unless an agent has been appointed below)

.....

3. Telephone number (s) of tenderer

.....

4. Email address of tenderer

.....

5. Name of tenderer's representative to be contacted on matters of the tender during the tender period

.....

6. Details of tenderer's nominated agent (if any) to receive tender notices. This is essential if the tenderer does not have his registered address in Kenya (name, address, telephone, telex)

.....

Signature of Tenderer

Make copy and deliver to : \_\_\_\_\_( *Name of Employer*)

You are requested to give the particulars indicated in Part 1 and 2.

You are advised that it is a serious offence to give false information on this Form.

Part 1 - General:

Business Name: .....

Location of Business Premises .....

Plot No. ....Street/Road .....

Postal Address.....Tel No. ....

Nature of Business

.....  
.....

Current Trade Licence No. ....Expiring Date .....

Maximum value of Business which you can handle at any one time:

Kshs.....

Name of your Bankers .....

Branch.....

Nationality.....Country of Origin .....

\*Citizenshipdetails .....

Part 2(a)- Registered Company:

Private or Public .....

State the nominal and issued capital of the company-

Nominal: Kshs. ....

Issued: Kshs. ....

Give details of all Directors as follows:

	Name	Nationality	Citizenship Details●	Shares
1.	.....	.....	.....	.....
2.	.....	.....	.....	.....



3. ....

4. ....

Part 2 (b)- Interest in the Firm:

Is there any person / persons in the Ministry of Transport and Infratsructure or Kenya Rural Roads Authority who has interest in this firm? Yes /No\*\*

Date: ..... Signature of Tenderer.....

\*\* Delete as necessary

- Attach proof of citizenship (Compulsory)



**CERTIFICATE OF TENDERER'S VISIT TO SITE**

This is to certify that

[Name/s].....

Being the authorized representative/ Agent of [Name of Tenderer]

.....  
.....  
.....

Participated in the organized inspection visit of the site of the works for the  
**Routine Maintenance of Mufu-Karungu (C406) Road**

..... day of.....20.....

Signed.....

(Employer's Representative)

Peter Chigiri Mwarabu  
Procurement Officer  
KeRRA Embu

.....

**NOTE: This form is to be completed at the time of the organized site visit.**

**(IX)**

**FORM OF WRITTEN POWER-OF-ATTORNEY**

The Tenderer shall state here below the name(s) and address of his representative(s) who is/are authorized to receive on his behalf correspondence in connection with the Tender.

.....  
(Name of Tenderer's Representative in block letters)

.....  
(Address of Tenderer's Representative)

.....  
(Signature of Tenderer's Representative)

Alternate:

.....  
(Name of Tenderer's Representative in block letters)

.....  
(Address of Tenderer's Representative)

.....  
(Signature of Tenderer's Representative)

*\*To be filled by all Tenderers.*

(X)

**KEY PERSONNEL**

DESIGNATION	NAME	NATIONALITY	SUMMARY OF QUALIFICATION AND EXPERIENCE		
			QUALIFICATION	GENERAL EXPERIENCE	RELEVANT EXPERIENCE
				YRS	YRS
<b>Headquarters</b> Partner/Director or other key staff (give designation)					
<b>Site Office</b> Site Agent					
<b>Other key staff</b>  Foremen					

**Note:** The Tenderer shall list in this schedule the key personnel he will employ from the Contractor's headquarters and from the Contractor's site office to direct and execute the work together with their qualifications, experience, position held and nationality in accordance with Clause 15.2 and 16.3 of the Conditions of Contract Part II (where required, use separate sheets to add extra data for column 4).

Tenderers shall be required to attach CVs and academic certificates of all key staff

I certify that the above information is correct.

.....  
(Title)

.....  
(Signature)

.....  
(Date)

**(XI) SCHEDULE OF COMPLETED CIVIL WORKS CARRIED OUT  
BY THE TENDERER IN THE LAST THREE YEARS**

DESCRIPTION OF WORKS	VALUE OF WORKS (Kshs) *	YEAR COMPLETED / REMARKS

*I certify that the above works were successfully carried out by this Tenderer (Attach Completion Certificates)*

Signature of Tenderer: .....

Date: .....

\* Value in Kshs using Central Bank of Kenya mean exchange rate at a reference date 7 days before the date of Tender Opening

**(XII) SCHEDULE OF ONGOING PROJECTS**

DESCRIPTION OF WORK AND CLIENT	CONTRACT PERIOD	DATE OF COMMENCEMENT	DATE OF COMPLETION	TOTAL VALUE OF WORKS (KSHS.)	PERCENTAGE COMPLETED TO DATE

I certify that the above Civil Works are being carried out by us and that the above information is correct.

.....  
(Title)

.....  
(Signature)

.....  
(Date)

**(XIII) SCHEDULE 5: MAJOR ITEMS OF CONSTRUCTION PLANT AND EQUIPMENT**

Date of Arrival on Project (Days after commencement))						
Power Rating						
Owned/ Leased/ Imported						
Source						
Estimated CIF Mombasa Value (If to be Imported)						
Capacity T or m cu						
New or Used						
Year of Manufacture						
No. of Each						
Description Type, Model, Make						

*The Tenderer shall enter in this schedule all major items of plant and equipment which he proposes to bring to site. Only reliable plant in good working order and suitable for the work required of it shall be shown on this Schedule.*

*I certify that the above information is correct.*

Signature of Tenderer: ..... Date: .....

Name of Signatory: .....

**(XIV) OTHER SUPPLEMENTARY INFORMATION**

1. Financial reports for the last three years, balance sheets, profit and loss statements, auditors' reports etc. List them below and attach copies.

.....  
 .....  
 .....

2. Evidence of access to financial resources to meet the qualification requirements. Cash in hand, lines of credit etc. List below and attach copies of supporting documents (bank to fill attached form).

.....  
 .....  
 .....

3. Name, address, telephone, telex, fax numbers of the Tenderer's Bankers who may provide reference if contacted by the Employer.

.....  
 .....  
 .....

- Submit copies of audited profit and loss statements and balance sheet for the last two calendar years and estimated projection for the next two years with certified English translation where appropriate.
- Give turnover figures for each of the last two (2) financial years. Quote in millions and decimal thereof.

Type of \Work	Year 2019	Year 2020
	Kshs.	Kshs.
Roadworks		
Other civil engineering works		
Other (specify)		
Total		

**SUMMARY OF ASSETS AND LIABILITIES OF THE AUDITED FINANCIAL STATEMENTS OF THE LAST TWO (2) FINANCIAL YEARS**

	Year 2019	Year 2020
	Kshs.	Kshs.
1. Total Assets		
2. Current Assets		
3. Bank credit Line Value		
4. Total Liabilities		
5. Current Liabilities		
6. Net worth (1-4)		
7. Working capital (2+3-4)		

❖ Name/ Address of Commercial Bank providing credit line



.....  
.....

❖ Total amount of credit line Kshs . .....

Attach certified copies of financial bank statements of the last one year.

Attach a certified copy of Undertaking of the Bank to providing the credit.

**4. Information on current litigation in which the Tenderer is involved.**

OTHER PARTY (IES)	CAUSE OF DISPUTE	AMOUNT INVOLVED (KSHS)

I certify that the above information is correct.

.....  
*Name/Title*

.....  
*Signature*

.....  
*Date*

## (XV) WORK METHODOLOGY

Give a brief description of how you intend to carry out the work including traffic management, quality assurance of works and any designs to be carried out by the Bidder, not more than five (5) pages.

(XVI) LETTER OF CREDIT

To

**The Director General,  
Kenya Rural Roads Authority,  
P.O. Box 48151 - 00100  
NAIROBI**

**RE: LINE OF CREDIT FOR (CONTRACT DETAILS)**

Reference is made to inquiry from our Customer ..... of P.O. Box ..... in regard to line of Credit for financing above tender. We wish to state as following.

1. M/S .....(name of tender) has satisfactorily conducted an account dominated in Kenya Shillings with us for a period of more than one year.
2. Currently the above named Customer enjoys
  1. A Bank Overdraft facility of Kshs .....
  2. A bank loan of Kshs .....
3. As per the prudential norms for Financing which MUST be fulfilled by our customer, we are in a position to provide a line of credit to M/s ..... (tenderer name) for Kshs .....

This information is given in strict confidence, and without any guarantee or liability on the part of the bank or any of its officers.

Yours Faithfully

Bank Authorised Signatory

(XVII) DECLARATION FORM

Date \_\_\_\_\_

To  
**The Director General,  
Kenya Rural Roads Authority,  
P.O. Box 48151 - 00100  
NAIROBI**

The tenderer i.e. (name and address) \_\_\_\_\_

\_\_\_\_\_ declare the following:

- a) Has not been debarred from participating in public procurement.
- b) Has not been involved in and will not be involved in corrupt and fraudulent practices regarding public procurement.

\_\_\_\_\_  
Name/Title

\_\_\_\_\_  
Signature

\_\_\_\_\_  
Date

(To be signed by authorized representative and officially stamped)

**(XVIII) TENDER-SECURING DECLARATION FORM**

(The Bidder shall complete this form in accordance with the instructions indicated)

Date of Bid submission: ..... Tender No: .....

To: Director General, Kenya Rural Roads Authority (Employer).

We, the undersigned, declare that:

1. We understand that according to your conditions, bids must be supported by a Bid – Securing Declaration.
2. We accept that we will be suspended from being eligible for bidding in any contract with the Employer for the period of time of **24 Months** starting on **June 2019**, if we are in breach of our obligation(s) under the bid conditions, because we; -
  - a. Have withdrawn our Bid during the period of bid validity specified in the Bidding data sheet; or
  - b. Having been notified of the acceptance of our Bid by the Employer during the period of bid validity;
    - i. Fail or refuse to execute the contract, if required, or
    - ii. Fail or refuse to furnish the performance security, in accordance with the
3. We understand that this Bid Securing Declaration shall expire if we are not the successful Bidder, upon the earlier of
  - i. Our receipt of a copy of your notification of the name of the successful Bidder; or
  - ii. Twenty-eight days after the expiration of the Tender.
4. We understand that if we are a joint Venture, the Bid Securing Declaration must be in the name of the Joint Venture that submit, the bid and if the joint venture has not been legally constituted at the time of bidding, the Bid-Securing Declaration shall be in the names of all future partners as named in the letter of intent.

Signed: ..... in the capacity of .....

Name: ..... (Complete name of person signing this form)

Duly authorized to sign the bid for and on behalf of..... (Name of Bidder)

Date on ..... day of.....

Stamped: .....

**(XIX) LETTER OF NOTIFICATION OF AWARD**

[To be issued by in Official Kenya Rural Roads Letterhead by the Head of Procurement and shall detail

Address of the Successful Bidder

Tender Name

Tender Number

It shall as part of its contents

Notify that the contract/s stated below under the above mentioned tender have been awarded to you.

---

---

1. Please acknowledge receipt of this letter of notification signifying your acceptance.
2. The contract/contracts shall be signed by the parties within 30 days of the date of this letter but not earlier than 14 days from the date of the letter.
3. You may contact the officer(s) whose particulars appear below on the subject matter of this letter of notification of award.

SIGNED FOR ACCOUNTING OFFICER

REPUBLIC OF KENYA  
PUBLIC PROCUREMENT ADMINISTRATIVE REVIEW BOARD

APPLICATION NO.....OF.....20.....

BETWEEN

.....APPLICANT

AND

.....RESPONDENT (*Procuring Entity*)

Request for review of the decision of the..... (*Name of the Procuring Entity*) of  
.....dated the...day of .....20.....in the matter of Tender No.....of  
.....20...

**REQUEST FOR REVIEW**

I/We.....,the above named Applicant(s), of address: Physical  
address.....Fax No.....Tel. No.....Email ....., hereby request the Public  
Procurement Administrative Review Board to review the whole/part of the above mentioned  
decision on the following grounds , namely:-

- 1.
- 2.
- etc.

By this memorandum, the Applicant requests the Board for an order/orders that: -

- 1.
- 2.
- etc

SIGNED .....(Applicant)

Dated on.....day of ...../...20...

**FOR OFFICIAL USE ONLY**

Lodged with the Secretary Public Procurement Administrative Review Board on ..... day of  
.....20.....

SIGNED  
Board Secretary

