



# KENYA RURAL ROADS AUTHORITY

UPPER WESTERN REGION  
BUNGOMA OFFICE

(KIMILILI CONSTITUENCY)

## ROUTINE MAINTENANCE AND SPOT IMPROVEMENT OF;

**ROAD NUMBER** : UNCL

**ROAD NAME** : C42 RASHID-CHEBUKWABI.

**TENDER NUMBER** : KeRRA/011/BGM/KML/10%/39/20/21-083

### BID DOCUMENT

- **SECTION I** : INVITATION TO TENDER
- **SECTION II** : INSTRUCTIONS TO BIDDERS
- **SECTION III** : QUALIFICATION CRITERIA
- **SECTION IV** : CONDITIONS OF CONTRACT
- **SECTION V** : APPENDIX TO FORM OF AGREEMENT
- **SECTION VI** : STANDARD FORMS
- **SECTION VII** : CONTRACTOR'S EVALUATION CHECKLIST
- **SECTION VIII** : SPECIFICATIONS, DRAWINGS AND BILLS OF QUANTITIES

**APRIL, 2021**

DIRECTOR (ROAD ASSET MANAGEMENT),  
KENYA RURAL ROADS AUTHORITY,  
P.O. BOX 48151-00100,  
NAIROBI.

DIRECTOR GENERAL,  
KENYA RURAL ROADS AUTHORITY,  
P.O. BOX 48151-00100,  
NAIROBI.

**STANDARD TENDER DOCUMENT  
FOR  
PROCUREMENT OF WORKS**

- **ROUTINE MAINTENANCE AND SPOT IMPROVEMENT WORKS**

# TABLE OF CONTENTS

PAGE No.

---

<b>SECTION I: INVITATION TO TENDER.....</b>	<b>3</b>
<b>SECTION II: INSTRUCTIONS TO TENDERERS.....</b>	<b>4</b>
<b>SECTION III: QUALIFICATION CRITERIA.....</b>	<b>12</b>
<b>SECTION IV: CONDITIONS OF CONTRACT.....</b>	<b>11</b>
<b>SECTION V: APPENDIX TO FORM OF AGREEMENT.....</b>	<b>26</b>
<b>SECTION VI: STANDARD FORMS.....</b>	<b>29</b>
<b>SECTION VII: CONTRACTOR'S EVALUATION CHECKLIST.....</b>	<b>49</b>
<b>SECTION VIII: SPECIFICATIONS, DRAWINGS AND BILLS OF QUANTITIES.....</b>	<b>49</b>

## SECTION I: INVITATION TO TENDER

**Tender No.** : KeRRA/011/BGM/KIML/10%/39/20/21-083

**Tender Name:** Routine Maintenance and Spot Improvement of  
**C42Rashid-Chebukwabi**

- 1.1 The Regional Director Kenya Rural Roads Authority, Upper Western Region, invites sealed tenders for the routine maintenance and spot improvement of Rashid – Chebukwabi (R40).
- 1.2 Interested eligible bidders may obtain further information and inspect tender documents from **29<sup>th</sup> April 2021** to **7<sup>th</sup> May 2021** during official working hours between Monday and Friday at Kenya Rural Roads Authority (KeRRA) Upper Western Region, Bungoma Office, and P.O Box 1473- 50200 Bungoma. The Office is located in Kanduyi Centre off Webuye - Malaba Road.
- 1.3 The tender document can also be downloaded freely from KeRRA [website](http://www.kerra.go.ke) [www.kerra.go.ke](http://www.kerra.go.ke) as from 30<sup>th</sup> April,2021
- 1.4 Prices quoted should be net inclusive of all taxes, must be in Kenya shillings and shall remain valid for **120** days from the closing date of tender.
- 1.5 Subsequent to presidential directive on COVID-19 Pandemic there shall be no pre-tender site visit, bidders are advised to make their own arrangements to familiarize themselves with the site before of their bids.
- 1.6 Completed tender documents are to be enclosed in plain sealed envelopes marked with Tender name and reference number and deposited in the Tender Box at KeRRA Bungoma Office or to be addressed to Regional Deputy Director KeRRA Upper Western Region, P.O Box 1473-50200, and Bungoma so as to be received on or before **Friday, 7<sup>th</sup> May 2021** at 10.00am.
- 1.7 Tenders will be opened immediately thereafter in the presence of the bidders or their representatives who choose to attend at KeRRA Bungoma Office.

**REGIONAL DEPUTY DIRECTOR (UPPER WESTERN)**

## **SECTION II: INSTRUCTIONS TO TENDERERS**

### **TABLE OF CONTENTS**

<b>CLAUSE</b>	<b>PAGE.</b>
1. GENERAL	6
2. TENDER DOCUMENTS	8
3. PREPARATION OF TENDERS	8
4. SUBMISSION OF TENDERS	9
5. TENDER OPENING AND EVALUATION	10
6. AWARD OF CONTRACT	12

## INSTRUCTIONS TO TENDERERS

1. General
  - 1.1 The Employer as defined in the Appendix to Form of Agreement invites tenders for Works Contract as described in the tender documents. The successful Tenderer will be expected to complete the Works by the Intended Completion Date specified in the said Appendix.
  - 1.2 Tenderers shall include the following information and documents with their tenders, unless otherwise stated:
    - (a) Certified copy of Certificate of Incorporation;
    - (b) Certified copy of Registration with NCA 8;
    - (c) Certified copy of Valid NCA Contractors Annual practicing license;
    - (d) Certified copy of KRA Valid Tax Compliance Certificate;
    - (e) Certified copy of KRA VAT and PIN Registration Certificate;
    - (f) Certified copy of most recent CR12, valid for immediate previous 12 months;
    - (g) Experience in works of a similar nature and size for each of the last five years;
    - (h) Equipment holding supported by relevant documentation;
    - (i) Current Trading License and principal place of Business;
    - (j) Proof of having Bank Account in the Tenderer's name;
    - (k) Duly filled confidential Business Questionnaire;
    - (l) Duly filled and Signed Form of Tender and Appendix;
    - (m) Duly filled Bills of Quantities;
    - (n) Well serialized pages by the bidder.
  - 1.3 Tenderer shall bear all the costs associated with the preparation and submission of his tender and the employer will be in no case be responsible or liable for those costs.
  - 1.4 The Tenderer, at the Tenderer's own responsibility and risk, is encouraged to visit and examine the Site of the Works and its surroundings, and obtain all information that may be necessary for preparing the tender and entering into a contract for construction of the Works. The costs of visiting the Site shall be at the Tenderer's own expense.
  - 1.5 The procurement entity's employees, committee members, board members and their relative (spouse and children) are not eligible to participate in the tender.
  - 1.6 The price to be charged for the hard copy tender document shall not exceed **Kshs.1,000 /=-** but downloaded freely from KeRRA website ([www.kerra.go.ke](http://www.kerra.go.ke)) tender portal.
  - 1.7 The procuring entity shall allow the Tenderer to review the tender document free of charge before purchase.
  - 1.8 The Engineer's cost estimate for these works is **Kshs. 3,175,000.00 (Kenya Shillings Three Million, One Hundred and Seventy Five Thousand Only)**.

## **2. Tender Documents**

- 2.1 The complete set of tender documents comprises the documents listed here below and any addenda issued in accordance with clause 2.4 here below:-
- (a) Instructions to Tenderers
  - (b) Form of Tender
  - (c) Conditions of Contract and Appendix to Form of Agreement
  - (d) Specifications
  - (e) Drawings
  - (f) Bills of Quantities
  - (g) Other materials required to be filled and submitted in accordance with these Instructions and Conditions
- 2.2 The Tenderer shall examine all instructions, forms and specifications in the tender documents. Failure to furnish all information required by the tender documents may result in rejection of his tender.
- 2.3 Prospective Tenderer making inquiries of the tendering documents may notify the Employer in writing or by cable, telex or facsimile at the address indicated in the letter of invitation to tender. The Employer will respond to any request for clarification received earlier than seven [7] days prior to the deadline for submission of tenders. Copies of the Employer's response will be forwarded to all persons issued with tendering documents, including a description of the inquiry, but without identifying its source.
- 2.4 Before the deadline for submission of tenders, the Employer may modify the tendering documents by issuing addenda. Any addendum thus issued shall be part of the tendering documents and shall be communicated in writing or by cable, telex or facsimile to all Tenderers. Prospective Tenderers shall acknowledge receipt of each addendum in writing to the Employer.
- 2.5 To give prospective Tenderers reasonable time in which to take an addendum into account in preparing their tenders, the Employer shall extend, as necessary, the deadline for submission of tenders in accordance with clause 4.2 here below.

## **3. Preparation of Tenders**

- 3.1 All documents relating to the tender and any correspondence shall be in English Language.
- 3.2 The tender submitted by the Tenderer shall comprise the following:-

- (a) The Tender;
  - (b) Priced Bill of Quantities
  - (c) Any other materials required to be completed and submitted by Tenderers.
- 3.3 The Tenderer shall fill in rates and prices for all items of the Works described in the Bill of Quantities. Items for which no rate or price is entered by the Tenderer will not be paid for when executed and shall be deemed covered by the other rates and prices in the Bill of Quantities. All duties, taxes and other levies payable by the Contractor under the Contract, as of 30 days prior to the deadline for submission of tenders, shall be included in the tender price submitted by the Tenderer.
- 3.4 The rates and prices quoted by the Tenderer shall not be subject to any adjustment during the performance of the Contract.
- 3.5 The unit rates and prices shall be in Kenya Shillings.
- 3.6 Tenders shall remain valid for a period of **One Hundred and Twenty (120)** days from the date of submission. However in exceptional circumstances, the Employer may request that the Tenderers extend the period of validity for a specified additional period. The request and the Tenderers' responses shall be made in writing.
- 3.7 The Tenderer shall prepare one original of the documents comprising the tender documents as described in these Instructions to Tenderers.
- 3.8 The original shall be typed or written in indelible ink and shall be signed by a person or persons duly authorized to sign on behalf of the Tenderer. All pages of the tender where alterations or additions have been made shall be initialed by the person or persons signing the tender.
- 3.9 Clarification of tenders shall be requested by the tenderer to be received by the procuring entity not later than 7 days prior to the deadline for submission of tenders.
- 3.10 The procuring entity shall reply to any clarifications sought by the tenderer within **7 days** of receiving the request to enable the tenderer to make timely submission of its tender.

#### **4. Submission of Tenders**

- 4.1 The tender duly filled and sealed in an envelope shall;-
- [a] be addressed to the Employer at the address provided in the invitation to tender;
  - [b] bear the name and identification number of the Tender as defined in the invitation to tender; and



- [c] Provide a warning not to open before the specified time and date for tender opening.
- 4.2 Tenders shall be delivered to the Employer at the address specified above not later than the time and date specified in the invitation to tender.
- 4.3 The tenderer shall not submit any alternative offers unless they are specifically required in the tender documents. Only one tender may be submitted by each tenderer. Any tenderer who fails to comply with this requirement will be disqualified.
- 4.4 Any tender received after the deadline for opening tenders will be returned to the tenderer un-opened.
- 4.5 The Employer may extend the deadline for submission of tenders by issuing an amendment in accordance with sub-clause 2.5 in which case all rights and obligations of the Employer and the Tenderers previously subject to the original deadline will then be subject to the new deadline.

## **5. Tender Opening and Evaluation**

- 5.1 The tenders will be opened in the presence of the Tenderers' representatives who choose to attend at the time and in the place specified in the invitation to tender.
- 5.2 The Tenderers' names, the total amount of each tender and such other details as may be considered appropriate, will be announced at the opening by the Employer. Minutes of the tender opening, including the information disclosed to those present will also be prepared by the Employer.
- 5.3 Information relating to the examination, clarification, evaluation and comparison of tenders and recommendations for the award of the Contract shall not be disclosed to Tenderers or any other persons not officially concerned with such process until the award to the successful Tenderer has been announced. Any effort by a Tenderer to influence the Employer's officials, processing of tenders or award decisions may result in the rejection of his tender.
- 5.4 Tenders determined to be substantially responsive will be checked for any arithmetic errors. Errors will be corrected as follows:
  - (a) where there is a discrepancy between the amount in figures and the amount in words, the amount in words will prevail; and
  - (b) Where there is a discrepancy between the unit rate and the line item total resulting from multiplying the unit rate by the quantity, the unit rate as quoted will prevail, unless in the opinion of the Employer's representative, there is an obvious typographical error, in which case the adjustment will be made to the entry containing that error.

- (c) In the event of a discrepancy between the tender amount as stated in the Form of Tender and the corrected tender figure in the main summary of the Bill of Quantities/Quotation, the amount as stated in the Form of Tender shall prevail.
  - (d) The Error Correction Factor shall be computed by expressing the difference between the tender amount and the corrected tender sum as a percentage of the Corrected Builder's Work (i.e. corrected tender sum less P.C. and Provisional Sums).
  - (e) The Error Correction Factor shall be applied to all Builder's Work (as a rebate or addition as the case may be) for the purposes of valuations for Interim Certificates and valuation of variations.
  - (f) The amount stated in the tender will be adjusted in accordance with the above procedure for the correction of errors and with concurrence of the Tenderer, shall be considered as binding upon the Tenderer. If the Tenderer does not accept the corrected amount, the tender may be rejected and the Tender Security forfeited.
- 5.5 The tender evaluation committee shall evaluate the tender within 30 days of the validity period from the date of opening the tender.
- 5.6 Contract price variations shall not be allowed for contracts not exceeding one year (12 months)
- 5.7 Where contract price variation is allowed, the valuation shall not exceed 25% of the original contract price.
- 5.8 Price variation requests shall be processed by the procuring entity within 30 days of receiving the request.
- 5.9 To assist in the examination, evaluation, and comparison of tenders, the Employer at his discretion, may request [in writing] any Tenderer for clarification of the tender, including breakdowns of unit rates. The request for clarification and the response shall be in writing or by cable, telex or facsimile but no change in the tender price or substance of the tender shall be sought, offered or permitted.
- 5.10 The Tenderer shall not influence the Employer on any matter relating to his tender from the time of the tender opening to the time the Contract is awarded. Any effort by the Tenderer to influence the Employer or his employees in his decision on tender evaluation, tender comparison or Contract award may result in the rejection of the tender.

## **6. Award of Contract**

- 6.1 The award of the Contract will be made to the Tenderer who has offered the lowest evaluated tender price.
- 6.2 Notwithstanding the provisions of clause 6.1 above, the Employer reserves the right to accept or reject any tender and to cancel the tendering process and reject all tenders at any time prior to the award of Contract without thereby incurring any liability to

the affected Tenderer or Tenderers or any obligation to inform the affected Tenderer or Tenderers of the grounds for the action.

- 6.3 The Tenderer whose tender has been accepted will be notified of the award prior to expiration of the tender validity period in writing or by cable, telex or facsimile. This notification (hereinafter and in all Contract documents called the “Letter of Acceptance”) will state the sum [hereinafter and in all Contract documents called the “Contract Price” which the Employer will pay the Contractor in consideration of the execution, completion and maintenance of the Works by the Contractor as prescribed by the Contract. The contract shall be formed on the parties signing the contract. At the same time the other tenderers shall be informed that their tenders have not been successful.
- 6.4 The Contract Agreement will incorporate all agreements between the Employer and the successful Tenderer. It will be signed by the Employer and sent to the successful Tenderer, within 30 days following the notification of award. Within 21 days of receipt, the successful Tenderer will sign the Agreement and return it to the Employer.
- 6.5 Within 21 days after receipt of the Letter of Acceptance, the successful Tenderer shall deliver to the Employer a Performance Security amount stipulated in the Appendix to Conditions of Contract.
- 6.6 The parties to the contract shall have it signed within 30 days from the date of notification of contract award unless there is an administrative review request.
- 6.7 The procuring entity may at any time terminate procurement proceedings before contract award and shall not be liable to any person for the termination.
- 6.8 The procuring entity shall give prompt notice of the termination to the tenderers and on request give its reasons for termination within 14 days of receiving the request from any tenderer.

## **7. Corrupt and fraudulent practices**

- 7.1 The procuring entity requires that the tenderer observes the highest standard of ethics during the procurement process and execution of the contract. A tenderer shall sign a declaration that he has not and will not be involved in corrupt and fraudulent practices.
- 7.2 The procuring entity will reject a tender if it determines that the tenderer recommended for award has engaged in corrupt and fraudulent practices in competing for the contract in question.
- 7.3 Further a tenderer who is found to have indulged in corrupt and fraudulent practices risks being debarred from participating in public procurement in Kenya.

### SECTION III: QUALIFICATION CRITERIA

Qualification Criteria			Compliance Requirements	Documentation
No.	Subject	Requirement	Single Entity	Submission Requirements
<b>1. Eligibility</b>				
1.1	<b>Eligibility</b>	Nationality in accordance with confidential business Questionnaire in the standard forms	Must meet requirement	Refer to standard form section 7
1.2	<b>Incorporation &amp; Registration</b>	<p>Pursuant to sub clause 1.2 the following shall be provided;</p> <ul style="list-style-type: none"> <li>- Certified Copy of Certificate of incorporation to show that the applicant is a registered company and legally authorised to do business in Kenya.</li> <li>- Proof of registration with the National Construction Authority Category NCA 8 and above for Road Works and a valid NCA practising licence as at closing date of tender submission.</li> </ul>	Must meet requirement	Refer to standard form section 7

Qualification Criteria			Compliance Requirements	Documentation
No.	Subject	Requirement	Single Entity	Submission Requirements
2.1	<b>History of Non-Performing Contracts</b>	Non-performance of a contract did not occur within the last <b>three (3)</b> years prior to the deadline for application submission based on all information on fully settled disputes or litigation. A fully settled dispute or litigation is one that has been resolved in accordance with the Dispute Resolution Mechanism under the respective contract, and where all appeal instances available to the applicant have been exhausted.	Must meet requirement by itself or as party to past	Refer to standard form section 7
2.2	<b>Pending Litigation</b>	All pending litigation shall in total not represent more than fifty per cent (50%) of the Applicant's net worth and shall be treated as resolved against the Applicant.	Must meet requirement by itself or as party to past	Refer to standard form section 7
3.1	<b>Financial Performance</b>	Submission of audited balance sheets for the last three [3] years to demonstrate Capacity to have a <b>cash flow amount of minimum Kshs 500,000.00</b> equivalent working capital.	Must meet requirement	Refer to standard form section 7
3.2	<b>Average Annual Construction Turnover</b>	Minimum average annual construction turnover of <b>Kshs. 1,000,000</b> [Kenya Shillings One Million], calculated as total certified payments of similar works received for contracts in progress or completed, within the last <b>three</b> [3] years	Must meet requirement	Refer to standard form section 7
4.1	<b>General Construction Experience</b>	Experience under construction contracts in the role of contractor, subcontractor, or management contractor for at least the last <b>One</b> [1] year prior to the applications submission deadline	Must meet requirement	Refer to standard form section 7

Qualification Criteria			Compliance Requirements	Documentation
No.	Subject	Requirement	Single Entity	Submission Requirements
4.2(a)	<b>Specific Construction Experience</b>	Participation as contractor, management contractor or subcontractor, <b>in at least two (2) contracts within the last five (5) years, each with a value of at least KShs.1 Million (Kenya Shillings One Million only)</b> , that have been successfully and substantially completed and that are similar to the proposed works. The similarity shall be based on the physical size, complexity, methods/technology or other characteristics as described in <b>the Scope of Works</b>	Must meet requirement	Refer to standard form section 7
4.2(b)		b) For the above or other contracts executed during the period stipulated in 4.2(a) above, a minimum construction experience in at least one (1) of: <ul style="list-style-type: none"> <li>▪ Routine maintenance</li> <li>▪ Spot improvement &amp; rehabilitation works.</li> </ul>	Must meet requirements	Refer to standard form section 7
4.3	<b>Work Methodology</b>	Submission of a brief work methodology	Should demonstrate understanding of the scope of works and other general requirements	Refer to standard form section 7
<b>5. Equipment Holding</b>				
5.1	<b>Minimum number of Equipment</b>	The bidder must indicate the minimum the core plant and equipment considered by the company to be necessary for undertaking the project together with proof of ownership or leasing of at least two (2) different core plant/equipment necessary for undertaking the project to completion within the completion time	Must meet the requirement	Refer to standard form section 7

Qualification Criteria			Compliance Requirements	Documentation
No.	Subject	Requirement	Single Entity	Submission Requirements
<b>6. Current Commitment</b>				
6.1	<b>On-going contracts</b>	The total value of current works on the on-going contracts must not exceed <b>Kshs.10,000,000</b> [Kenya Shillings Ten Million]	Must meet requirements	Refer to standard form section 7
<b>7. Site Staff</b>				
1	Site Agent	The site staff shall possess minimum levels set below; Qualification = xxxxxx General Experience = xx years Specific Experience = xx years	Not Required	Not Applicable
2	Dep. Site Agent/ Site Engineer	Qualification = xxxxxx General Experience = xx years Specific Experience = xx years	Not Required	Not Applicable
3	Senior Foreman	Qualification = xxxxxx General Experience = xx years Specific Experience = xx years	Not Required	Not Applicable
4	Site Surveyor	Qualification = xxxxxx General Experience = xx years Specific Experience = xx years	Not Required	Not Applicable
5	Foremen (5 No.)	Qualification = xxxxxx General Experience = xx years Specific Experience =xx years	Not Required	Not Applicable

## **SECTION IV: CONDITIONS OF CONTRACT**

### **PART 1: GENERAL CONDITIONS OF CONTRACT**

The General Conditions of Contract are the FIDIC Short Form of Contract, First Edition, 1999, published by the International Federation of Consulting Engineers (FIDIC).

The General Conditions of Contract are linked with the Conditions of Particular Application, referred to as Part II, by the consecutive numbering of the Clauses, so that Part I and II together comprise the Conditions governing the rights and obligations of the Parties. In case of any inconsistency between the Conditions contained in Part I and those in Part II, the Conditions contained in Part II shall prevail.

The Tenderer is deemed to have read and fully complied with the General Conditions of Contract.



---

**PART II: CONDITIONS OF PARTICULAR APPLICATION**

The Conditions of Particular Application amplify the FIDIC Short Form of Contract so as to be, together, applicable to the Contract.

<b>CONTENTS</b>	<b>PAGE</b>
<b>GENERAL PROVISIONS.....</b>	<b>18</b>
1.1    DEFINITIONS.....	18
1.2    INTERPRETATION.....	18
<b>4    THE CONTRACTOR .....</b>	<b>20</b>
4.1.    GENERAL OBLIGATIONS.....	20
<b>4.1.1. R2000 Strategy .....</b>	<b>20</b>
<b>4.1.2 Approval of Equipment.....</b>	<b>20</b>
<b>4.1.3 Recruitment of Labour .....</b>	<b>20</b>
<b>4.1.4. Employment of Young Persons and Children .....</b>	<b>20</b>
<b>4.1.5. Conditions of Employment of Labour .....</b>	<b>21</b>
<b>4.1.6. Reporting Requirements.....</b>	<b>21</b>
<b>4.1.7. Non-payment of Wages by Contractor.....</b>	<b>21</b>
<b>4.1.8. Contract with Employees.....</b>	<b>22</b>
<b>4.1.9. Water for the Works .....</b>	<b>23</b>
<b>4.1.10. Environmental and Social Standards .....</b>	<b>23</b>
4.2.    PERFORMANCE SECURITY .....	23
<b>10.    VARIATIONS AND CLAIMS .....</b>	<b>24</b>
10.2    PERMITTED VARIATIONS.....	24
<b>11    CONTRACT PRICE AND PAYMENT .....</b>	<b>24</b>
11.1.    VALUATION OF THE WORKS.....	24
11.1.1.    Price Adjustment.....	24
11.1.2.    Exclusion of Price Adjustment for Late Completion of Works.....	25
11.1.3.    Dayworks .....	26
11.2.    INTERIM PAYMENTS .....	26
11.2.1.    Advance Payment .....	26
11.2.2.    Deductions for Re-payment of Advance Payment.....	26
11.2.3.    The Minimum Amount of Interim Payment. ....	26
<b>16.    FRAUD AND CORRUPTION.....</b>	<b>27</b>

## GENERAL PROVISIONS

### 1.1 Definitions

Add new Paragraph to sub-clause 1.1.8

1.1.8 (a) “**Week**” means a period of seven (7) consecutive days

1.1.8 (b) “**Month**” means calendar month

Add new paragraph to sub-clause 1.1.20 to 1.1.25

1.1.20 “**Appendix**” as referred to in the Conditions of Contract means Appendix to Form of Agreement.

1.1.21 “**Labour-Based Methods**” means work methods whereby activities are carried out using labour where technically and economically viable and appropriate equipment is only used when labour alone will not achieve the required standards.

1.1.22 “**Task**” means the amount of work to be done by one individual worker or a gang in order to earn one day’s wage.

1.1.23 “**Young Person**” means an individual male or female, who has attained the age of 16 years but has not attained the age of 18 years.

1.1.24 “**R2000 Strategy**” means an initiative by the Government of Kenya to improve the maintenance of the country’s Road Network by giving priority to maintenance through network approach, using appropriate technology, labour-based methods, local resources and increased usage of small-scale entrepreneurs.

### 1.2 Interpretation

Add sub-clause 1.2.1 as follows

1.2.1 Words having the same meaning

In the Contract Documents the Employer’s Representative is generally designated as the Engineer.

### 3. EMPLOYER'S REPRESENTATIVES

#### 3.1. Employer's Representative

The Director (Road Asset Management), Kenya Rural Roads Authority is the Employer's Representative.

#### 3.2. The Engineer

The Director (Road Asset Management), Kenya Rural Roads Authority the Employer's Representative has delegated to the Deputy Director Kenya Rural Roads Authority, Upper Western Region as the Engineer

#### 3.3 Engineer's Duties and Authority

- i. Give site possession to Contractors.
- ii. Give approval of the Contractor's Programme of works and site superintendent.
- iii. Issue site instructions and additional or modified drawings which may be necessary for the execution of the works and the remedy of any defects, all in accordance with the Contract.
- iv. Supervise the execution of the works and in particular ensuring the dimensions and quality of works conforms to specification.
- v. Review the Contractor's progress regularly and give notices whenever the contractor is performing poorly or is behind the approved programme of works.
- vi. Receive Contractors payment certificates, evaluate, approve and certify for payment.
- vii. Organize monthly progress review meetings and taking over meetings
- viii. Any other duties attributable to the Engineer as specified in or necessarily to be implied from the Contract.
- ix. The Engineer may delegate some of his duties and authority to Engineer's representative and will inform the Contractor accordingly in writing.

The Engineer shall obtain specific approval of the Employer before taking any of the following actions:

- 1) Consenting to the sub-contracting of any part of the works under **General Conditions of Contract Clause 4.3**
- 2) Issuing a variation or certifying additional cost determined under **Clause 10** except in an emergency situation as reasonably determined by the Engineer.
- 3) Determining an extension of time under **Clause 7.3**

## **4 THE CONTRACTOR**

### **4.1. General Obligations**

Add. In particular the following obligations shall apply

Add the following new sub-Clauses:

#### **4.1.1. R2000 Strategy**

The Works shall generally be carried out using the R2000 Strategy and work approach, with its predominant emphasis on the use of labour-based construction methods where they are technically and economically viable. Intermediate equipment, as agreed by the Engineer may be used in other appropriate circumstances.

#### **4.1.2 Approval of Equipment**

The Contractor shall submit for the Engineer's approval within seven days prior to the commencement date a list of equipment, which is intended for use on site. He shall notify the Engineer prior to bringing in equipment and shall further obtain the Engineer's approval prior to removing any equipment from site.

#### **4.1.3 Recruitment of Labour**

4.1.3.1 The Contractor shall ensure that there is a sufficient and suitable deployment of labour at all times throughout the Contract.

4.1.3.2 All general workers employed by the Contractor shall, to the extent possible, be recruited from the surrounding population. Exceptions may be made if sufficient local labour cannot be recruited and only with the approval of the Engineer. There shall be no discrimination in recruitment based on tribe, religion, political affiliation, age, disability or gender, and the recruitment system shall be fair and transparent.

4.1.3.3 The Contractor shall take particular note of the Government policy regarding the employment of women and youth in the recruitment process and shall take all possible steps to attain the targets of 30% of the labour force for each group.

#### **4.1.4. Employment of Young Persons and Children**

The Contractor shall comply with the relevant Employment Act concerning the Employment of Young Persons and Children.

#### **4.1.5. Conditions of Employment of Labour**

The Contractor shall observe and fulfil the following conditions in respect of all persons employed by him in the execution of the Contract: -

- a) Where possible, labour shall be employed on a daily task basis. The size of the daily task shall be that which can reasonably be expected of a worker during a normal working day (8 hours), and all task rates shall be approved by the Engineer.
- b) The Contractor shall pay wage rates and observe hours and conditions of employment of labour as established by Kenyan Labour Laws and by agreement between Employers or other recognized authorities and trades unions for similar trades or industries in the District where the Contract Works are to be carried out.
- c) The Contractor shall recognize the freedom of employees to be members of trades unions. The Contractor's attention is drawn to the requirements of the Trade Unions Act (CAP 233), which states that if at least 25% of the employees are members of a particular Trade Union Organisation, then the Contractor is legally bound to recognise and negotiate with the Organisation.

#### **4.1.6. Reporting Requirements**

The Contractor shall, when required by the Engineer, submit labour returns in such form and detail and at prescribed intervals showing the staff and the number of the several classes of labour employed by the Contractor.

#### **4.1.7. Non-payment of Wages by Contractor**

- a. The Employer may demand from the Contractor reasonable proof of payment of wages to the employees.
- b. The Employer may, upon the Contractor defaulting in payment, pay the money due, out of any funds due or which may become due to the Contractor under the Contract.
- c. In such an event, the Contractor shall co-operate with the Employer in processing the payment of the correct amounts of money due to the labour force by submitting the relevant muster rolls, workday reports and pay-sheets, and the Contractor shall be represented at the time payments are made.
- d. Direct payment to workers by the Employer shall attract a penalty as stated in the Appendix to cover expenses incurred in the administration of such labour payments.

#### **4.1.8. Contract with Employees**

(i) Working days

The Contractor shall recognize gazetted non-working days and allow in the Works Programme for those days on which labour is not expected to work.

(ii) Provision of Hand Tools

The Contractor shall provide his labour force with a sufficient number of hand tools of good quality and shall make the necessary provisions to maintain the tools in a good and safe working condition. The Engineer may instruct the Contractor to replace worn out, faulty or unsafe hand tools.

(iii) Safety and Health

- (a) The Contractor shall be responsible for the safety of all workers. In collaboration with, and to the requirements of the local health authorities, the Contractor shall ensure that first aid equipment and medical stores are available on the Site at all times throughout the period of the Contract, and shall also designate a Health and Safety Officer from amongst the staff.
- (b) The Contractor shall be responsible for the provision of potable water for the workers at appropriate locations on the Site.
- (c) In the event of any outbreak of illness of an epidemic nature the Contractor shall comply with and carry out such regulations, orders and requirements as may be made by the Government or the local medical or sanitary authorities for the purpose of dealing with and overcoming the same.

(iv) Contractor to Preserve Peace

The Contractor shall take all reasonable measures to ensure that all personnel on site comply with the Statutes, Ordinances, Laws, Regulations and By-Laws in force in Kenya, and to prevent accidents or any riotous or unlawful behaviour by or amongst the employees on or in connection with the Works, and for the preservation of the peace.

#### **4.1.9. Water for the Works**

The Contractor shall supply all water for the Works.

#### **4.1.10. Environmental and Social Standards**

The Contractor shall take all reasonable measures to protect the environment on the Site and to avoid damage or nuisance to persons and property. The Contractor undertakes to:

- i. Comply and also ensure that its subcontractors, if any, comply with international environmental and labour standards consistent with applicable law and regulations in the country of implementation of the Project, including the fundamental conventions of the International Labour Organisation (ILO) and international environmental treaties;
- ii. Adopt environmental and social risk mitigations measures as defined in the environmental and social management plan, refer to specifications clause 25-50-002 or the notice of environmental and social impact issued by the Employer.

#### **4.1.11. HIV/AIDS**

The Contractor shall institute on-site HIV/AIDS awareness and prevention campaigns for the duration of the Contract. This shall include the siting of information posters, the issue of condoms and also informatory meetings on site for the employees. The meetings shall be arranged with the assistance of the local health authorities and AIDS Campaign personnel, and shall be during working hours without loss of pay.

#### **4.2. Performance Security**

Add the following at the end of this clause.

The Performance Security shall be valid until the date of issue of the Employer's notice under sub-Clause 8.2 (Taking Over Notice). The Employer shall return the Security to the Contractor within 14 days thereafter.

A Performance Security in the form an Insurance Bond shall only be allowed from an Insurance Company approved by the Public Procurement Regulatory Authority (PPRA) and in a Form also approved by the PPRA.

## **10. VARIATIONS AND CLAIMS**

Add the following sub-clauses:

### **10.2 Permitted Variations**

- (d) The Engineer shall not be permitted to issue Variations to a value greater than the Tender Sum without approval from the Procurement Entity. The limit of approved Variations shall be + 25% of the Contract Sum.

## **11. CONTRACT PRICE AND PAYMENT**

### **11.1. Valuation of the Works**

Add the following sub-clauses:

#### **11.1.1. Price Adjustment**

The Contract shall not normally be subject to Price Adjustment. However, in exceptional and clearly identifiable economic circumstances, the Employer may consider a request from the Contractor for Price Adjustment where taxes, duties and/or basic costs for labour and specified materials have significantly increased since the commencement of the Works, as set out below,

- (a) Local Labour

For the purpose of this Sub Clause:

- (i) “Local Labour” means skilled, semi-skilled workers of all trades engaged by the Contractor on the Site for the purpose of or in connection with the Contract or engaged full time by the Contractor off the site for the Purpose of or in connection with the Contract (by way of illustration but not limitation: workers engaged full time in any office, store, workshop or quarry).
- (ii) “Basic Rate” means the applicable basic minimum wage rate prevailing on the date 28 days prior to the latest date for submission of Tenders, by reason of any National or State Statute or Ordinance.



- (iii) “Current Rate” means the applicable basic minimum wage rate for Local Workers by reason of any National or State Statute or Ordinance, prevailing on any date subsequent to the date 28 days prior to the latest date set for submission of Tenders.

b) Specified Materials

For the purpose of this Sub-Clause

- (i) “Specified Materials” means the basic materials required on the Site for the execution and completion of Works, which shall include fuel and lubricants; cement; aggregates; steel reinforcement; timber and gravel.
- (ii) “Basic Prices” means the prices for the specified materials prevailing on the date 28 days prior to the latest date for submission of Tenders.

The Engineer shall compile a Schedule of Basic Prices, upon which any claim for Variation shall be based, prior to the award of the Contract. The Contractor shall be entitled to a copy of the Schedule upon request to the Engineer.

- (iii) “Current Prices” means the prices for the specified materials prevailing on any date subsequent to the date 28 days prior to the latest date set for the submission of the Tenders, by reason of any National or State Statute or Ordinance,

(c) Overheads and Profits Excluded

In determining the amount of any adjustment to the Contract Price pursuant to this Sub-Clause no account shall be taken of any overheads or profits.

(d) Adjustments

The net amount of difference between the basic price and the current price payable by the Contractor when the specified services are provided or materials are bought shall, as the case may be, be paid to the Contractor.

(e) Notice and Records

The Contractor shall keep such books, accounts, invoices, receipts, time sheets and other documents and records as are necessary to enable any adjustment under this Clause to be made and shall at the request of the Employer furnish these duly verified in such a manner as the Employer may require for examination and checking.

### 11.1.2. Exclusion of Price Adjustment for Late Completion of Works

In the event of the Contractor failing to complete the Works within the Time of Completion as defined under Clause 7, or extension of the Contract period granted, the provisions of Clause 11 shall cease to apply.

Any part of the Works executed after the expiry of the Time for Completion shall be valued at a price levels prevailing at the contractual date of Completion.

### 11.1.3. Dayworks

The Contractor shall not execute any work on a Dayworks basis except by written order of the Engineer

Unless otherwise adjusted, payments for Dayworks shall be subject to price adjustment in accordance with the provisions of Clause 11.1.1

## **11.2. Interim Payments**

Add the following sub-clauses:

### 11.2.1. Advance Payment

The Employer may make Advance Payment to the Contractor on application after signing the Contract, against a Bank Guarantee, or approved Insurance Bond, in the form set out in the Tender Documents

This Advance Payment shall be up to a maximum amount stated in the Appendix.

### 11.2.2. Deductions for Re-payment of Advance Payment

Reimbursements of Advance Payment shall be made according to the schedule as stated in the Appendix.

### 11.2.3. The Minimum Amount of Interim Payment.

The minimum amount of an Interim Payment shall be stated in the Appendix.

## **16. FRAUD AND CORRUPTION**

16.1 If the Employer determines that the Contractor has engaged in corrupt, fraudulent, collusive, coercive or obstructive practices, in competing for or in executing the Contract, then the Employer may, after giving 14 days' notice to the Contractor, terminate the Contractor's employment under the Contract and expel him from the Site, and the provisions of Clause 56 shall apply as if such expulsion had been made under Sub-Clause 56.5 [Termination by Employer].

16.2 Should any employee of the Contractor be determined to have engaged in corrupt, fraudulent, collusive, coercive, or obstructive practice during the execution of the Works, then that employee shall be removed in accordance with Clause 9.

16.3 For the purposes of this Sub-Clause:

- (i) "corrupt practice" is the offering, giving, receiving or soliciting, directly or indirectly, of anything of value to influence improperly the actions of another party;
- (ii) "fraudulent practice" is any act or omission, including a misrepresentation, that knowingly or recklessly misleads, or attempts to mislead, a party to obtain a financial or other benefit or to avoid an obligation;
- (iii) "collusive practice" is an arrangement between two or more parties designed to achieve an improper purpose, including to influence improperly the actions of another party;
- (iv) "Coercive practice" is impairing or harming, or threatening to impair or harm, directly or indirectly, any party or the property of the party to influence improperly the actions of a party.

16.4 The Contractor declares that:

- a) They did not engage in any action to influence the Project implementation process to the detriment of the Employer, in particular no collusive practice took place nor will take place, and
- b) The bidding proceedings, contract award, and execution have not and will not be subject to any corrupt practice as defined in the United Nations Convention to combat corruption dated 31 October 2003.

## SECTION V: APPENDIX TO FORM OF AGREEMENT

This Appendix to Form of Agreement forms part of the Agreement.

Item	Data
Time for Completion	Six (6) Months
Priority of Documents	The documents forming the Contract shall be interpreted in the following order of priority: <ol style="list-style-type: none"> <li>i. the Contract Agreement and Appendix to form of agreement</li> <li>ii. the Letter of Acceptance</li> <li>iii. the Form of Tender</li> <li>iv. the Conditions of Contract, Part II - Conditions of Particular Application</li> <li>v. the Conditions of Contract, Part I - General Conditions of Contract (FIDIC Short Form 1999)</li> <li>vi. the Specifications</li> <li>vii. the Drawings,</li> <li>viii. the Priced Bill of Quantities</li> </ol>
Law of Contract	Laws of the Republic of Kenya
Language	English
Provision of Site	On Commencement Date
Name and Address of Employer	Director General, Kenya Rural Roads Authority, P.O. Box 48151-00100, <b>Nairobi.</b>
Employer's Representative	Director(Road Asset Management), Kenya Rural Roads Authority P.O. Box 48151-00100
Name and Address of the Engineer	Regional Director, Kenya Rural Roads Authority, Upper Western Region, P. O. Box 1473-50200, <b>Bungoma.</b>
Name and Address of Engineer's Representative	Constituency Roads Officer Kimilili <b>Upper Western Region</b>
Penalty to the Contractor for Employer paying workers on his behalf	10% of the amount paid to the workers.
Performance Security	Not Required

<b>Item</b>	<b>Data</b>
Amount	Not Applicable
Form	Not Applicable
Requirements of Contractors Design	Not Applicable
Programme	
⇒ Time of Submission	Within 14 days of Commencement Date
⇒ Form of Programme	Bar Chart
⇒ Interval Updates	As requested by the Principle Engineer
Liquidated Damages Amount payable due to failure to complete	0.01% of Contract Price per Day to a limit of 1% of Contract Price.
Defects Liability	Not Applicable
Period of notifying defects	Not Applicable
Percentage of Retention	Not Applicable
Maximum Amount of Advance Payment	Not Applicable
Form of Guarantee for Advance Payment	Not Applicable
Valuation of Works	Re-measurements with Bills of Quantities
Repayment Schedule for Advance Payment	Not Applicable
Minimum Amount of Interim Payment	Kshs. 2,000,000 (Kenya Shillings Two Million)
Currency of Payment	Kenya Shilling
Rate of Interest	Simple Interest at a rate of 2% above mean Base Lending Rate as issued by the Central Bank of Kenya.
Insurance	Not required
Insurance	Amount of Cover
⇒ The Works, materials plants & fees- Contractor's All risks	Not Applicable.
⇒ Third party injury to persons and damage to property	Not Applicable
⇒ Workers compensation (WIBA- (Workers Injury Benefits policy)	Not Applicable

Item	Data
Arbitration ⇒ Rules ⇒ Appointing Authority ⇒ Place of Arbitration	CAP 49 of the Laws of Kenya Chairman Chartered Institute of Arbitrators, Kenya Branch.  Kenya Rural Roads Authority, Headquarters, Nairobi

Bidder's Signature..... Date.....

## SECTION VI: STANDARD FORMS

<b>CONTENTS:</b>	<b>PAGE</b>
FORM OF TENDER .....	31
FORM OF AGREEMENT .....	31
QUALIFICATION INFORMATION .....	34
CONFIDENTIAL BUSINESS QUESTIONNAIRE .....	34
CERTIFICATE OF TENDERER'S VISIT TO SITE.....	37
FORM OF WRITTEN POWER-OF-ATTORNEY .....	37
SCHEDULE OF THE PROPOSED APPROPRIATE EQUIPMENT.....	38
SCHEDULE OF COMPLETED CIVIL WORKS CARRIED OUT IN THE PREVIOUS YEARS .....	39
SCHEDULE OF ONGOING PROJECTS.....	40
OTHER SUPPLEMENTARY INFORMATION .....	41
ADJUDICATOR'S AGREEMENT .....	42
FRAUD & CORRUPTION .....	44
ENVIRONMENTAL AND SOCIAL COMMITMENT .....	45
PUBLIC PROCUREMENT ADMINISTRATIVE REVIEW BOARD .....	46
DECLARATION FORM.....	47

# FORM OF TENDER

To: Regional Director,  
Kenya Rural Roads Authority,  
Upper Western Region,  
Bungoma Office,  
P.O Box 1473-50200,  
BUNGOMA.

Date: .....

## Routine Maintenance and Spot Improvement of C42 Rashid-Chebukwabi

Dear Sir,

1. In accordance with the Conditions of Contract, Specifications, Drawings and Bills of Quantities for the execution of the above Works, We, the undersigned offer to construct, install and complete such Works and remedy any defects therein for the sum of Kshs. \_\_\_\_\_ [Amount in figures]  
KenyaShillings \_\_\_\_\_  
\_\_\_\_\_ [Amount in words]
2. We undertake, if our Tender is accepted, to commence the Works on the commencement date and to complete the whole of the Works comprised in the Contract within the time stated in the Appendix.
3. We agree to abide by this Tender for **120 Days** from the date tender opening, and it shall remain binding upon us and may be accepted at any time before that date.
4. Unless and until a formal Agreement is prepared and executed this Tender together with your written acceptance thereof, shall constitute a binding Contract between us.
5. We understand that you are not bound to accept the lowest or any Tender you may receive.

Dated this \_\_\_\_\_ day of \_\_\_\_\_ 20\_\_\_\_\_

Signature \_\_\_\_\_ in the capacity of \_\_\_\_\_

duly authorized to sign Tenders for and on behalf of

\_\_\_\_\_ [Name of Tenderer] of

\_\_\_\_\_ [Address of Tenderer]

Witness: Name \_\_\_\_\_

Address \_\_\_\_\_

Signature \_\_\_\_\_

Date \_\_\_\_\_



## FORM OF AGREEMENT

**THIS AGREEMENT** is made on the .....day of..... between the **Kenya Rural Roads Authority, of P.O. BOX 48151 - 00100, Nairobi, Kenya** hereinafter called the “**Employer**” of the one part and .....hereinafter called the “**Contractor**” of the other part.

**WHEREAS** the Employer is desirous that certain works should be executed, viz: **Routine Maintenance and Spot Improvement of C42Rashid-Chebukwabi** and has accepted a Bid by the Contractor to execute, complete and maintain such works **NOW THIS AGREEMENT WITNESSETH as follows:**

In this agreement words and expressions shall have the same meanings as are respectively assigned to them in the Conditions of Contract hereinafter referred to.

The following documents shall be deemed to form and be read and construed as part of this Agreement, viz.:

The said BID dated.....

- Conditions of Contract; Parts I and II
- The Standard and Special Specifications;
- Priced Bill of Quantities;
- Letter of Acceptance;
- Form of Tender
- Drawings;
- Appendix to the Form of Agreement
- Schedule Of Supplementary Information
- Other Documents/Materials/Conditions agreed and documented.

All aforesaid documents are hereinafter referred to as “**The Contract**”.

In consideration of the payment to be made by the **Employer** to the **Contractor**, the Contractor covenants with the Employer to execute and complete the Works in conformity with the provisions of the Contract.

The Employer hereby covenants to pay the Contractor in consideration of the execution, completion and maintenance of the Works at the Contract Price or such other sum as may become payable under the Contract at the times and in the manner prescribed by the Contract.

**IN WITNESS WHEREOF** the parties hereto have caused their respective common seals to be hereto affixed (or have hereunto set their respective hands and seals) on the day and year first above written.

**SIGNED AND DELIVERED**

By the said Employer:

Name .....

Signature...

(Regional Director, Kenya Rural Roads Authority-  
Upper Western Region)

(For and on behalf of the said Employer.)

In the presence of:

Name.....

Signature.....

(Senior Supply Chain Management Officer  
Kenya Rural Roads Authority-Upper Western Region)

By the said Contractor:

Name.....

Signature.....

Designation:.....  
(For and on behalf of the said Contractor)

In the presence of:

Name.....

Signature:.....

Designation:.....

Address:.....

# QUALIFICATION INFORMATION

## TENDER QUESTIONNAIRE

Please fill in block letters.

1. Full name of Tenderer;  
.....
2. Full address of Tenderer to which Tender correspondence is to be sent (unless an agent has been appointed below);  
.....
3. Telephone number (s) of Tenderer;  
.....
4. Facsimile of Tenderer;  
.....
5. Name of Tenderer's representative to be contacted on matters of the Tender during the Tender period;  
.....
6. Details of Tenderer's nominated agent (if any) to receive Tender notices (name, address, telephone, telefax);  
.....  
.....

\_\_\_\_\_  
Signature of Tenderer

Make copy and deliver to Regional Deputy Director Kenya Rural Roads Authority, Upper Western Region,

P.O Box 1473-50200 BUNGOMA. (The Tenderer shall leave one copy at the time of purchase of the Tender documents)

# CONFIDENTIAL BUSINESS QUESTIONNAIRE

You are requested to give the particulars indicated in Part 1 and either Part 2 (a) or 2 (b) whichever applies to your type of business.

You are advised that it is a serious offence to give false information on this Form.

## Part 1 – General

Business Name .....

Location of business premises; Country/Town.....

Plot No..... Street/Road .....

Postal Address..... Tel No.....

Nature of Business.....

Current Trade Licensee No..... Expiring date.....

Maximum value of business which you can handle at any time: Kshs .....

Name of your Bankers.....

Branch.....

## Part 2 (b) – Partnership

Give details of partners as follows:

Name in full	Nationality	Citizenship Details	Shares
1.....			
2.....			
3.....			

## Part 2(c) – Registered Company:

Private or public.....

State the nominal and issued capital of the Company-

Nominal Kshs.....

Issued Kshs.....

Give details of all directors as follows:

Name in full .	Nationality.	Citizenship Details*.	Shares.
1.....			
2.....			
3.....			

**Part 2(d) – Interest in the Firm:**

Is there any person / persons in Kenya Rural Roads Authority who  
has interest in this firm? Yes/No..... (Delete as necessary)

I certify that the information given above is correct.

.....  
(Title) (Signature) (Date)

\* Attach proof of citizenship

## CERTIFICATE OF TENDERER'S VISIT TO SITE

This is to certify that

[Name/s].....  
.....

Being the authorized representative/Agent of [Name of Tenderer]  
.....  
.....

Participated in the organized inspection visit of the site of the works for the (participated in the organised inspection visit of the site of the work for **Spot Improvement and Routine Maintenance of C42 Rashid-Chebukwabi km 01+400 - 02+800.**

held on ..... day of.....20.....

Name.....  
(Employer's Representative)

Signed.....

Designation.....

NOTE: This form is to be completed when the site visit is made

## **FORM OF WRITTEN POWER-OF-ATTORNEY**

The Tenderer consisting of a joint venture shall state here below the name and address of his representative who is authorized to receive on his behalf correspondence in connection with the Tender.

.....

(Name of Tenderer's Representative in block letters)

.....

(Address of Tenderer's Representative)

.....

(Signature of Tenderer's Representative)

## SCHEDULE OF THE PROPOSED APPROPRIATE EQUIPMENT

Mandatory minimum number of equipment required by the Employer for the execution of the project  
that the bidder must make available for the Contract

Item No.	Equipment Details	Minimum Number Required	No of Equipment Owned by the Bidder	No. of equipment to be hired
1	Pedestrian Roller – Man walk behind	1		
2	Double drum vibrating pedestrian roller(3Tons)	1		
3	Self-propelled single drum vibrating (10Tons)	1		
4	Mobile concrete mixers	1		
5	Excavator/loader	1		
6	Concrete vibrators	1		
7	Tippers payload 7 – 10 tonnes	2		
8	Flat bed lorries	1		
9	Water tankers (10,000 litres capacity)	1		

The Bidder must attach certified copies of log books or lease agreement of the following

I certify that the above information is correct.

.....  
(Title)

.....  
(Signature)

.....  
(Date)



**SCHEDULE OF COMPLETED CIVIL WORKS CARRIED  
OUT IN THE PREVIOUS YEARS**

DESCRIPTION OF WORKS AND CLIENT	TOTAL VALUE OF WORKS (KSHS)	CONTRACT PERIOD (YEARS)	YEAR COMPLETED

I certify that the above Civil Works were successfully carried out and completed by ourselves.

.....  
(Title)

.....  
(Signature)

.....  
(Date)

## SCHEDULE OF ONGOING PROJECTS

DESCRIPTION OF WORK AND CLIENT	CONTRACT PERIOD	DATE OF COMMEN- CEMENT	DATE OF COMPLETION	TOTAL VALUE OF WORKS (KSHS.)	% COMPLETED TODATE

I certify that the above Civil Works are being carried out by ourselves and that the above information is correct.

.....  
(Title)

.....  
(Signature)

.....  
(Date)

## OTHER SUPPLEMENTARY INFORMATION

1. Financial reports for the last three years, balance sheets, profit and loss statements, auditors' reports, etc. List them below and attach copies.

.....  
 .....  
 .....

2. Evidence of access to financial resources to meet the qualification requirements. Cash in hand, lines of credit etc. List below and attach copies of supporting documents

.....  
 .....  
 .....

3. Name, address, telephone, telex, fax numbers of the Tenderer's Bankers who may provide reference if contacted by the Employer.

.....  
 .....  
 .....

4. Information on current litigation in which the Tenderer is involved.

OTHER PARTY (IES)	CAUSE OF DISPUTE	AMOUNT INVOLVED (KSHS)

I certify that the above information is correct.

.....  
 (Title)

.....  
 (Signature)

.....  
 (Date)

**ADJUDICATOR’S AGREEMENT**

Identification of Project:

.....  
(The “Project”)

Name and address of the Employer:

.....  
(The “Employer”)

Name and address of the Contractor:

.....  
(The “Contractor”)

Name and address of the Adjudicator:

.....  
(The “Adjudicator”)

**Whereas** the Employer and the Contractor have entered into a Contract (“the Contract”) for the execution of the Project and wish to appoint the Adjudicator to act as adjudicator in accordance with the Rules for Adjudication [“the Rules”].

**The Employer, Contractor and Adjudicator agree as follows:**

- 1. The Rules and dispute provisions of the Contract shall form part of this Agreement.
- 2. The Adjudicator shall be paid:

A retainer fee of ..... per calendar month(where applicable)

A daily fee of .....

Expenses (including the cost of telephone calls, courier charges, faxes and telexes incurred in connection with his duties; all reasonable and necessary travel expenses, hotel accommodation and subsistence and other direct travel expenses).

Receipts will be required for all expenses.

3. The Adjudicator agrees to act as Adjudicator in accordance with the Rules and has disclosed to the Parties any previous or existing relationship with the Parties or others concerned with the Project.
4. This Agreement shall be governed by the laws of.....
5. The Language of this Agreement shall be .....

SIGNED BY .....

For and on behalf of the Employer in the presence of

Witness .....  
Name .....  
Address .....  
Date .....

SIGNED BY .....

For and on behalf of the Contractor in the presence of

Witness .....  
Name .....  
Address .....  
Date .....

SIGNED BY .....

For and on behalf of the Adjudicator in the presence of

Witness .....  
Name .....  
Address .....  
Date .....

## FRAUD AND CORRUPTION

1 If the Employer determines that the Contractor has engaged in corrupt, fraudulent, collusive, coercive or obstructive practices, in competing for or in executing the Contract, then the Employer may, after giving 14 days' notice to the Contractor, terminate the Contractor's employment under the Contract and expel him from the Site.

2 Should any employee of the Contractor be determined to have engaged in corrupt, fraudulent, collusive, coercive, or obstructive practice during the execution of the Works, then that employee shall be removed.

3 For the purposes of this Sub-Clause:

(v) "corrupt practice" is the offering, giving, receiving or soliciting, directly or indirectly, of anything of value to influence improperly the actions of another party;

(vi) "fraudulent practice" is any act or omission, including a misrepresentation, that knowingly or recklessly misleads, or attempts to mislead, a party to obtain a financial or other benefit or to avoid an obligation;

(vii) "collusive practice" is an arrangement between two or more parties designed to achieve an improper purpose, including to influence improperly the actions of another party;

(viii) "Coercive practice" is impairing or harming, or threatening to impair or harm, directly or indirectly, any party or the property of the party to influence improperly the actions of a party.

4 The Contractor declares that:

c) They did not engage in any action to influence the Project implementation process to the detriment of the Employer, in particular no collusive practice took place nor will take place, and

The bidding proceedings, contract award, and execution have not and will not be subject to any corrupt practice as defined in the United Nations Convention to combat corruption dated 31 October 2003.

Dated this \_\_\_\_\_ day of \_\_\_\_\_ 20\_\_\_\_\_

Signature \_\_\_\_\_ in the capacity of \_\_\_\_\_

duly authorized to sign Tenders for and on behalf of  
\_\_\_\_\_ [Name of Tenderer] of

\_\_\_\_\_ [Address of Tenderer]

\_\_\_\_\_ [Seal or Stamp of Tenderer]

## ENVIRONMENTAL AND SOCIAL COMMITMENT

I have taken due note of the importance to comply with environmental and social standards and regulations.

I, the undersigned, [.....] acting as the duly authorized representative of [.....],

With respect to the submission of a bid for **Spot Improvement and Routine Maintenance of C42 Rashid-Chebukwabi, km 01+400 to 2+800**, in accordance with the invitation to **Tender No. KeRRA/011/BGM/KML/10%/39/20/21-083**, I undertake to comply, and ensure that our subcontractors, if any, comply with international environmental and labour standards consistent with applicable law and regulations in the country of implementation of the Project, including the fundamental conventions of the International Labour Organisation (ILO) and international environmental treaties

In addition, I also undertake to adopt any environmental and social risk mitigation measures as defined in the environmental and social management plan or the notice of environmental and social impact issued by the Employer.

Dated this \_\_\_\_\_ day of \_\_\_\_\_ 20\_\_\_\_\_

Signature \_\_\_\_\_ in the capacity of \_\_\_\_\_

duly authorized to sign Tenders for and on behalf of  
\_\_\_\_\_ [Name of Tenderer] of

\_\_\_\_\_ [Address of Tenderer]

\_\_\_\_\_ [Seal or Stamp of Tenderer]

**FORM RB 1**

**REPUBLIC OF KENYA**  
**PUBLIC PROCUREMENT ADMINISTRATIVE REVIEW BOARD**

APPLICATION NO.....OF.....20.....

BETWEEN

.....APPLICANT

AND

.....RESPONDENT (Procuring Entity)

Request for review of the decision of the..... (Name of the Procuring Entity) of .....dated the...day of .....20.....in the matter of Tender No.....of .....20...

**REQUEST FOR REVIEW**

I/We.....,the above named Applicant(s), of address: Physical address.....Fax No.....Tel. No.....Email ....., hereby request the Public Procurement Administrative Review Board to review the whole/part of the above mentioned decision on the following grounds , namely:-

- 1.
- 2.
- etc.

By this memorandum, the Applicant requests the Board for an order/orders that: -

- 1.
- 2.
- etc.

SIGNED .....(Applicant)

Dated on.....day of ...../...20...

---

**FOR OFFICIAL USE ONLY**

Lodged with the Secretary Public Procurement Administrative Review Board on ..... day of .....20.....

SIGNED  
Board Secretary



## DECLARATION FORM

Date \_\_\_\_\_

To: Regional Director,  
Kenya Rural Roads Authority,  
Upper Western Region,  
Bungoma Office,  
P.O Box 1473-50200,  
BUNGOMA.

The tenderer i.e. (Name and address) \_\_\_\_\_

\_\_\_\_\_ declare the following:

- a) Has not been debarred from participating in public procurement.
  
- b) Has not been involved in and will not be involved in corrupt and fraudulent practices regarding public procurement.

\_\_\_\_\_  
Title

\_\_\_\_\_  
Signature

\_\_\_\_\_  
Date

(To be signed by authorized representative and officially stamped)

**SECTION VII: CONTRACTOR'S EVALUATION CHECKLIST**

### Supervision Check List (1/2)

Project Title:	
Contractor:	

	Date	Name	Signature
The Engineer's Representative (Project Engineer)			
Resident Engineer			

1. This check list is for Resident Engineer to check contractor's work execution process.
2. Fill in date of checking as (day/month), mark as indicated in Filling Example, and state remarks.
3. Put this check list in the Monthly Progress Report.

Item	Check Point	before	During execution										after	Remarks <small>Reason for unsatisfactory performance (Site diary No.) Corrective order by authority (Date) Excellent point to be specified</small>	
		Date	Date	Date	Date	Date	Date	Date	Date	Date	Date	Date	Date		
1	1-1	Works Execution Programme (including its revised version if any) is submitted before the date specified in contract document	<input type="checkbox"/>	<input type="checkbox"/>	<input type="checkbox"/>	<input type="checkbox"/>	<input type="checkbox"/>	<input type="checkbox"/>	<input type="checkbox"/>	<input type="checkbox"/>	<input type="checkbox"/>	<input type="checkbox"/>	<input type="checkbox"/>	<input type="checkbox"/>	
	1-2	Works Execution Programme properly reflects the given specifications and site conditions	<input type="checkbox"/>	<input type="checkbox"/>	<input type="checkbox"/>	<input type="checkbox"/>	<input type="checkbox"/>	<input type="checkbox"/>	<input type="checkbox"/>	<input type="checkbox"/>	<input type="checkbox"/>	<input type="checkbox"/>	<input type="checkbox"/>	<input type="checkbox"/>	
	1-3	Execution procedures are in accordance with Works Execution Programme	<input type="checkbox"/>	<input type="checkbox"/>	<input type="checkbox"/>	<input type="checkbox"/>	<input type="checkbox"/>	<input type="checkbox"/>	<input type="checkbox"/>	<input type="checkbox"/>	<input type="checkbox"/>	<input type="checkbox"/>	<input type="checkbox"/>	<input type="checkbox"/>	
2	2-1	All equipment used are properly mobilized in accordance with Works Execution Programme	<input type="checkbox"/>	<input type="checkbox"/>	<input type="checkbox"/>	<input type="checkbox"/>	<input type="checkbox"/>	<input type="checkbox"/>	<input type="checkbox"/>	<input type="checkbox"/>	<input type="checkbox"/>	<input type="checkbox"/>	<input type="checkbox"/>	<input type="checkbox"/>	
	2-2	All equipment used is well maintained during the execution of works	<input type="checkbox"/>	<input type="checkbox"/>	<input type="checkbox"/>	<input type="checkbox"/>	<input type="checkbox"/>	<input type="checkbox"/>	<input type="checkbox"/>	<input type="checkbox"/>	<input type="checkbox"/>	<input type="checkbox"/>	<input type="checkbox"/>	<input type="checkbox"/>	
3	3-1	Qualified technical staff of contractor are properly assigned as specified in Works Execution Programme	<input type="checkbox"/>	<input type="checkbox"/>	<input type="checkbox"/>	<input type="checkbox"/>	<input type="checkbox"/>	<input type="checkbox"/>	<input type="checkbox"/>	<input type="checkbox"/>	<input type="checkbox"/>	<input type="checkbox"/>	<input type="checkbox"/>	<input type="checkbox"/>	
	3-2	Contractor's in-house key staff understand work process and schedule properly	<input type="checkbox"/>	<input type="checkbox"/>	<input type="checkbox"/>	<input type="checkbox"/>	<input type="checkbox"/>	<input type="checkbox"/>	<input type="checkbox"/>	<input type="checkbox"/>	<input type="checkbox"/>	<input type="checkbox"/>	<input type="checkbox"/>	<input type="checkbox"/>	
	3-3	Contractor's in-house staff give technical guidance and direction to workers and operators properly and timely	<input type="checkbox"/>	<input type="checkbox"/>	<input type="checkbox"/>	<input type="checkbox"/>	<input type="checkbox"/>	<input type="checkbox"/>	<input type="checkbox"/>	<input type="checkbox"/>	<input type="checkbox"/>	<input type="checkbox"/>	<input type="checkbox"/>	<input type="checkbox"/>	
	3-4	Communications with authority in writing is properly and timely	<input type="checkbox"/>	<input type="checkbox"/>	<input type="checkbox"/>	<input type="checkbox"/>	<input type="checkbox"/>	<input type="checkbox"/>	<input type="checkbox"/>	<input type="checkbox"/>	<input type="checkbox"/>	<input type="checkbox"/>	<input type="checkbox"/>	<input type="checkbox"/>	
4	4-1	Workers and operators are deployed in accordance with Works Execution Programme	<input type="checkbox"/>	<input type="checkbox"/>	<input type="checkbox"/>	<input type="checkbox"/>	<input type="checkbox"/>	<input type="checkbox"/>	<input type="checkbox"/>	<input type="checkbox"/>	<input type="checkbox"/>	<input type="checkbox"/>	<input type="checkbox"/>	<input type="checkbox"/>	
	4-2	Wage payment is properly made on time	<input type="checkbox"/>	<input type="checkbox"/>	<input type="checkbox"/>	<input type="checkbox"/>	<input type="checkbox"/>	<input type="checkbox"/>	<input type="checkbox"/>	<input type="checkbox"/>	<input type="checkbox"/>	<input type="checkbox"/>	<input type="checkbox"/>	<input type="checkbox"/>	
5	5-1	Office and stockyard are prepared in accordance with Works Execution Programme	<input type="checkbox"/>	<input type="checkbox"/>	<input type="checkbox"/>	<input type="checkbox"/>	<input type="checkbox"/>	<input type="checkbox"/>	<input type="checkbox"/>	<input type="checkbox"/>	<input type="checkbox"/>	<input type="checkbox"/>	<input type="checkbox"/>	<input type="checkbox"/>	
	5-2	Site is well maintained during the work execution and cleared on completion	<input type="checkbox"/>	<input type="checkbox"/>	<input type="checkbox"/>	<input type="checkbox"/>	<input type="checkbox"/>	<input type="checkbox"/>	<input type="checkbox"/>	<input type="checkbox"/>	<input type="checkbox"/>	<input type="checkbox"/>	<input type="checkbox"/>	<input type="checkbox"/>	
	5-3	Material stored on site is properly managed during the work execution	<input type="checkbox"/>	<input type="checkbox"/>	<input type="checkbox"/>	<input type="checkbox"/>	<input type="checkbox"/>	<input type="checkbox"/>	<input type="checkbox"/>	<input type="checkbox"/>	<input type="checkbox"/>	<input type="checkbox"/>	<input type="checkbox"/>	<input type="checkbox"/>	
6	6-1	Material testing, structural examination, and measurements are properly and routinely conducted based on specifications and Works Execution Programme	<input type="checkbox"/>	<input type="checkbox"/>	<input type="checkbox"/>	<input type="checkbox"/>	<input type="checkbox"/>	<input type="checkbox"/>	<input type="checkbox"/>	<input type="checkbox"/>	<input type="checkbox"/>	<input type="checkbox"/>	<input type="checkbox"/>	<input type="checkbox"/>	

Filling Example : ✓ Check point is satisfactory    ■ Check point is unsatisfactory    N/A Not applicable

### Supervision Check List (2/2)

Project Title:	
Contractor:	

The Engineer's Representative (Project Engineer)	Signature
Resident Engineer	

1. This check list is for Resident Engineer to check contractor's work execution process.
2. Fill in date of checking as (day/month), mark as indicated in Filling Example, and state remarks.
3. Put this check list in the Monthly Progress Report.

Item	Check Point	before	During execution										after	Remarks	
		Date	Date	Date	Date	Date	Date	Date	Date	Date	Date	Date	Date		Date
		/	/	/	/	/	/	/	/	/	/	/	/		Reason for unsatisfactory performance (Site diary No.) Corrective order by authority (Date) Excellent point to be specified
6	Quality and quantity management	6-2	Results of material testing, structural examination and measurements are within the specifications.												
		6-3	Results of material testing, structural examination, and measurements are properly compiled as reports for confirmation												
7	Work scheduling	7-1	Understanding of critical path and its reflection on scheduling are proper												
		7-2	Actual proceedings are periodically compared to the planned schedule described in Works Execution Programme												
		7-3	Changes caused by site conditions are properly handled to keep Works on schedule												
		7-4	All works are completed within the contract term or within the extended term as allowed											<input type="checkbox"/>	
8	Work safety management	8-1	No accident occurs to workers, operators, or third-parties.												
		8-2	Safety of workers and operators is considered												
		8-3	Accident prevention efforts for third-parties are proper												
		8-4	Traffic and site safety devices are properly installed and managed												
		8-5	Temporary facilities (e.g. scaffolding) are constantly checked												
9	Environmental and social management	9-1	Environmental and social mitigation efforts (e.g. against noise, vibration, emission, and dust ) are conducted												
		9-2	Waste material from site is properly disposed												
		9-3	Damage to existing roads, works and services is avoided or are repaired when it occurs												
		9-4	Transportation by vehicles is properly done with no overloading, and neither material falling, leakage, nor spillage.												

Filling Example : ✓ Check point is satisfactory    ■ Check point is unsatisfactory    N/A Not applicable

## SECTION VIII: SPECIFICATIONS, DRAWINGS AND BILLS OF QUANTITIES

### I. SPECIFICATIONS

<b>CONTENTS:</b>	<b>PAGE</b>
<b>SECTION 01: PRELIMINARY AND GENERAL ITEMS.....</b>	<b>54</b>
01-40-001: Mobilisation and Establishment of the Site.....	54
01-40-002: Clearance on Completion.....	55
0140-004: Quality Control Tests.....	55
01-40-005: Publicity Sign Boards.....	55
01-40-006: Traffic Control.....	56
01-40-007: Drinking Water.....	56
<b>SECTION 02 SETTING OUT.....</b>	<b>57</b>
02-50-001 Setting Out Horizontal Alignment.....	57
<b>SECTION 04 SITE CLEARANCE.....</b>	<b>58</b>
04-50-002 Grass cutting.....	58
04-50-003 Bush Clearing (heavy).....	59
04-50-004 Bush Clearing (Light).....	60
04-50-005 Pruning Tree Branches .....	61
04-50-006 Trees and Stumps Removal.....	61
04-50-007 Trees and Stumps Removal (>450mm girth).....	62
04-50-009 Rock/Boulder Removal.....	62
04-50-010 Stripping and Grubbing.....	63
<b>SECTION 08 CULVERT AND DRAINAGE WORKS.....</b>	<b>64</b>
08-50-002: Ditch Cleaning-manual.....	64
08-60-001/005: Culvert cleaning - partially blocked.....	65
08-60-006/010: Culvert cleaning - fully blocked.....	66
08-60-016/035: Concrete Pipe Culverts.....	66
08-70-001: Headwall Repair - masonry .....	68
08-70-002: Headwall Repair - concrete.....	68
08-70-003: Minor Drainage Structures - masonry.....	69
08-70-004: Minor Drainage Structures - concrete.....	69
08-70-005: Scour Checks – concrete.....	70
08-70-006: Scour Checks – masonry.....	71
08-70-007: Scour Checks - wooden stakes.....	71
08-70-016: Stone Pitching.....	73
08-80-002: Gabion Installation.....	74
08-80-003: Rock fill to Gabions.....	74
08-80-004: Drift Desilting.....	75
08-80-005: Drift Repairs - Concrete.....	75
08-80-006: Drifts - Stone Pitching.....	76
08-80-007: Drifts - Concrete.....	76
08-80-008: At-level Scour Checks.....	76
08-80-009: Stone Chute Stabilisation.....	77
08-80-010: Stone Post Chute Stabilisation.....	77
08-80-011: Stone Check Dams.....	80
08-80-012: Stone and Post Check Dams.....	80
<b>SECTION 10 GRADING AND GRAVELLING.....</b>	<b>82</b>

Labour Based Rehabilitation and Spot improvement Works- Level 2 Drawing & Bills of quantities\_

10-50-002:	Carriageway Grading - heavy.....	82
10-50-004:	Carriageway Grading - light.....	82
10-80-004:	Removal of Overburden - labour.....	84
10-80-009:	Removal of Overburden - equipment.....	85
10-80-005:	Haulage - Overhaul.....	86
10-80-007	Excavation; Free hand; Spreading and Compaction of Gravel-Labour.....	87
10-80-008	Excavation; Free Haul, Spreading and Compaction of Gravel-Equipment.....	87
10-80-010	Restoration of Quarries and Borrow Pits.....	88

## **SECTION 01: PRELIMINARY AND GENERAL ITEMS**

### **Scope:**

This section comprises those items that are required at the Commencement and Completion of the Works or that are Provisional Items applicable for the duration of the Works.

### **Location of Project**

The project is located in Kimilili Constituency. It is approximately 1.4km in length starting at Daraja Mungu Pri. School (km 01+400) terminating at Daraja Mungu (R.kibisi)

i, (km 2+800).

### **Extent of Contract**

The major works to be executed under the contract comprise mainly but are not limited to;

- Preliminaries
- Site Clearance
- Culvert and Drainage Works
- Grading and Gravelling

The works involve routine maintenance and spot improvement.

Grading would cover the entire road section between km 0+000 and 5+300 while gravelling wearing course would be in spot sections.

### **01-40- 001 Mobilization and Establishment of the Site**

The Contractor shall provide all equipment, tools, materials, temporary offices, stores and housing required to carry out the Works.

The Contractor shall ensure that all possible means of protection are given to the labour force at all times. Such protection shall include provision of high visibility clothing or vests, goggles and masks for workers in potentially dangerous locations or dealing with potentially harmful materials. The Contractor shall also maintain first aid kits with a minimum of the following items:-

- Non Stick wound dressing
- Selection of plaster/band aids
- Crepe bandages
- Gauze and cotton wool
- Antiseptic solution (washing wounds)
- Antiseptic cream – Betadine, Burnol
- Pain killers Panadol, Disprin

- Anti-diarrhoea – Immodium, Diadis, Charcoal
- Anti-histamine – Piriton, Triludan
- Anti-nausea – Stemetil
- Eye ointment
- Oral re-hydration sachets
- Surgical gloves

Measurement and Payment:

No separate payment shall be made for this item. The Contractor shall include the costs in the rates for other measured items.

#### **01-40- 002 Clearance on Completion**

On Completion of the Works, all temporary housing, equipment, signs and tools shall be removed from the site, and the site left in good order to the satisfaction of the Engineer.

Measurement and Payment

The Lump Sum payment will be made upon approval by the Engineer that the Clearance has been satisfactorily carried out.

#### **01-40-004 Quality Control Tests**

The Engineer may instruct the Contractor during the progress of the Works to carry out quality control tests to check materials and standards of workmanship, against the Specifications.

Where such tests indicate defective standards the Engineer shall instruct the Contractor to rectify the defects to the Engineer's satisfaction and at the Contractor's expense.

Measurement and Payment

The Engineer shall include a Provisional Sum for this item to be expended only as and when the Contractor is instructed to carry out tests.

#### **01-40-005 Publicity Sign Boards**

The Contractor shall provide Sign Boards as specified on the Drawings or as directed by the Engineer. The Sign Boards shall be placed at the beginning and end of the road or road section covered by this Contract.

Sign Boards shall be maintained for the duration of the Works, and removed on completion.



#### Quality Control

The Engineer shall check that Sign Boards have been erected in accordance with Drawings and Specifications.

Measurement: Number

The unit of measurement shall be number of Sign Boards erected

#### Payment

The unit rate shall be the full compensation for labour, tools, materials and incidental costs required for carrying out the work.

#### **01-40- 006      Traffic Control**

The Contractor shall provide warning signs, fences, and barriers, detours, which shall be properly positioned in advance of the Works to ensure that traffic is well and safely accommodated for the duration of the Works.

Traffic signs and other traffic control facilities shall be kept in good condition and located in positions where they are visible to road users.

#### Quality Control

The Engineer shall check regularly that traffic control measures are satisfactory.  
Measurement and Payment

A Lump Sum shall be paid on a Monthly basis upon the approval of the Engineer that satisfactory control measures are in place.

#### **01-40- 007      Drinking Water**

The Contractor shall provide safe drinking water on site for workers at a reasonable distance from all work locations, for the duration of the Works.

#### Quality Control

The Engineer shall check regularly that adequate supplies of water are available throughout the Site.

#### Measurement and Payment

A Lump Sum shall be paid on a Monthly basis upon the approval of the Engineer that adequate supplies have been provided.

### **SECTION 02 :            SETTING OUT**

**Scope**

This section covers the activities required in the re-establishment of the horizontal alignment of the road include setting out the centre line, cross section widths, drains and structures.

**02-50-001: Setting Out the Horizontal Alignment**

The Contractor shall set out the centreline to follow the existing road alignment unless instructed otherwise by the Engineer.

The minimum standards as shown in Table 2.1 shall apply

Table 2.1 Alignment Standards

Standard	Flat and Rolling Terrain	Hilly Terrain
<i>Horizontal Curves</i>		
Desirable Minimum radius	100m	50m

The cross section details of the road shall be as shown on the Drawing or as directed by the Engineer.

**Work Method**

The Contractor shall use **Labour** methods to carry out this item.

**Quality Control**

- Centreline pegs shall be set at 10m intervals on straight sections and 5m on curves
- Chainage or reference pegs shall be set out and marked at 20m intervals and located at one metre outside the cleared width and on both sides of the road.
- Cross section widths shall be checked at 10m intervals and shall have maximum tolerances of +/- 25mm

**Measurement Unit: m**

The measurement shall be the linear metres of the road

**Payment**

The unit rate shall be the full compensation for labour, tools, materials and incidental costs required for carrying out the work.

**SECTION 04: SITE CLEARANCE**

**Scope**

This section covers the clearance of bushes, shrubs, grasses, trees, stumps, boulders,

stripping and grubbing of the topsoil, removal of anthills and other unsuitable materials for the specified widths of the road, quarry and borrow areas. The distinction between light and heavy bush shall be decided by the Engineer.

The minimum site clearing widths for each of the activities shall be as shown in Table 4.1

Table 4.1: Site Clearing Widths

<i>Road Category</i>	<i>Run ning Surf face</i>	<i>Stripp ing and Grub bing</i>	<i>Trees, Stump s, Boulde rs</i>	<i>Bush Clear ing</i>
A/B/C + Secondary Roads	6.0 m	10.6 m	10.6 m	14.0 m
D/E + Minor Roads	5.4 m	10.0 m	10.0 m	13.0 m
RAR Roads	4.5 m	7.9 m	8.0 m	11.0 m
Minor / RAR roads with insufficient widths or Temporary Sections	3.5 m	6.9 m	7.0 m	9.0 m

#### **04-50-002 Grass Cutting (Manual)**

Grass shall be defined as any form of plant growth including small shrubs having a girth of not more than 100mm measured at height of 200mm above ground level.

The grass shall be cut to height of not more than 50 mm above the ground. The width limits shall be as instructed by the Engineer. All cut grass shall be removed from the carriageway, side drains, mitre drains and inlets and outlet drains of structures/culverts and deposited in approved spoil dumps.

**Burning of the grass shall not be allowed and care shall be taken not to damage roadside fixtures such as signs and marker posts.**

This activity shall be carried out twice, each time before the rainy season or as shall be instructed by the Engineer.

#### **Work Method**

The Contractor shall use **Labour** to carry out this item of work.

**Quality Control**

The road width for grass cutting shall be measured at 50-m intervals and shall be free of grass after the operation.

**Measurement:**  $m^2$

The measurement shall be area of grass cut, based on the standard width and measured length of clearing.

**Payment**

The unit rate shall be full compensation, for labour, materials, tools, and incidental costs required to carry out the work.

**04-50- 003 Bush Clearing (Heavy)**

Where the Engineer designates an area as Heavy Bush ( based on the undergrowth density) the Contractor shall clear all vegetation including small trees, shrubs and undergrowth, and their root systems, and shall salvage any re-useable timber or other material by cutting into logs and stacking. Other cleared material shall be collected and disposed of off-site as directed by the Engineer.

**Work Method**

The Contractor shall use **Labour** methods for this item

**Quality Control**

The Engineer shall check the cleared widths at 50 metre intervals

**Measurement Unit:**  $m^2$

The measurement shall be the area cleared to the specified width over the length as instructed by the Engineer.

**Payment:**

The unit rate shall be the full compensation for all labour, tools and incidental costs required to complete the work.

**04-50- 004 Bush Clearing (Light)**

The Contractor shall clear all vegetation including small trees, and shrubs with their root systems. Grasses and any undergrowth shall be cut to a height of not more than

100mm. The cleared material shall be collected and disposed of away from the side drains and in a manner that causes no visibility obstruction to traffic.

**Work Method**

The Contractor shall use **Labour** methods for this item

**Quality Control**

The Engineer shall check the cleared widths at 50 metre intervals.

**Measurement Unit:** m<sup>2</sup>

The measurement shall be the area cleared to the specified width over the length as instructed by the Engineer.

**Payment:**

The unit rate shall be the full compensation for all labour, tools and incidental costs required to complete the work.

**04-50-005 Pruning Tree Branches**

Where the Contractor instructed by the Engineer shall trim tree branches to improve visibility. Cut material shall be collected and disposed of as directed by the Engineer and burning of waste material shall not be permitted.

**Work Method**

The Contractor shall use **Labour** for this item.

**Quality Control**

The Engineer shall check for visibility improvement.

**Measurement and Payment**

A Provisional Sum shall be allowed for this item, which shall be paid under Dayworks.

**04-50- 006 Trees and Stumps Removal (200-450mm girth)**

Trees and Stumps outside the construction width but within the road reserve having a trunk girth of between 200-450mm at a point 600mm above the ground shall only be removed on the instruction of the Engineer.

The Contractor shall excavate around any trees to be removed to a depth not less than

0.5 m before cutting the roots. Existing stumps shall be uprooted in the same manner. All holes left by the removal of trees and stumps shall be back-filled with approved material and compacted to existing ground level. Cut material and stumps shall be collected and disposed of as directed by the Engineer. Burning of waste material shall not be permitted.

### **Work Method**

The Contractor shall use **Labour** methods for this item.

### **Quality Control**

The Engineer shall approve the removal, backfilling and satisfactory disposal of all waste material.

**Measurement Unit:** No

The measurement shall be the number of trees and stumps removed.

### **Payment**

The unit rate shall be the full compensation for all labour, tools and incidental costs required to complete this item.

### **04-50-007                      Trees and Stump Removal (>450mm girth)**

All the requirements of item 04-003 shall apply for trees and stumps greater than 450mm girth. In addition any re-useable timber from trees removed shall be cut into logs not more than 1.5 metres long and stacked as directed by the Engineer.

### **Work Method**

The Contractor shall use **Labour** methods, with appropriate sawing tools and equipment for this item.

### **Quality Control**

The Engineer shall approve the removal, backfilling and satisfactory disposal of all waste material.

**Measurement Unit:** No

Measurement shall be the number of trees and stumps removed

### **Payment:**

The unit rate shall be the full compensation for all labour, tools, equipment and incidental costs required to complete this item.

**04 -50-009                      Rock/Boulder Removal**

The Contractor shall remove in a manner agreed by the Engineer, rocks and boulders greater than 1.5 m girth using labour and appropriate equipment as necessary. Boulders shall be disposed of outside the road area.

**Work Method**

The Contractor shall use **Labour** and appropriate equipment methods for this item.

**Quality Control**

The Engineer shall approve the removal and satisfactory disposal of the boulders.

**Measurement Unit:** Provisional Sum

A Provisional Sum shall be included for this item

**Payment:**

Payment shall be made on a Dayworks basis.

**04-50-010                      Stripping and Grubbing**

The Contractor shall remove, over the widths shown in Table 4.1, topsoil including anthills, loose boulders up to 1.5m girth and other unsuitable material and deposit the debris outside the cleared area as directed by the Engineer.

**Work Method**

The Contractor shall use **Labour** methods for this item

**Quality Control**

The Engineer shall approve the stripped and grubbed area and the satisfactory disposal of waste material.

**Measurement Unit**      m<sup>2</sup>

The measurement shall be the area cleared as directed by the Engineer

**Payment**

The unit rate shall be the full compensation for all labour, tools and incidental expenses required to complete this item.

**SECTION 08: CULVERT AND DRAINAGE WORKS**

Scope

This section covers all Works in connection with the installation of concrete pipe culverts; inlet and outlet structures; drifts and drainage protection Works; and the construction of Scour Checks

**08- 50-002: Ditch Cleaning (Manual)**

i. Partially silted

Partially silted drains are those that are less than half silted and require only cleaning.

All deposited material, debris, and vegetation shall be removed and the drain shaped to the original cross-section and left in a free-draining condition. Suitable material may be used to fill depressions and potholes on the carriageway. All debris and other unsuitable material removed from the side drains shall be disposed of well clear of the drainage system in approved spoil dumps where it will not cause any obstruction or be washed back.

The side drains, mitre drains and catch water drains shall be cleaned before the onset of the rains or as directed by the Engineer.

Work Method

The Contractor shall use **Labour** to carry out this item of work

Quality Control

- Appropriate drain templates shall be used to check and control the dimensions of the drains.
- The longitudinal profile of the drains shall be checked using boning rods, to ensure free flow.

Measurement Unit: m

The measurement shall be the length of drain desilted or cleaned to the specified cross-section.

Payment

The unit rate shall be full compensation, for labour, tools, and incidental costs required to carry out the work.

ii. Fully silted

Fully silted drains shall be those that are greater than half-silted and require re-



excavation  
or reshaping.

All deposited material, debris, and vegetation shall be removed and the drain shaped to the original cross-section and left in a free-draining condition. Suitable material may be used to fill depressions and potholes on the carriageway. All debris and other unsuitable material removed from the side drains shall be disposed of well clear of the drainage system in approved spoil dumps where it will not cause any obstruction or be washed back.

The side drains shall be desilted or re-excavated before the onset of the rains, or as directed by the Engineer.

*Work Method*

The Contractor shall use **Labour** to carry out this item of work

*Quality Control*

- Appropriate drain templates shall be used to check and control the dimensions of the drains.
- The longitudinal profile of the drains shall be checked using boning rods, to ensure free flow.

Measurement Unit:                      m

The measurement shall be the length of drain re-excavated or re-shaped to the specified cross-section.

Payment

The unit rate shall be full compensation for labour, tools, and any incidental costs required to carry out the work.

**08-60-001/005:                      Culvert Cleaning (partially blocked)**

08-60-001	300mm	dia
08-60-002	450mm	dia
08-60-003	600mm	dia
08-60-004	900mm	dia
08-60-005	1200 mm	dia

This activity involves the cleaning of culverts of specified sizes including pipe barrels, the outlet/inlet structures, and the outlet drains, keeping them free of all debris, weed, silt and any obstruction to ensure free passage of water at all times. The debris shall be deposited in approved spoil dumps as directed by the Engineer

Partially blocked culverts shall be those with less than half of the barrel blocked.

Correct widths and slopes of the outlet drains shall be maintained. The gradient of the outlet drain shall be not less than 2 %.

All broken culvert barrels discovered in the course carrying out this activity shall be reported to the Engineer.

This activity shall be carried out before the rains, or as directed by the Engineer.

#### Work Method

The Contractor shall use **Labour** to carry out this item of work

#### *Quality Control*

The culverts shall be checked as free of debris to the satisfaction of the Engineer.

Measurement Unit: **m**

The measurement shall be the length of culvert, including the outlet drain, cleaned

#### Payment

The unit rate shall be full compensation for labour, tools and incidental costs required to carry out the work.

#### **08- 60 - 006/7/8/9/10 : Culvert Cleaning (Fully blocked):**

08 - 60 - 006 300mm dia;  
08 - 60 - 007 450mm dia;  
08 - 60 - 008 600mm dia;  
08 - 60 - 009 900mm dia;  
08 - 60 - 010 1200mm dia

This activity involves the cleaning of culverts of specified sizes including pipe barrels, the outlet/inlet structures, and the outlet drains, keeping them free of all debris, weed, silt and any obstruction to ensure free passage of water at all times. The debris shall be deposited in approved spoil dumps as directed by the Engineer

Fully blocked culvert shall be those with greater than half of the barrel blocked.

Correct widths and slopes of the outlet drains shall be maintained. The gradient of the outlet drain shall be not less than 2 %.

All broken culvert barrels discovered in the course of carrying out this activity shall be reported to the Engineer.

This activity should be carried out before the onset of the rains, or as directed by the Engineer.

**Work Method**

The Contractor shall use **Labour** to carry out this item of work.

*Quality Control*

The culverts shall be checked as free from debris, to the satisfaction of the Engineer.

Measurement Unit: m

The measurement shall be the length of culvert, including the outlet drain cleaned.

**Payment**

The unit rate shall be full compensation for labour, tools and incidental costs required to carry out the work.

**08-60-016/035 Concrete Pipe Culverts**

08-60-016	300	mm	haunched	(Type II)
08-60-017	300	mm	unhaunched	(Type I)
08-60-018	450	mm	haunched	(Type II)
08-60-019	450	mm	unhaunched	(Type I)
08-60-020	600	mm	haunched	(Type II)
08-60-021	600	mm	unhaunched	(Type I)
08-60-022	900	mm	haunched	(Type II)
08-60-023	900	mm	unhaunched	(Type I)
08-60-024	1200	mm	haunched	(Type II)
08-60-025	1200	mm	unhaunched	(Type I)
08-60-026	300	mm	semi-surround	(Type III)
08-60-027	300	mm	surrounds	(Type IV)
08-60-028	450	mm	semi-surround	(Type III)
08-60-029	450	mm	surround	(Type IV)
08-60-030	600	mm	semi-surround	(Type III)
08-60-031	600	mm	surround	(Type IV)
08-60-032	900	mm	semi-surround	(Type III)
08-60-033	900	mm	surround	(Type IV)
08-60-034	1200	mm	semi-surround	(Type III)
08-60-035	1200	mm	surround	(Type IV)

The Contractor shall supply, lay and joint concrete pipes to form culverts, including the concrete bedding; haunching or surrounds; and backfilling, in accordance with the Drawings for the Type and diameter specified in the Contract or directed by the Engineer.

The pipes shall be of Class 20/20 concrete, at least 28 days cured, and manufactured on site or procured from a supplier approved by the Engineer. The pipes shall be laid on a bedding of Class 15/20 concrete of dimensions as shown on the Drawings and jointed with cement mortar 1:4.

The culvert gradient including the outlet shall be a minimum 2%.

The pipes shall be haunched or surrounded, according to the Type specified, with Class 15/20 concrete to the dimensions shown on the Drawings or as directed by the Engineer.

Backfilling shall be carried with approved material and compacted in layers not exceeding 150 mm loose depth and placed evenly on each side of the pipe. Ramps shall be shaped to achieve a minimum overfill of 75% of the pipe diameter, and shall be tapered back on the carriageway to provide a gradual approach, as directed by the Engineer.

If the Contractor wishes to construct culverts in-site, using inflatable or collapsible forms the Engineer's approval shall first be sought for the proposed working method.

On completion the inside of the culvert shall be smooth, without displaced joints or other obstructions and true to line and level.

#### Work Method

The Contractor shall use **Labour** and appropriate **Equipment** to carry out this item work

#### Quality Control

- Concrete quality shall be checked for cracks, honey combing, and other defects.
- Before the pipes are laid, the gradient of the concrete bedding shall be checked and shall not be less than 2%
- The joints shall be checked to see that they have been properly made.

Measurement Unit: m

The measurement shall be in linear metres of the installed Type and size of culvert specified, measured net according to the Drawings.

#### Payment

The unit rate shall be the full compensation for labour, tools, materials, equipment and any other incidentals that may be required in carrying out the work.

**08- 70- 001    Head Wall Repair - Masonry**

This activity involves the repairs to damaged head walls and wing walls built in masonry.

Where directed by the Engineer, the masonry walls shall be inspected and loose or missing stone re-secured or replaced. Damaged pointing shall be repaired with cement mortar 1:4 and finished flush with the stonework.

#### Work Method

The Contractor shall use **Labour** to carry out this item of work

#### *Quality Control*

- The stability of the walls and the pointing shall be to the satisfaction of the Engineer.

Measurement Unit: No

The measurement shall be the number of walls repaired as directed by the Engineer.

#### Payment

The unit rate shall be full compensation for labour, materials, tools, and incidental costs required to carry out the work.

### **08-70-002 Headwall Repair - Concrete**

The activity involves the repairs to damaged concrete headwalls and wing walls, and to inlet/outlet concrete aprons. Concrete walls shall be inspected and repair works carried out as instructed by the Engineer to include breaking out and replacement of damaged concrete with similar material, and the rendering of open texture areas with cement mortar 1:4. Broken wall sections shall be re-built in 20/20 (1:2:4) concrete within formwork erected on the correct lines and levels in accordance with the Standard Drawings. Areas of new concrete and mortar shall be protected from direct sunlight and kept moist for 3 days.

#### Quality Control

The work shall be carried out to the satisfaction of the Engineer.

Measurement Unit: No

The measurement shall be the number of walls/aprons repaired.

#### Payment

The unit shall be full compensation for labour, materials, tools, and incidental costs required to carry out the work.

### **Minor Drainage Structures - Masonry**

<b>08-70-003</b>	<b>Type I</b>
<b>08-70-016</b>	<b>Type 2</b>
<b>08-70-017</b>	<b>Type 3(a)</b>
<b>08-70-018</b>	<b>Type 3(b)</b>
<b>08-70-019</b>	<b>Type 4</b>

The Contractor shall construct inlet and outlet structures for culverts including headwalls, wing walls in stone masonry or concrete block, and aprons in concrete to the dimensions and levels shown on the Drawings or as directed by the Engineer. The walls shall be built on foundations of class 15/20 concrete and jointed with cement mortar 1:4. The aprons shall be in Class 20/20 concrete and after laying the surface shall be kept moist for 3 days.

#### *Work Method*

The Contractor shall use **Labour** to carry out this item.

#### Quality Control

- The dimensions of the structures shall have a tolerance of + / - 10mm
- The levels shall have a tolerance of + / - 10mm
- The mortar joints shall be finished flush with the face of the walls.

Measurement Unit:                      m<sup>3</sup>

The measurement shall be the volume of the structures constructed, in whichever material, measured net according to the Drawings.

#### Payment

The unit rate shall be the full compensation for labour, tools, materials and any other incidentals that may be required in carrying out the work.

### **Minor Drainage Structures – Concrete**

<b>08-70-004</b>	<b>Type I</b>
<b>08-70-021</b>	<b>Type 3(a)</b>
<b>08-70-022</b>	<b>Type 3(b)</b>
<b>08-70-023</b>	<b>Type 4</b>

The Contractor shall construct inlet and outlet structures for culverts in concrete to the dimensions and levels shown on the Drawings or as directed by the Engineer.

Concrete shall be Class 20/20 unless otherwise specified. The formwork for the walls shall be erected on the concrete foundations, to the correct dimensions, and shall be approved by the Engineer before concrete is poured. Concrete shall be poured in a single lift and the top surface shall be kept moist for 3 days. Formwork may be struck after 2 days or as directed by the Engineer.

The Contractor shall use a concrete vibrator or other means approved by the Engineer to ensure full compaction of the concrete.

#### *Work Method*

The Contractor shall use both **Labour** and appropriate **Equipment** to carry out this item.

#### Quality Control

- The dimensions of the structures shall have a maximum tolerance of + 20mm / - 10mm
- The workability and mix of concrete shall be checked using the slump test and shall have a slump limit as directed by the Engineer. The frequency of testing shall be determined by the Engineer
- The concrete shall be checked for cracks, honey combing and other defects at the time of striking the formwork.

Measurement Unit:                      m<sup>3</sup>

The measurement shall be the volume of concrete in the completed structure, measured net in accordance with the Drawings.

#### **Payment**

The unit rate shall be the full compensation for labour, tools, materials, formwork, equipment and other incidentals that may be required in carrying out the work.

**08-70- 005    Scour Checks (Concrete)**

**08-70-006    Scour Checks (Masonry)**

**08-70-007    Scour Checks (Wooden Stakes)**

The Contractor shall construct scour checks using either stones, stakes, or concrete as instructed by the Engineer.

Construction of concrete scour checks shall be in class 20/20 concrete, unless otherwise specified, and to the details shown in the Drawings.

Spacing for scour checks shall be as shown in Table 8.1, or as directed by the

Engineer.

Table 8.1 : Scour checks spacing

Gradient of Drain	Scour Check Spacing	Gradient of Drain	Scour Check Spacing
4% or less	not required	8%	7.5m
5%	20m	9%	6m
6%	15m	10%	5m
7%	10m	>10%	4m

*Work method*

The Contractor shall use **Labour** to carry out this item.

Quality Control

The spacing of the scour checks shall have a tolerance of  $+ / - 0.5m$   
 The sizes of the stakes and stones used shall be in accordance with the Drawings  
 The shape of the scour check shall be checked using the scour check template.

Measurement Unit: No.

The measurement shall be the **number** of scour checks constructed.

**Payment**

The unit rate shall be full compensation, for labour, tools, materials and incidental costs required for carrying out the work.

- 08 – 70 – 008: Scour Check Repair - masonry**
- 08 – 70 – 009: Scour Check Repair - wooden**
- 08 - 70 - 010: Scour Check Repair - concrete**

This activity involves the repair of Scour Checks using stones or wooden stakes or concrete. The construction details shall be shown in the Drawings or as instructed by the Engineer.



Scour checks shall be inspected and the repairs carried out as directed by the Engineer, which shall include replacement of missing or broken stonework and stakes; and the repair of damaged concrete, to the original lines, levels, and Specifications.

*Work Method*

The Contractor shall use **Labour** to carry out this item work.

Quality Control

The sizes of the stakes and stones used shall be as the original construction. The shape of the scour check shall be checked using the scour check template.

Measurement: No.

The unit rate of measurement shall be the number of scour checks repaired.

Payment

The unit rate shall be full compensation, for labour, tools, materials, and incidental costs required for carrying out the work.

**08- 70- 011 : Stone Pitching Repair**

This activity involves the repair of stone pitching on slopes, in inlet/outlet aprons and access drifts. The stone pitching shall be inspected and repairs carried out as directed by the Engineer, including the replacement and re-bedding of missing or loose stones; the repair of mortar jointing; and the cleaning out of weepholes, as required. All work shall be to the lines and levels of the original construction with new stonework and mortar being flush with the adjacent materials.

Work Method

The Contractor shall use **Labour** to carry out this work

*Quality Control*

The work shall be carried out to the satisfaction of the Engineer.

Measurement Unit: m<sup>2</sup>

The measurement shall be the net surface area of the repairs.

Payment

The unit rate shall be full compensation, for labour, tools, materials, and incidental

costs required to carry out the work.

### **08-70- 016 : Stone Pitching**

The Contractor shall lay stone pitching at locations shown on the Drawings or as directed by the Engineer, which shall include levelling the area to be covered with stone pitching, collecting stones, laying stones, applying mortar to the joints and constructing weep holes, if required.

The area to be covered with stone pitching shall be trimmed to the level and slope shown on the Drawings or as directed by the Engineer. The prepared surface shall be firm and well compacted, with hand rammers.

The stones shall have minimum dimensions of 150mm and maximum 300mm and shall be set on the flat side and securely bedded, with the largest dimensions at right angles to the flow of water, in an interlocking pattern so as to leave only a minimum of voids between the stones which shall be filled with suitably shaped and tightly wedged spalls. The top of the pitching shall be finished flush with the adjacent material.

The stones shall be placed in full contact with the surface and bedded into cement mortar 1:4 with a minimum thickness of 100 mm. The mortar shall be worked into the pitching so that the voids between the stones are filled to the full depth of the pitching. The mortar shall be finished flush with the surface of the stones.

Weep holes shall be provided to stone pitching on slopes as directed by the Engineer.

The surface of the stone pitching shall be protected from direct sunshine and kept moist for 2 days.

#### Work Method

The Contractor use **Labour** to carry out this item.

#### Quality Control

- The quality of pitching shall be checked for gaps and voids.
- The dimensions of the area of stone pitching shall have a tolerance of + / - 100mm

Measurement Unit:                      m<sup>2</sup>

The measurement shall be the total area of pitching calculated as the net area, measured on the slope.

#### Payment

The unit rate shall be full compensation, for labour, tools, materials, and incidental costs required for carrying out the work.

### **08-80- 002 : Gabions**

The Contractor shall provide and install Gabions as retaining walls and anti-erosion structures at locations shown on the Drawings or as directed by the Engineer.

Gabions shall include mattresses and boxes and for purposes of construction, measurement and payment, no distinction shall be made between them.

Gabions shall be ‘Maccaferri’ boxes or ‘Reno’ mattresses or equivalent approved by the Engineer.

The surfaces on which the Gabions are to be laid prior to being filled with rock shall be levelled to the depths and dimensions shown on the Drawings or as directed by the Engineer.

Gabion boxes shall be tied together with 3 mm galvanised binding wire securing all edges at 150mm intervals.

#### Work Method

The Contractor shall use **Labour** to carry out this item.

#### Quality Control

The placing and tying of the Gabions shall be approved by the Engineer before filling commences.

Measurement Unit: No

The measurement shall be the number of Gabion boxes installed.

#### **Payment**

The unit rate shall be the full compensation for labour, materials, and any incidental item costs necessary to carry out the work.

### **08-80-003 : Rockfill to Gabions**

The Contractor shall provide selected rock, crushed if necessary, and carry out the packing and compacting of the rock inside the Gabion boxes.

The boxes shall be filled in layers from the sides towards the middle in an interlocking stone matrix to prevent deformation and bulging. The interior and top layers of the boxes shall be hand packed with smaller stone to form a tightly compact structure and

rammed in place. Care shall be taken to ensure that each layer of boxes is filled evenly and to a level surface before the next course of boxes is placed.

Work method

The Contractor shall use **Labour** to carry out this activity.

Quality Control

The filling and compaction of the stones in the Gabion boxes shall be approved by the Engineer.

Measurement Unit    m<sup>3</sup>

Rockfill to Gabions shall be the volume of Gabions filled.

**Payment**

The unit rate shall be the full compensation for labour, tools, materials and incidental costs required for carrying out the work.

#### **08- 80- 004    Drift Maintenance – desilting**

This activity involves the removal of debris, silt and any vegetation from drifts and causeways. The debris shall be deposited away from the drift in approved spoil dumps.

This activity shall be carried before the rains, or as directed by the Engineer.

Work Method

The Contractor shall use **Labour** to carry out this item of work

*Quality Control*

The work shall be carried out to the satisfaction of the Engineer.

Measurement Unit:            m<sup>3</sup>

The measurement shall be the volume of debris or silt removed calculated as the product of length, width and measured depth of the affected section of drift.

Payment

The unit rate shall be full compensation for labour, tools, and incidental costs required to carry out the work.

**08-80-005 Drift Repairs – Concrete**

This activity involves the repair of concrete drifts, including the removal of loose or broken concrete, cutting back damaged areas to sound surfaces and repairing with concrete of similar Class to the original.

The drift shall be inspected and necessary repairs shall be instructed by the Engineer. Holes and voids shall be cleared of debris, loose material and dust, and shall be well watered before the new concrete is placed. The new concrete shall be firmly rammed against the existing surfaces and finished flush with the surrounding materials. The surface of the repair shall be protected from direct sunlight and kept moist for 3 days. Concrete shall be Class 20/20 unless otherwise directed by the Engineer.

**Quality Control**

The work shall be carried out to the satisfaction of the Engineer.

Measurement Unit: m<sup>3</sup>

The measurement shall be the volume of concrete used for the repair.

**Payment:**

The unit rate shall be the full compensation for labour, tools, materials and incidental costs required to carry out the work.

**08- 80-006 Drifts (Stone Pitching)**

**08-80-007 Drifts (Concrete)**

The Contractor shall construct Access drifts in grouted stone pitching and watercourse drifts in concrete at locations, and to the dimensions, shown on the Drawings or as directed by the Engineer. This shall include the provision of stone and the levelling of the areas to be covered.

The stone pitching for Access drifts shall comply with the requirement of 08–70-016 with the addition of masonry toes at each end of the drift as shown on the Drawings.

Concrete drifts shall be constructed in Class 20/20 concrete to the lines and dimensions shown on the Drawings or as directed by the Engineer.

The area to be covered shall be trimmed to the line and slope shown on the Drawings or as directed by the Engineer, and the prepared surface compacted with hand rammers or appropriate equipment. The concrete shall be poured in bays of half road width and of length 10-15 metres, between construction joints, with steel mesh reinforcement mats laid 50mm below the finished surface level. Contraction joints if

required shall correspond with the construction joints where directed by the Engineer expansion joints shall be installed at positions and to the details given by the Engineer.

The grouted stone pitching and the concrete shall be covered with wet sacking or other approved cover for not less than 4 days after laying and shall not be subject to loading until adequate strength has been developed as instructed by the Engineer.

#### Work Method

The Contractor shall use **Labour** and appropriate **Equipment** to carry out this item.

#### Quality Control

- i) Stone pitching quality shall be as for 08-70-016
- ii) Concrete shall be checked by slump test to the standard as directed by the Engineer.

Measurement Unit    m<sup>3</sup>

The measurement shall be the volume of stone pitching or concrete laid, measured net according to the Drawings.

#### Payment

The unit rate shall be full compensation for labour, tools, materials, equipment and incidental costs required for carrying out the work.

### **08-80-008      At-level Scour Checks**

The Contractor shall select and place flat stones of minimum dimensions 0.10-0.15m in gently sloping channels. The stones shall be placed in a manner to ensure minimum voids within the structure. A trench 0.2m deep by 0.2m wide shall be excavated in the invert of the channel and extended 0.2m into the slopes. Stones shall be laid up to the level of the invert with the middle section lower than the sides to form a spill way. The spacing of the checks shall be 1-4 metres, as directed by the Engineer.

#### Work Method

The Contractor shall use **Labour** to carry out this item.

#### Quality Control

The construction and spacing of the scour checks shall be checked by the Engineer.

Measurement Unit:    No

The measurement shall be the number of scour checks constructed.

#### Payment

The unit rate shall be full compensation for labour, tools, materials and incidental costs required to carry out the work.

**08-80-009/010            Gully-head Protection**

**08-80-009                Stone Chute Stabilisation**

**08-80-010                Stone and Post Chute Stabilisation**

The Contractor shall construct gully-head protection works as directed by the Engineer to the dimensions and details shown on the Drawings.

The dimensions of the stones shall not be less than 200mm and the volume not less than 0.01m<sup>3</sup> for the smaller stones and pebbles to be used as the transition layer between the stone structure and the ground. No rounded stones shall be used. Posts shall be durable hardwood minimum 900mm in length and 15mm diameter.

The gully head shall be excavated as shown on the Drawings to form a firm base for the stone layers. The initial layer shall be the small stones and gravel to a depth of 150mm after which the larger stone shall be carefully placed to form a compact matrix. Posts shall be driven a minimum of 600mm into the ground at a spacing as directed by the Engineer.

#### Work Method

The Contractor shall use **Labour** to carry out this item

#### Quality Control

The stone dimensions and construction shall be checked by the Engineer.

Measurement Unit:    No

The measurement shall be number of units constructed

#### Payment

The unit rate shall be full compensation for labour, tools, materials and incidental costs required to carry out the work.

**08-80-011/012            Check Dams**

**08-80-011                Stone Dams**

**08-80-012 Stone and Post Dams**

The Contractor shall construct check dams in erosion gullies to the dimensions and details shown on the Drawings and as directed by the Engineer.

The dimensions of the stones in the main structure shall not be less than 200mm and the volume not less than 0.01 m<sup>3</sup> for the stones and pebbles for the transition layer between the stone structure and the ground. No rounded stones shall be used.

Posts shall be durable treated hardwood of minimum diameter 0.10m, of minimum length 1.6m, driven at least 600mm into the ground. Stones shall be carefully hand-packed to provide a stable structure with a minimum of voids.

The spacing of the check dams shall be as shown in the table below:

<b>Check Dam Spacing</b>					
<b>Gradient</b>	<b>Height of dam spill way (m)</b>				
	<b>0.15</b>	<b>0.25</b>	<b>0.50</b>	<b>0.75</b>	<b>1.00</b>
5	15.0	25.0			
7	5.0	8.7	17.5	25	35
10	2.5	4.2	8.4	12.6	16.8
15	1.4	2.3	4.6	6.9	9.2
20	0.9	1.6	3.2	4.8	6.4
25		1.3	2.5	3.8	5.0
30		1.0	2.0	3.0	4.0
40			1.6	2.4	3.2
50			1.2	1.8	2.0

**Work Method**

The Contractor shall use **Labour** to carry out this item

**Quality Control**

The Engineer shall check the workmanship and spacing of the check dams.

Measurement Unit: No

The measurement shall be the number of check dams constructed

**Payment**

The unit rate shall be full compensation for labour, tools, materials and incidental costs required to carry out the work.



**SECTION 10: GRADING AND GRAVELLING**

**Scope:**

Grading covers the work of the reinstating of the road carriageway to the correct camber by removing the high points and filling gullies, corrugations, and wheel ruts to restore a smooth running surface. Graveling consists of the excavation, loading, hauling, dumping and spreading of gravel wearing course material on the formation of the road carriageway. Gravel shall include lateritic gravel, quartzitic gravel, calcareous gravel, decomposed rock, soft stone coral rag, clayey sand and crushed rock.

The material may be obtained from quarries, borrow pits or excavation in cuttings as directed by the Engineer. Gravel material shall conform to the requirement given in Table 10.1

Table 10.1: Requirement for Gravel Wearing Course

GRADING REQUIREMENTS		PLASTICITY INDEX REQUIREMENTS PI		
Sieve (mm)	% by Weight Passing	Zone	Min	Max
40	100	WET: Mean annual	5	20
28	95 - 100	DRY: Mean annual	10	30
20	85 - 100			
14	65 - 100			
10	55 - 100			
5	35 - 92			
2	23 - 77			
1	18 - 62			
0.425	14 - 50			
0.075	10 - 40			

BEARING STRENGTH		
Traffic VPD	CB	DCP Equiv mm/
>15	20	11
<15	15	14
CBR at 95 % MDD, Modified AASHTO and 4 days soaking		
Lower quality material (CBR 15) may be accepted if no better material can be found		

For “Quarry Waste” gravel stones of maximum dimension 80mm may be permitted

The Engineer shall approve quarries and the extent of their exploitation. The quarries shall be shown to the Contractor prior to commencement of the Works. The Contractor shall be responsible for the acquisition of the quarry rights and shall

conduct respective negotiations with landowners and affected communities.

Alternative sources of gravel material whose quality can be shown to be in compliance with the specification requirements may be used, with the approval of the Engineer and at no extra cost to the Employer. The Contractor is deemed to have included in his rates for the provision of the gravel material.

### **10-50-002 Carriageway Grading – Heavy Grading**

The Contractor shall scarify the existing carriageway surface, cutting high spots and moving materials to fill potholes, corrugations and wheel ruts and reshape the surface to the specified camber, using a Motor grader unless otherwise directed by the Engineer. All loose rocks, roots and grasses shall be removed and disposed of well clear of the drains.

Pegs 300 to 400mm long shall be placed at 20 m intervals to mark edge of the carriageway.

The material shall be bladed toward the Centre of the road starting from both edges until the specified camber is achieved. Suitable material from the side drains may be used as additional material. Any further material needed to achieve the correct camber shall be from an approved source. Compaction shall be carried out using appropriate equipment approved by the Engineer, from the carriageway edges to the centerline in overlapping passes.

No grading shall be carried out in dry conditions. Where additional moisture is required to achieve compaction it shall be added in an even manner without transverse or longitudinal flow.

#### Work Method

The Contractor shall use **Equipment** to carry out this item.

#### Quality Control

- The width of the carriageway shall be checked at every 50m intervals and have a tolerance of + 50mm or .20mm.
- The camber shall be checked with a camber board at 25m intervals and shall have a tolerance of +/- 1%

Measurement Unit:                      m<sup>2</sup>

The measurement shall be the area of carriageway graded, measured net according to the specified width and measured length graded.

#### Payment



The Contractor shall remove overburden from quarries and borrow pits, which includes loading, hauling and stockpiling at approved locations. The thickness of the overburden layer to be removed shall be determined from trial pits dug on a 30 metre grid within the quarry area.

The overburden shall be deposited neatly for re-use to reinstate the quarry on completion of the Works, as directed by the Engineer.

Work Method:

The Contractor shall use **Labour** and appropriate **Equipment** to carry out this item.

Quality Control

- The location and manner of stock piling of the overburden for the reinstatement of the quarry shall be to the approval of the Engineer.

Measurement Unit:  $m^3$

The measurement shall be the volume of overburden removed as calculated from the cleared area and the mean depth indicated from the trial pits.

Payment

The unit rate shall include full compensation for labour, tools materials and equipment, haulage, stockpiling and incidental costs required for carrying out the work.

#### **10-80- 005: Haulage (Overhaul beyond 1.5km)**

The Contractor shall load the excavated gravel, haul by appropriate equipment and off-load on the road as directed by the Engineer. Where the quantity delivered in any load falls short of the equipment capacity, off-loading shall only be permitted after the agreed spacing is adjusted accordingly.

No vehicle with a capacity of greater than 10 tonnes shall be permitted to off-load gravel directly on the prepared formation. Any greater loads shall be dumped in stockpiles off-road and transported to the formation areas by appropriate means.

Where loads supplied are found to contain material other than from the approved quarry and are of unacceptable quality, the Contractor shall remove them from site at the Contractor's expense.

Work Method:

The Contractor shall use both **Labour** and **Equipment** to carry out this Item.

Quality Control:

- No haulage equipment shall be used until its capacity has been ascertained by the Engineer
- The quality of gravel dumped on the road shall be according to the Specifications
- The quantity of material delivered in each load shall be checked before dumping is allowed
- The distance between the stacks shall be checked to ensure the required compacted thickness will be achieved.

Measurement Unit:                      m<sup>3</sup>km (Overhaul)

The Contractor shall allow in the rates for item 10-80-007 for a 'free' haul distance of 1.5km. The 'overhaul' shall be the distance, greater than 1.5km, to the centre point of the section where the gravel is being dumped and processed, measured along the shortest route as determined by the Engineer.

The measurement of overhaul shall be the product of the volume of the gravel hauled and the distance to the centre point as indicated above.

Payment

The unit rate shall include full compensation for labour, tools, equipment, and incidental costs necessary to carry out the work.

### **Excavation, Free haul, Spreading and Compaction of Gravel**

**10-80-007 - Labour**

**10-80-008 - Equipment**

#### **Excavation of Gravel - Labour - Equipment**

Gravel shall be excavated from quarries approved by the Engineer, and the Contractor shall inform the Engineer if the quality/availability of the gravel changes during the course of excavation. Excavation and loading shall normally be by labour unless, at the request of the Contractor, the Engineer allows the use of equipment.

Stones and boulders with one dimension greater than 80mm shall be removed from the excavated gravel and deposited outside the quarry at locations approved by the Engineer. Such stones and boulders may be reused in other parts of Works with the approval of the Engineer.

Work Method

The Contractor shall use **Labour** and/or **Equipment** to carry out this work, as directed by the Engineer.

Quality Control:

- Oversize stones and boulders shall not be loaded for haulage to the road.
- Areas containing deleterious material shall not be excavated.

**Free haul, spreading and Compaction of Gravel**

The Contractor shall spread and compact gravel material, in a manner to ensure a uniform thickness of the layer across the full width of the carriageway and shaped to the specified camber. Spreading also includes the removal of any oversized stones or boulders, which cannot be broken down to the required size, to spoil dumps. Gravel shall be spread within 24 hours of off-loading.

Compaction of the gravel material shall be carried out from the carriageway edges to the centerline by overlapping passes of the compaction equipment. The number of passes shall be as directed by the Engineer dependent upon the equipment used and the material being compacted. Unless otherwise instructed the moisture content of the material shall be within  $\pm 2\%$  of optimum

Where additional moisture is required water shall be applied in an even manner and the rate of application shall be such that no transverse or longitudinal flows occur.

The Engineer may instruct the Contractor to carry out density tests on the compacted material to ensure that an acceptable standard has been achieved.

Work Method:

The Contractor shall use **Labour** and/or appropriate **Equipment** to carry out this item.

Quality Control:

- The gravel surface width shall be checked at 100m intervals and shall have a tolerance of  $+ / - 50\text{mm}$
- Trial holes shall be dug as directed by the Engineer to check the gravel thickness and shall have a tolerance of  $+ 5\text{mm} / - 0\text{mm}$
- The camber shall be checked at 50m intervals and the maximum tolerance shall be  $+ / - 1\%$
- The longitudinal profile shall be checked after the compaction of each load to ensure a smooth surface with no corrugations or depressions

Measurement Unit:  $\text{m}^3$

The measurement shall be the volume of compacted gravel surfacing measured net according to the Drawings and shall include the excavation and the 1.5km 'free' haul distance

### Payment

The unit rate shall be the full compensation for labour, tools, equipment and incidental costs required for carrying out the work.

### **10-80-010            Restoration of Quarries and Borrow Pits**

The Contractor shall level the ground, return the topsoil from the stockpiles, and uniformly spread the material over the full excavation area.

Adequate drainage provisions shall be made to protect the excavation areas, and where necessary appropriate protection measures shall be taken to avoid erosion of the spread topsoil layer. Grass and trees shall be replanted as directed by the Engineer.

### Work Method

The Contractor shall use **Labour** and/or **Equipment** to carry out this item as agreed by the Engineer.

### Quality Control

The Engineer shall check that the required measures have been satisfactorily taken.

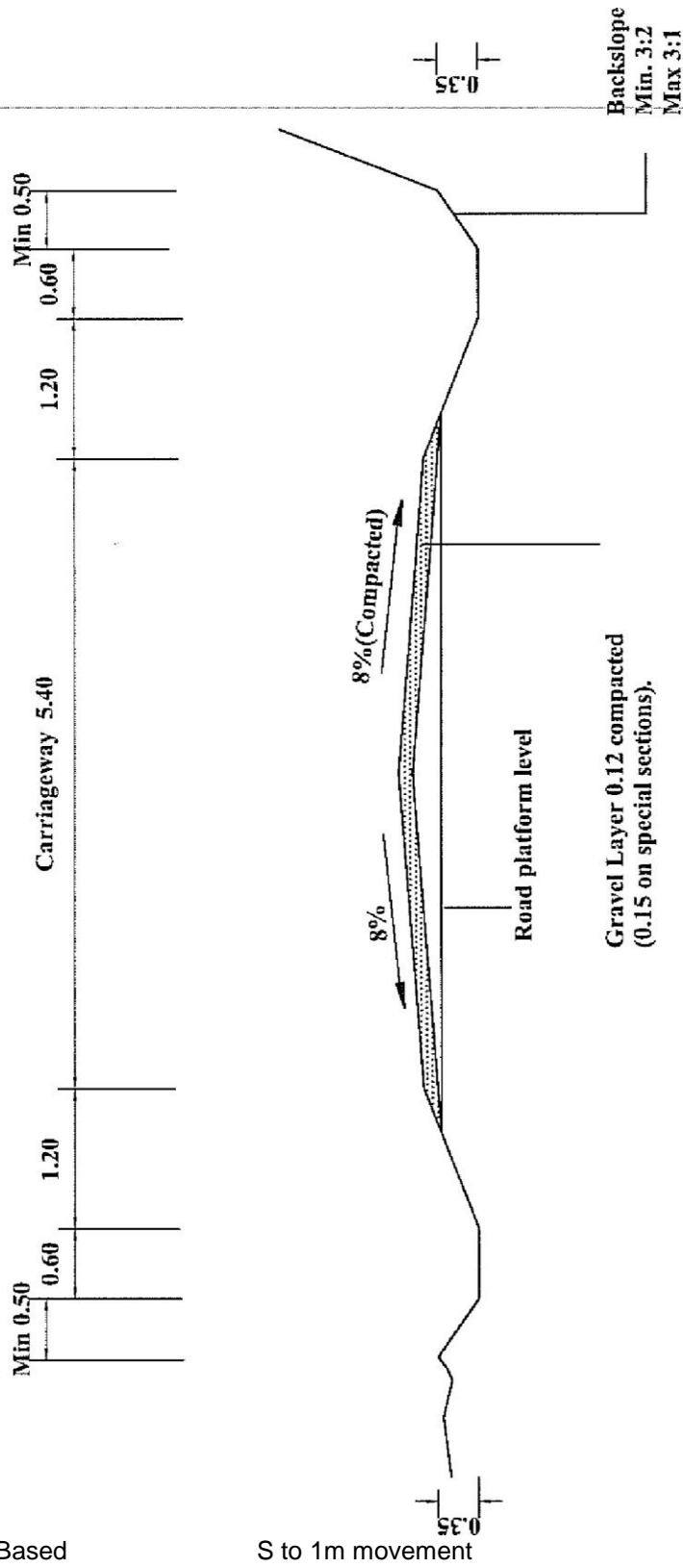
Measurement and Payment:            Provisional Sum

Payment shall be made on a Day works basis for the labour and equipment as directed by the Engineer

## **DRAWINGS**

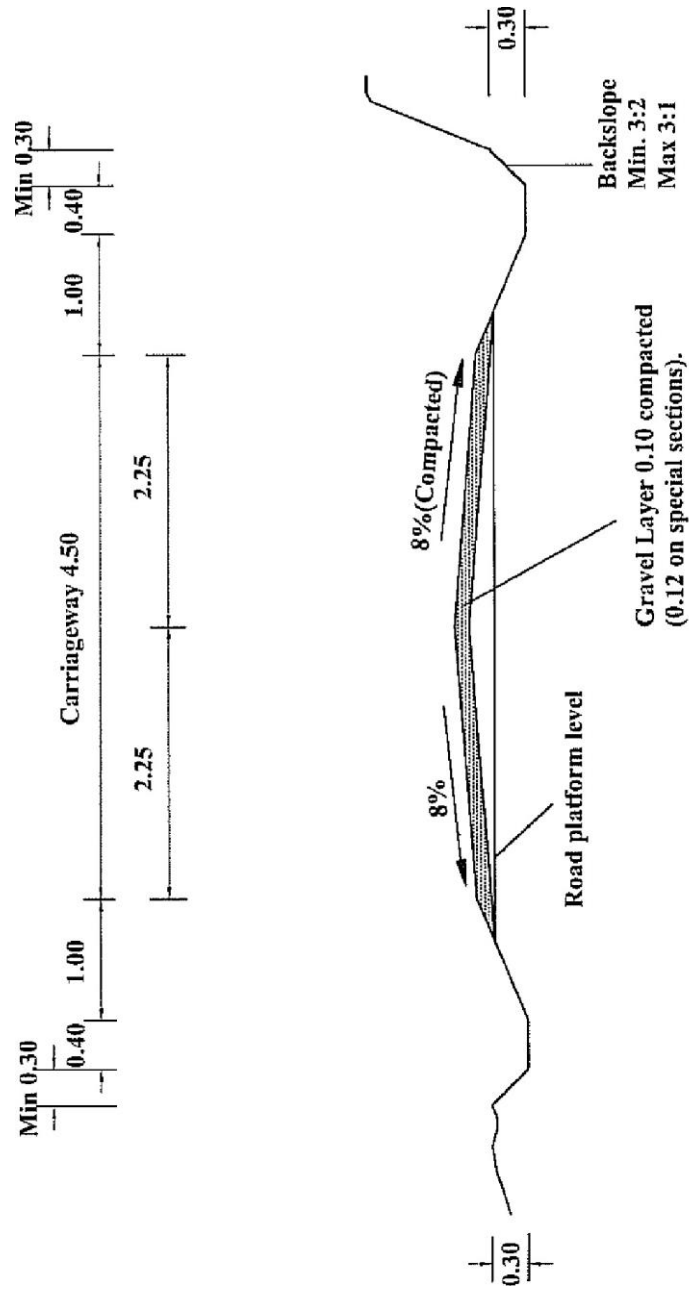


FIGURE C.I-CROSS SECTION A (MINOR STANDARD CROSS-SECTION)



- Notes:
1. All dimensions in metres
  2. Traffic levels of > 200vpd may justify a carriageway width of 6.0m
  3. Gravel thickness may be increased as directed by the Engineer

FIGURE C2- CROSS SECTION B (REDUCED CROSS-SECTION)



- Notes:
1. All dimensions in metres
  2. Gravel thickness may be increased as directed by the Engineer

FIGURE C3-CROSS- SECTION C (BLACK COTTON SOIL)

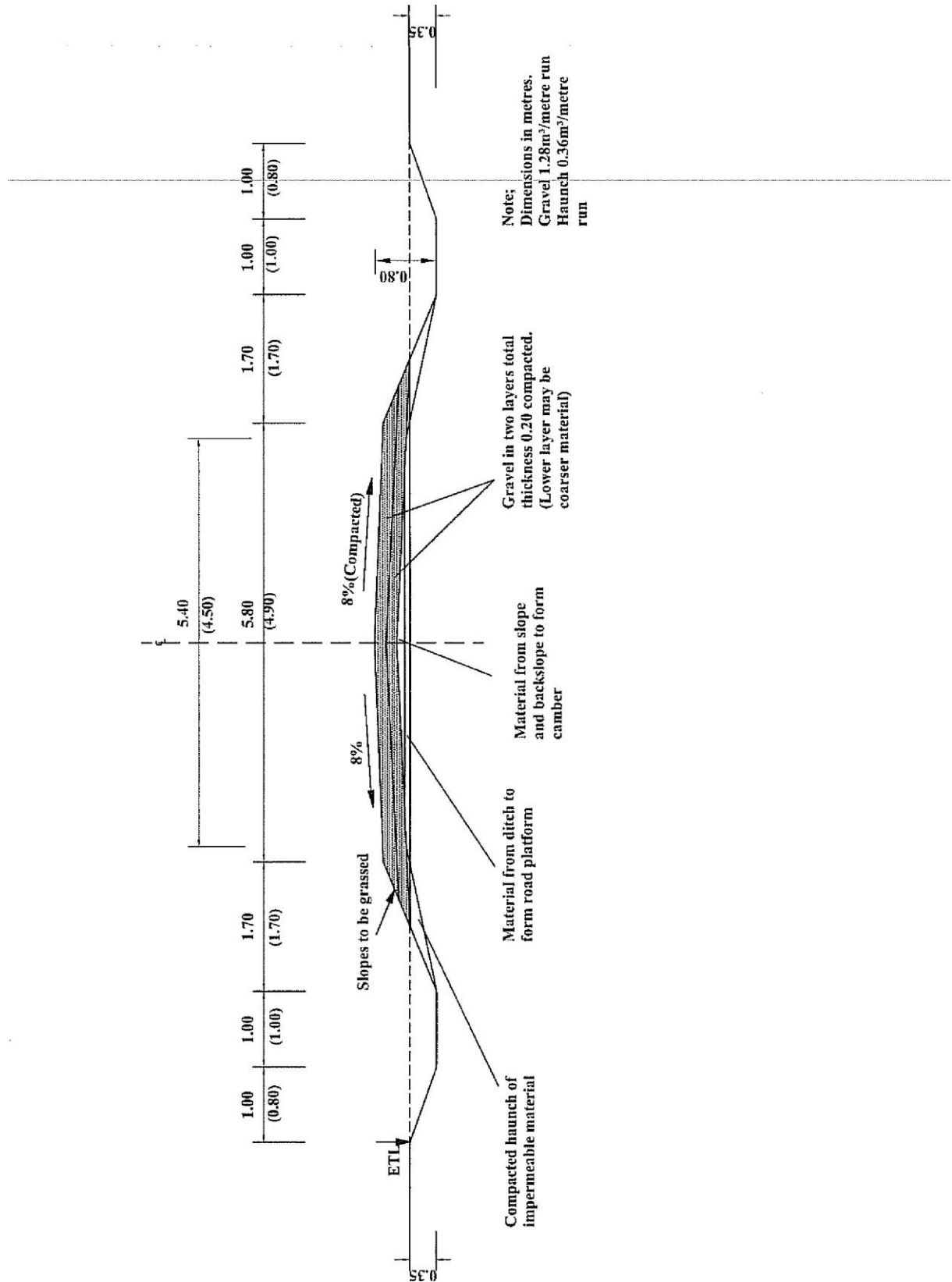


FIGURE C4-CROSS- SECTION D (SIDELONG GROUND)

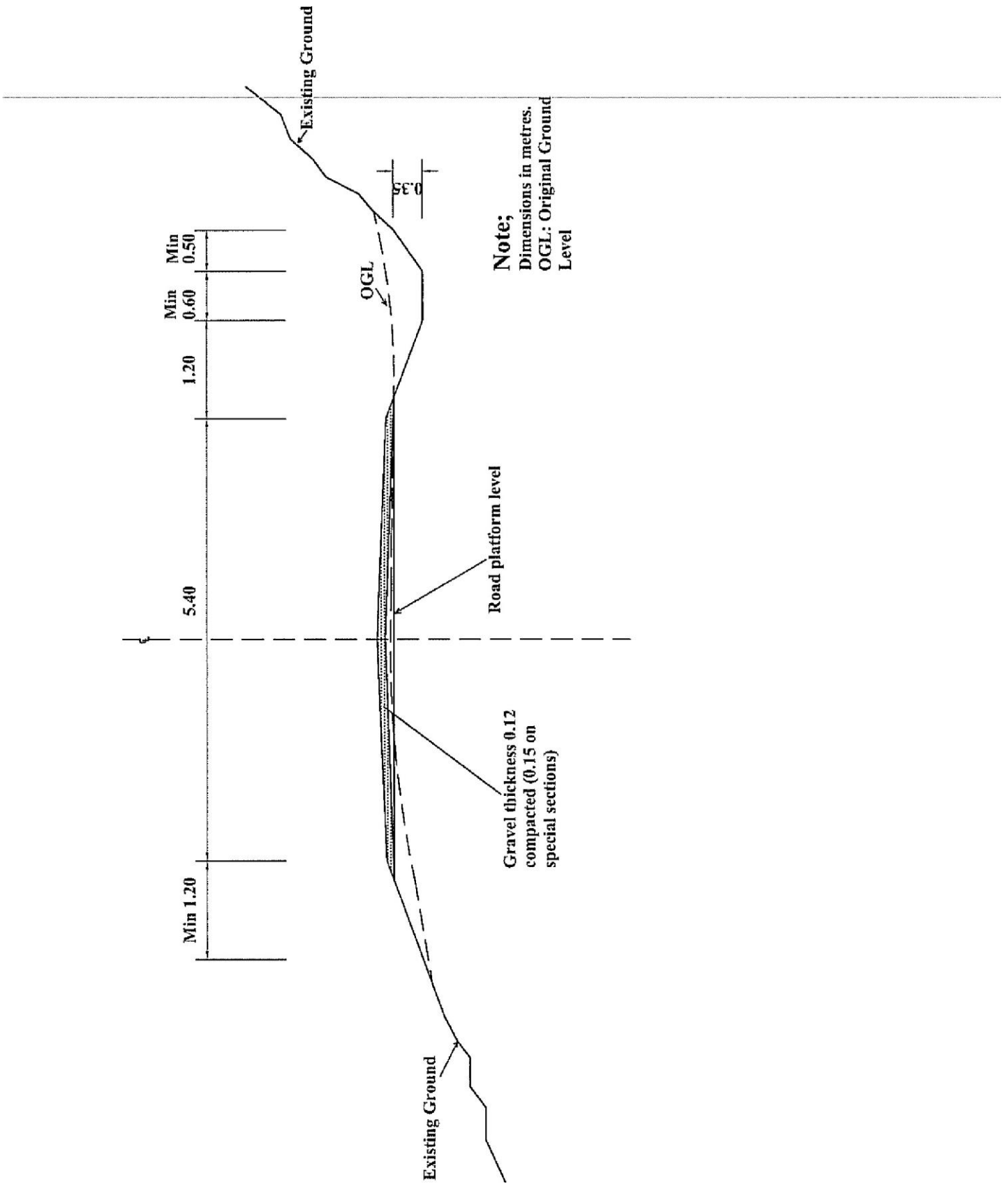


FIGURE C5- STANDARD CROSS- SECTION (SUPERELEVATION)

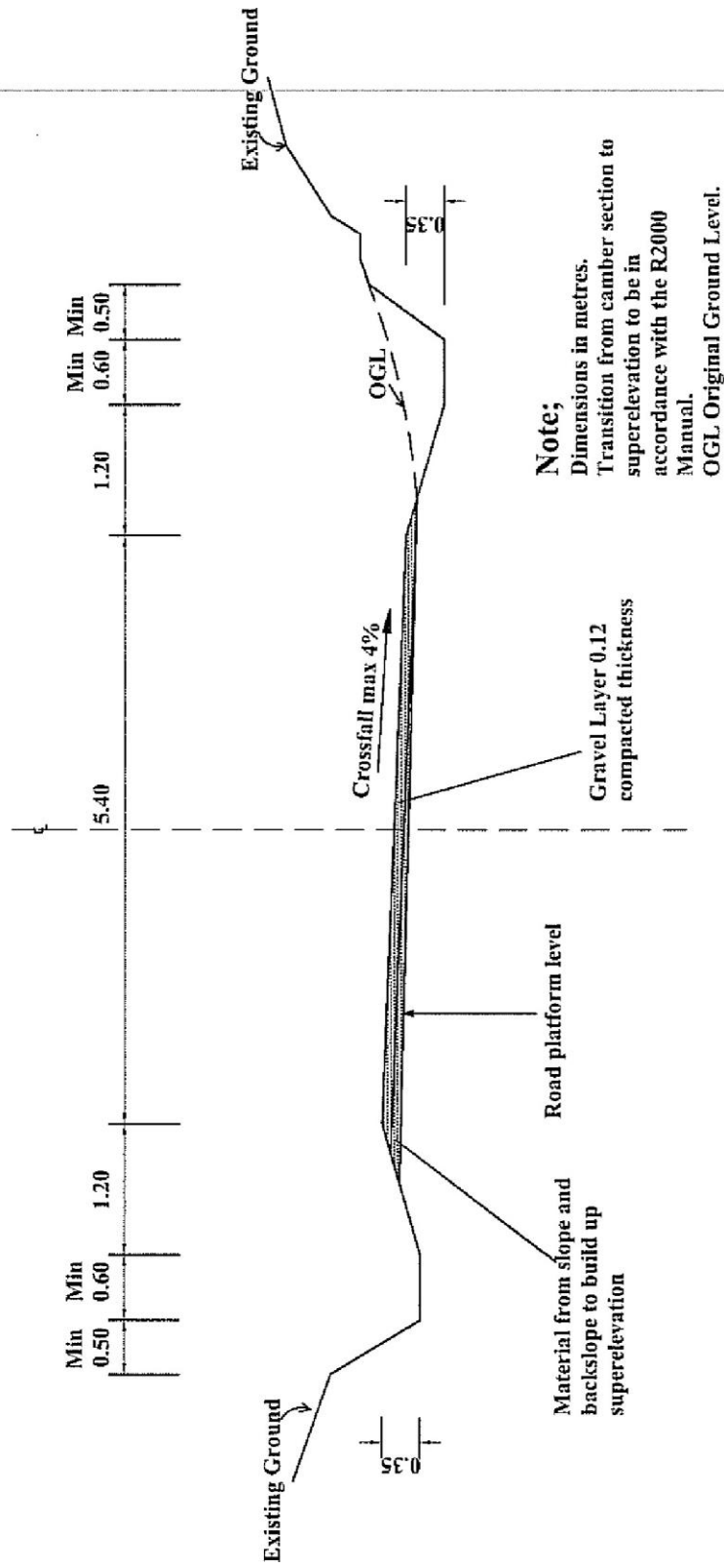
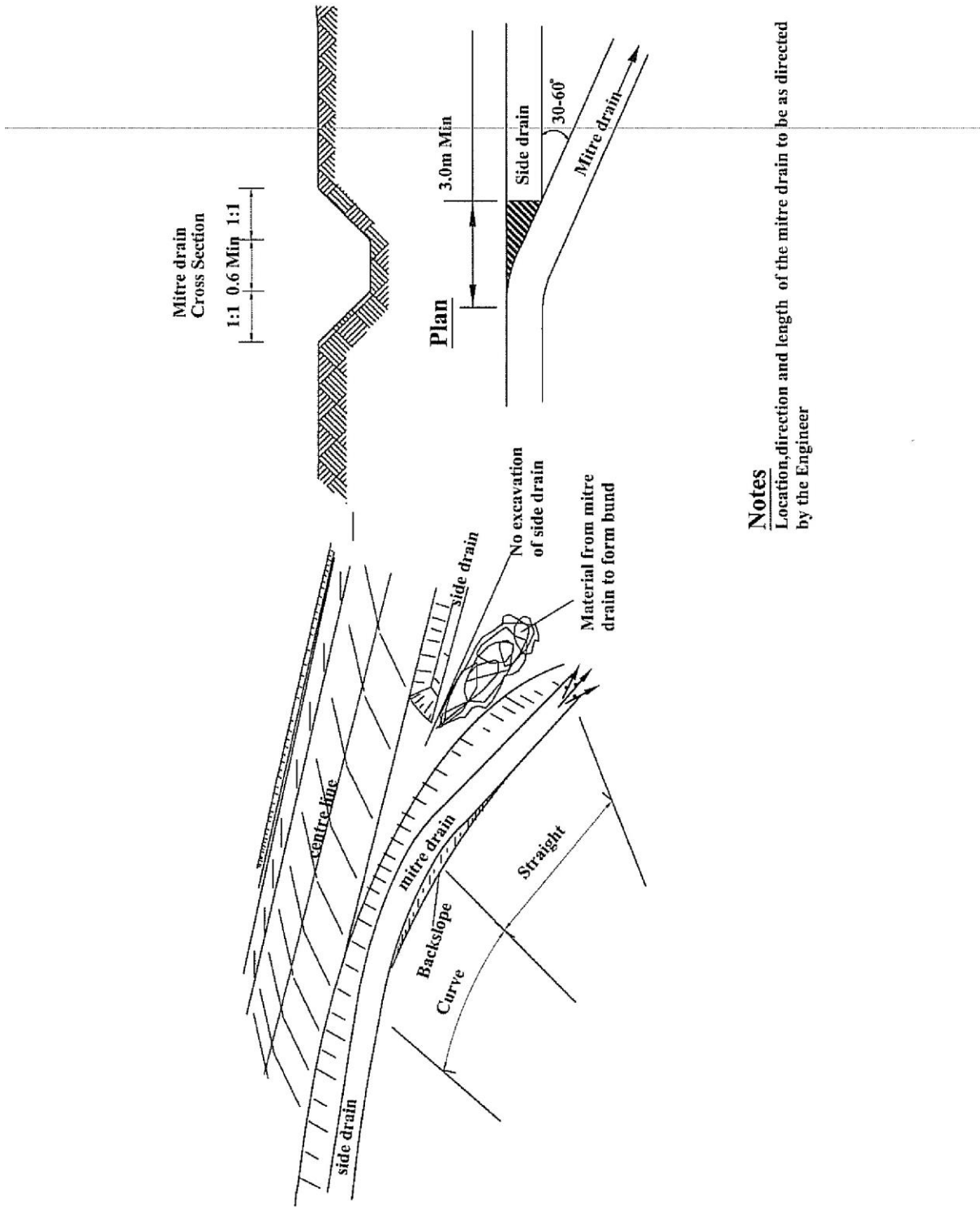


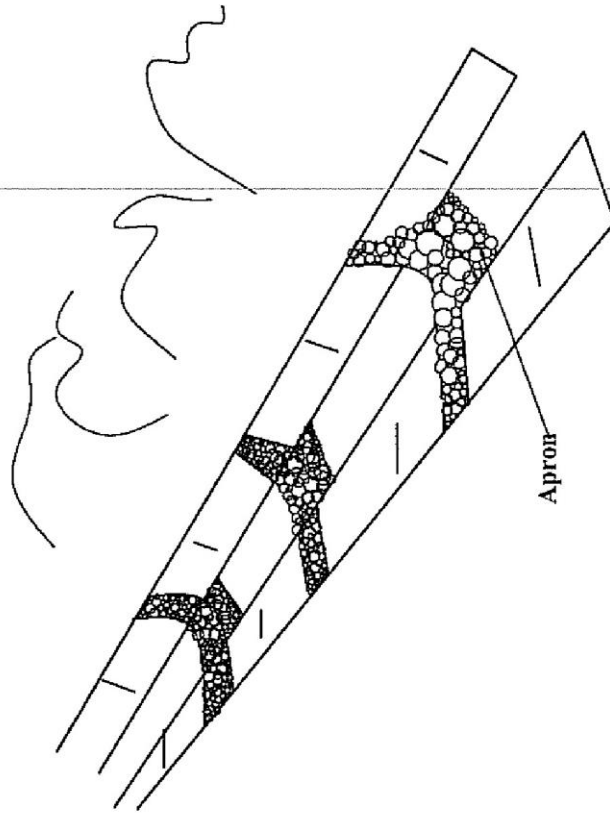
FIGURE C6 MITRE DRAINS



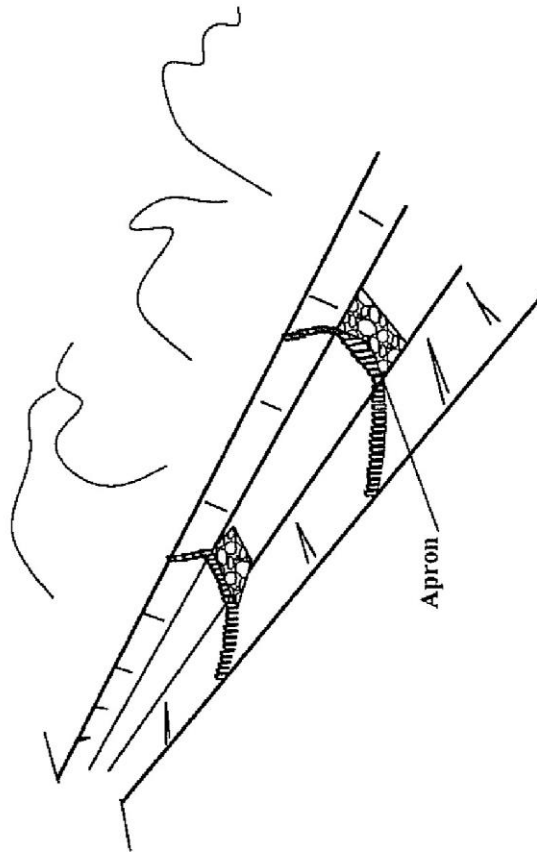
**Notes**  
 Location, direction and length of the mitre drain to be as directed by the Engineer

FIGURE C.7 SCOUR CHECKS

Scour checks made of stones

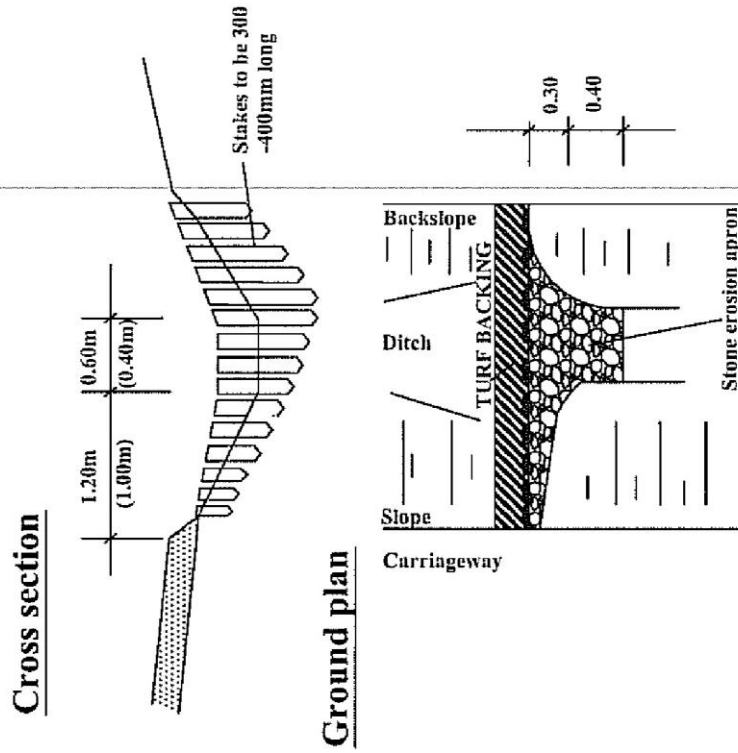


Scour checks made of wooden stakes

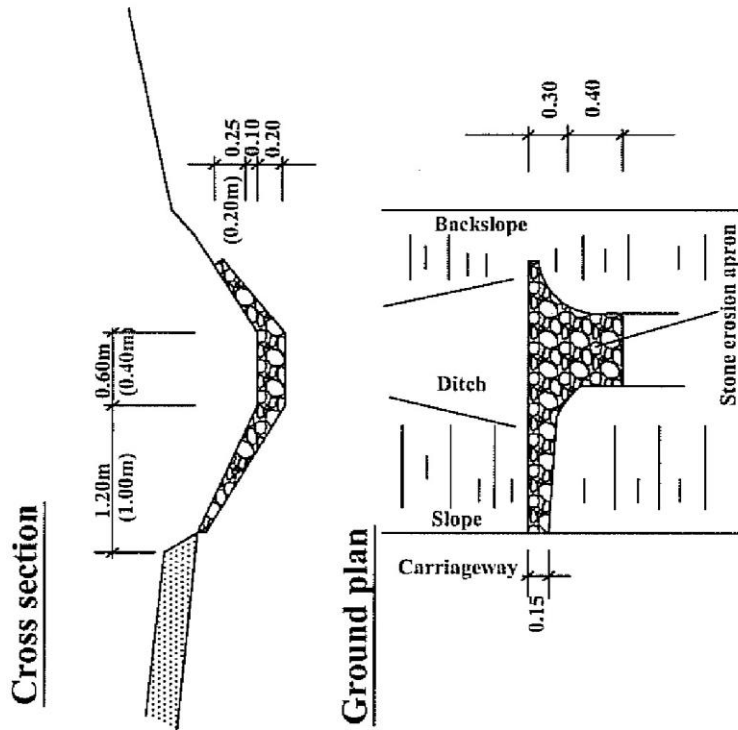


**FIGURE C8-DIMENSIONS OF SCOUR CHECKS FOR STANDARD DRAIN**

**Scour checks made of wooden stakes**



**Scour checks made of stones**

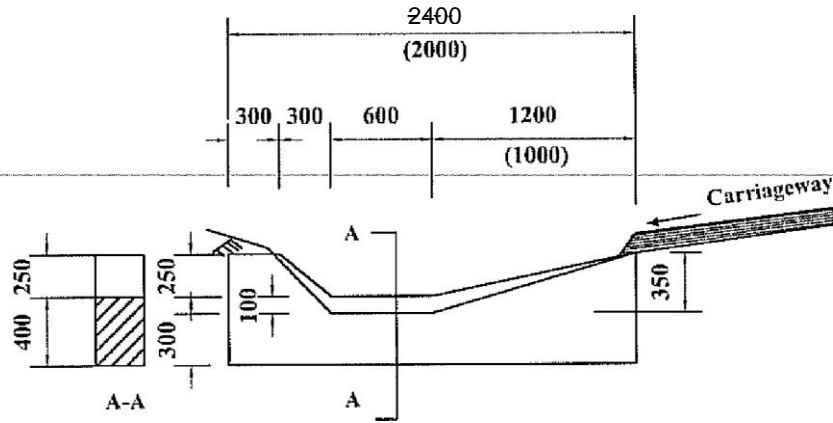


**NOTE**  
1. Dimensions in metres

**STONE WEIGHT: MIN 10KG**  
**STAKE DIAMETER: MIN. 0.10m**

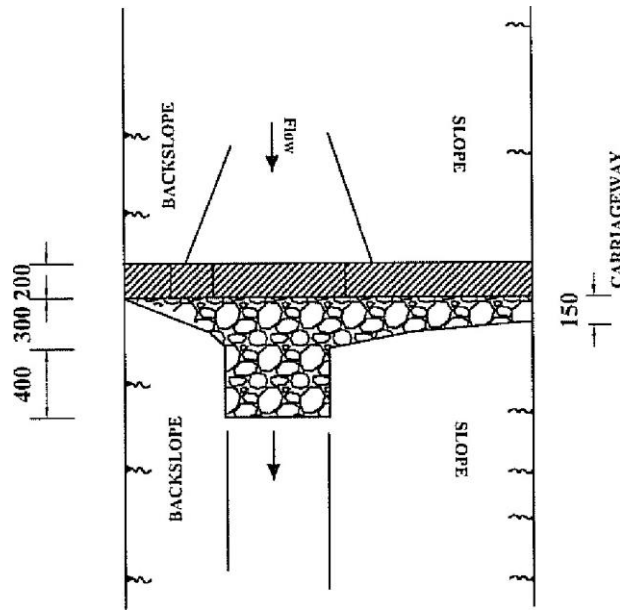


Figure C9a-Masonry Scour Checks



Note  
1. Dimensions in mm

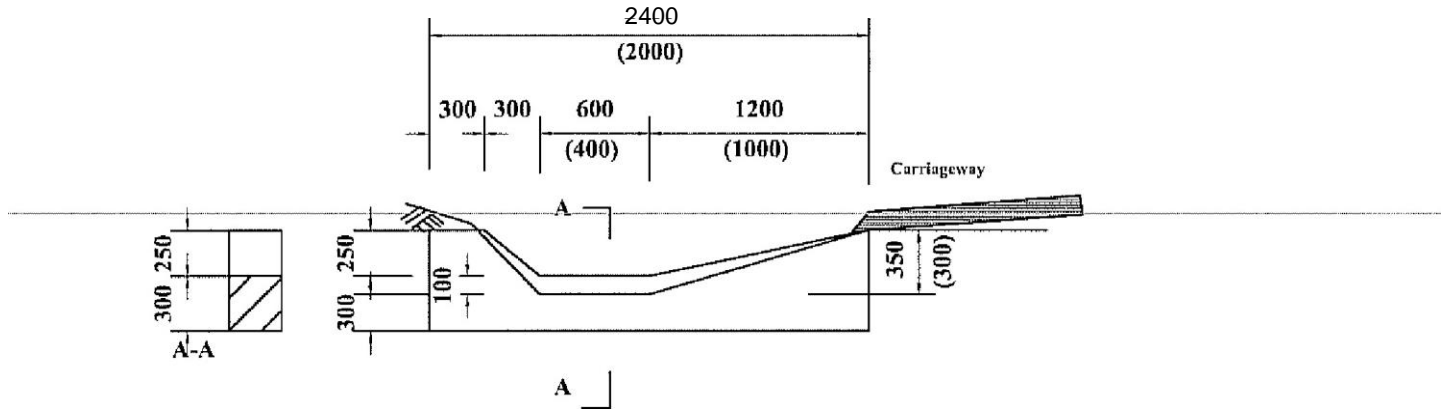
SECTION OF MASONRY SCOUR CHECK



PLAN OF DRAIN WITH SCOUR CHECK

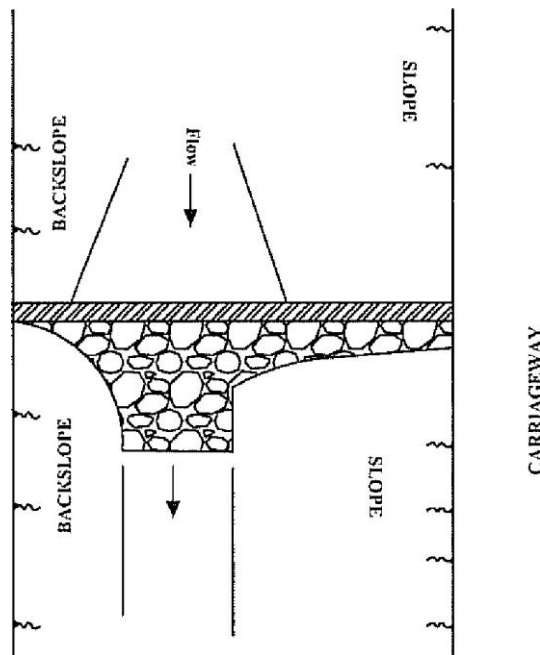
Cross-Section	Sizes In		Excav	Concret	Apt-nn stone pitel' (ng fileE3)
	Width	Depth			
	96				

FIGURE C9b- CONCRETE SCOUR CHECKS



SECTION OF CONCRETE SCOUR CHECK

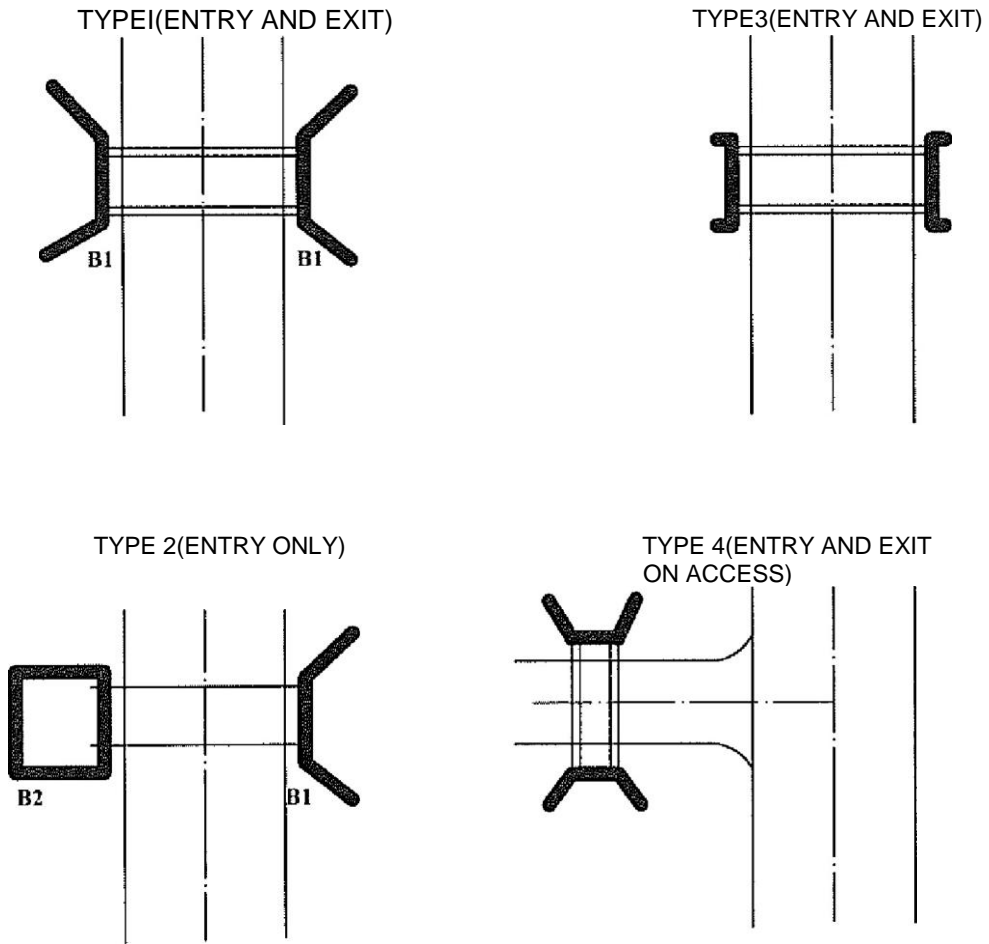
NOTL  
I. Dimensions in mm



PLAN OF DRAIN WITH SCOUR CHECK

Cross-section	Sizes in mm			Excav (m3)	concrete (m3)	Apron stone pitching
	Length	Width	Depth			
	2400	100	550			0.18
	2000	100	500	0.10	0.09	0.14

**FIGURE CIO- CULVERT ENTRY/EXIT STRUCTURE TYPES**

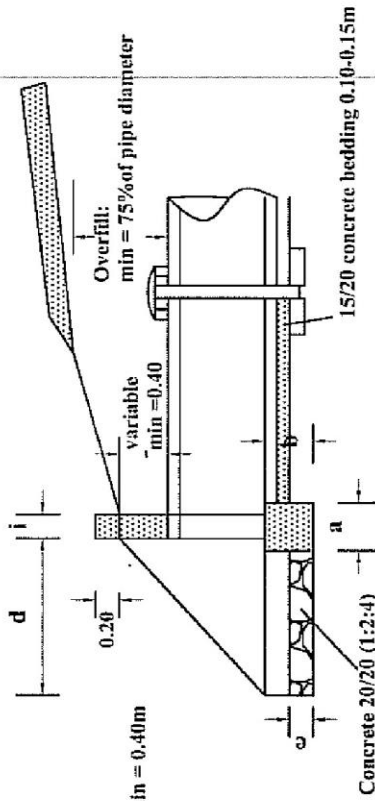


**NOTE**

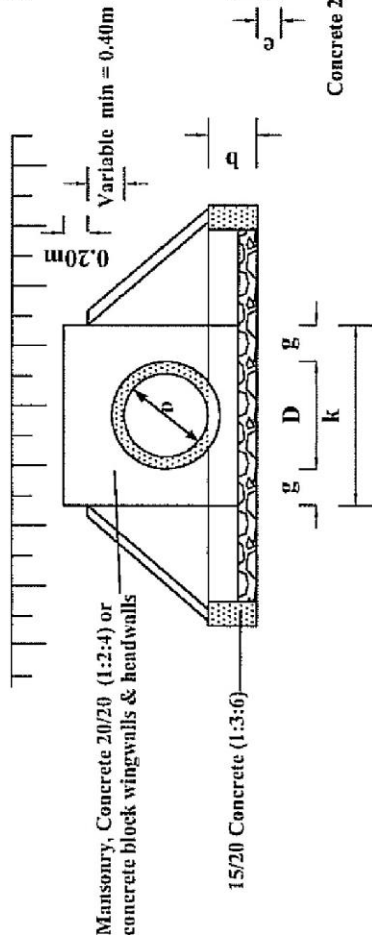
- I. The code numbers specify the shape and function and the code letter denotes the material;
- A =Concrete block
  - B =Stone masonry
  - C =Concrete

FIGURE CII,, HEADWALL TYPE 1 (HEAD AND WINGWALLS)

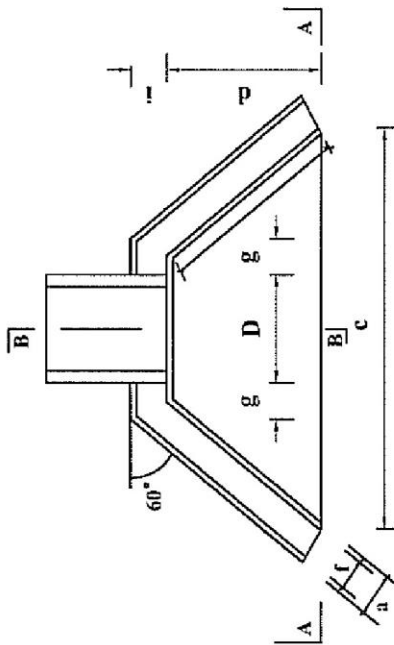
**SECTION B-B**



**SECTION A-A**



**PLAN**



CULVERT TYPES	
X-SECTION WIDTH m	No. of pipes
4.50	6
5.50	7
6.50	8

PIPE DIAMETER IN M	TYPE A and C CONCRETE BLOCKS MASONRY			TYPE B (STONE MASONRY)		
	450	600	900	450	600	900
<b>DIMENSION UNIT</b>						
a FOUNDATION	0.30	0.30	0.30	0.40	0.40	0.60
b FOUNDATION	0.30	0.30	0.40	0.30	0.30	0.40
c FOUNDATION	2.20	2.35	2.89	2.20	2.35	2.89
d APRON	1.00	1.00	1.20	1.00	1.00	1.20
e APRON	0.20	0.20	0.20	0.20	0.20	0.20
f WALL	0.20	0.20	0.20	0.40	0.40	0.40
g WALL	0.30	0.30	0.30	0.30	0.30	0.30
h WALL	1.15	1.15	1.39	1.15	1.15	1.39
i WALL	0.20	0.20	0.20	0.40	0.40	0.40
k APRON	1.05	1.20	1.50	1.05	1.20	1.50
<b>MATERIAL REQUIREMENT</b>						
FOUNDATION (concrete)	m <sup>3</sup>	0.30	0.32	0.51	0.40	1.03
HEAD/WINGWALLS (Concrete/Masonry)	m <sup>3</sup>	0.42	0.49	0.70	0.84	1.40
APRON (concrete)	m <sup>3</sup>	0.33	0.36	0.53	0.33	0.53

FIGURE C12.HEADWALL TYPE 2(DROP INLET)

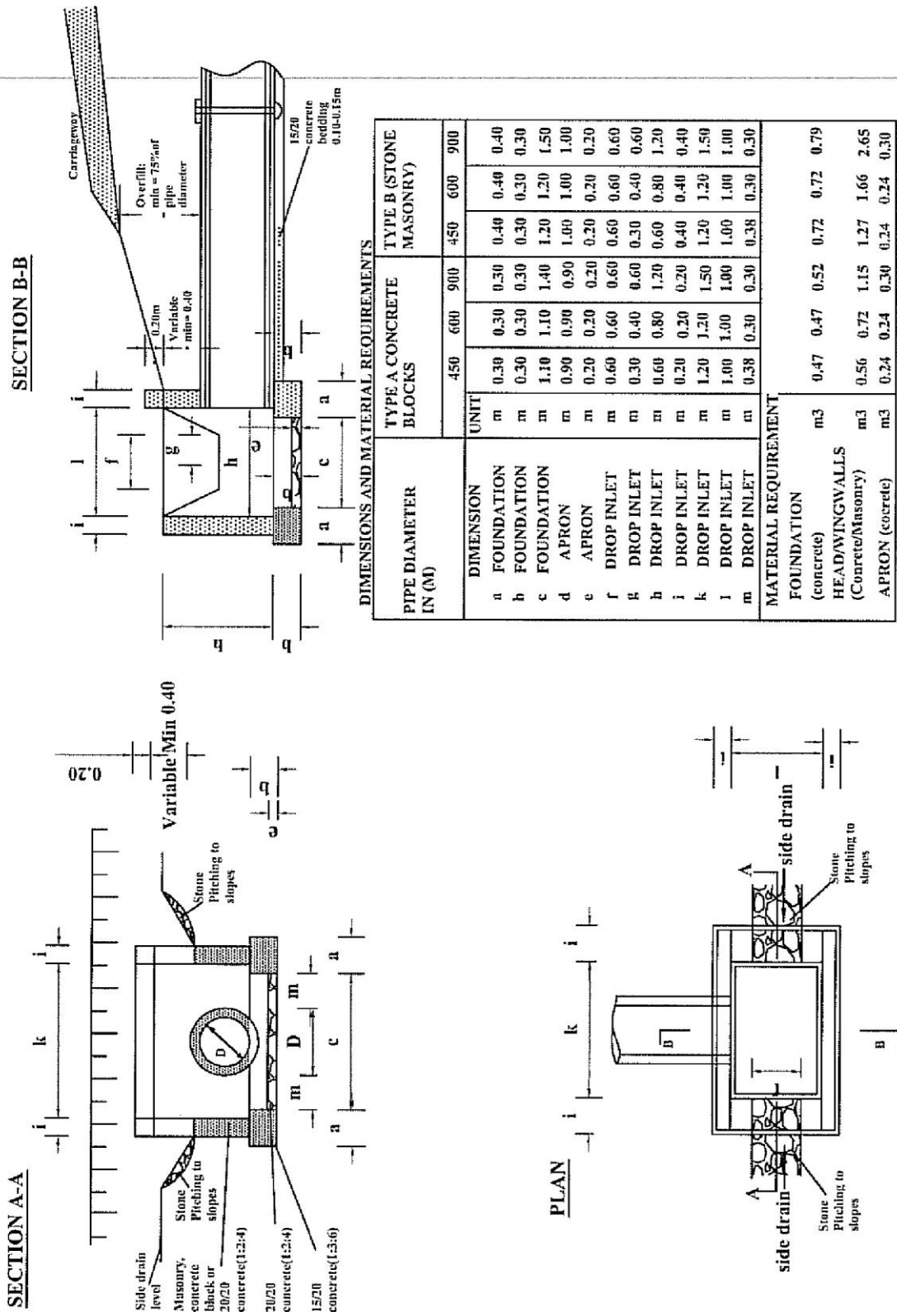


FIGURE C.13-HEADWALL TYPE 3A (CONCRETE/ BLOCK HEADWALLS)

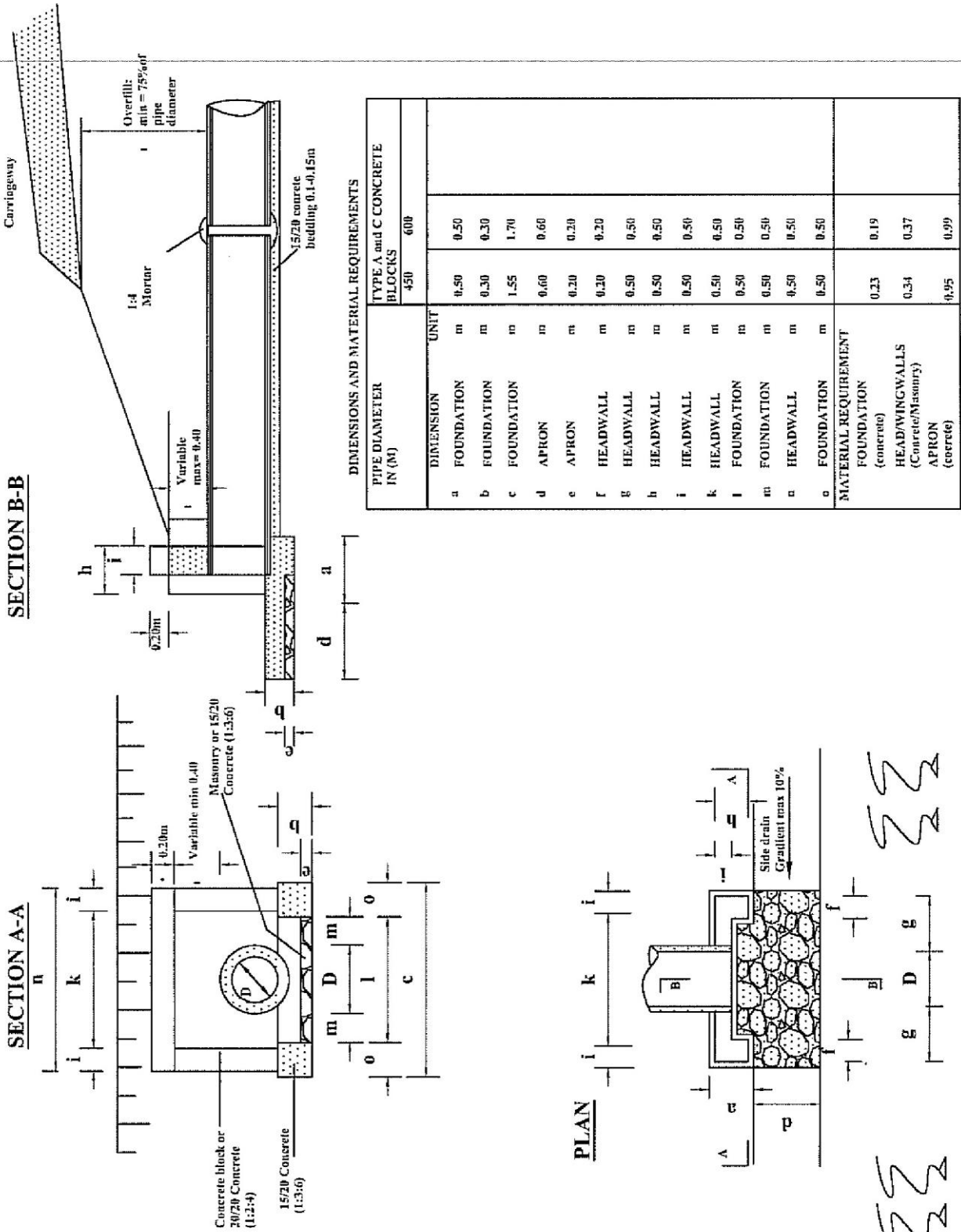


FIGURE C14-HEADWALL TYPE 3B (STONE MASONRY HEADWALLS)

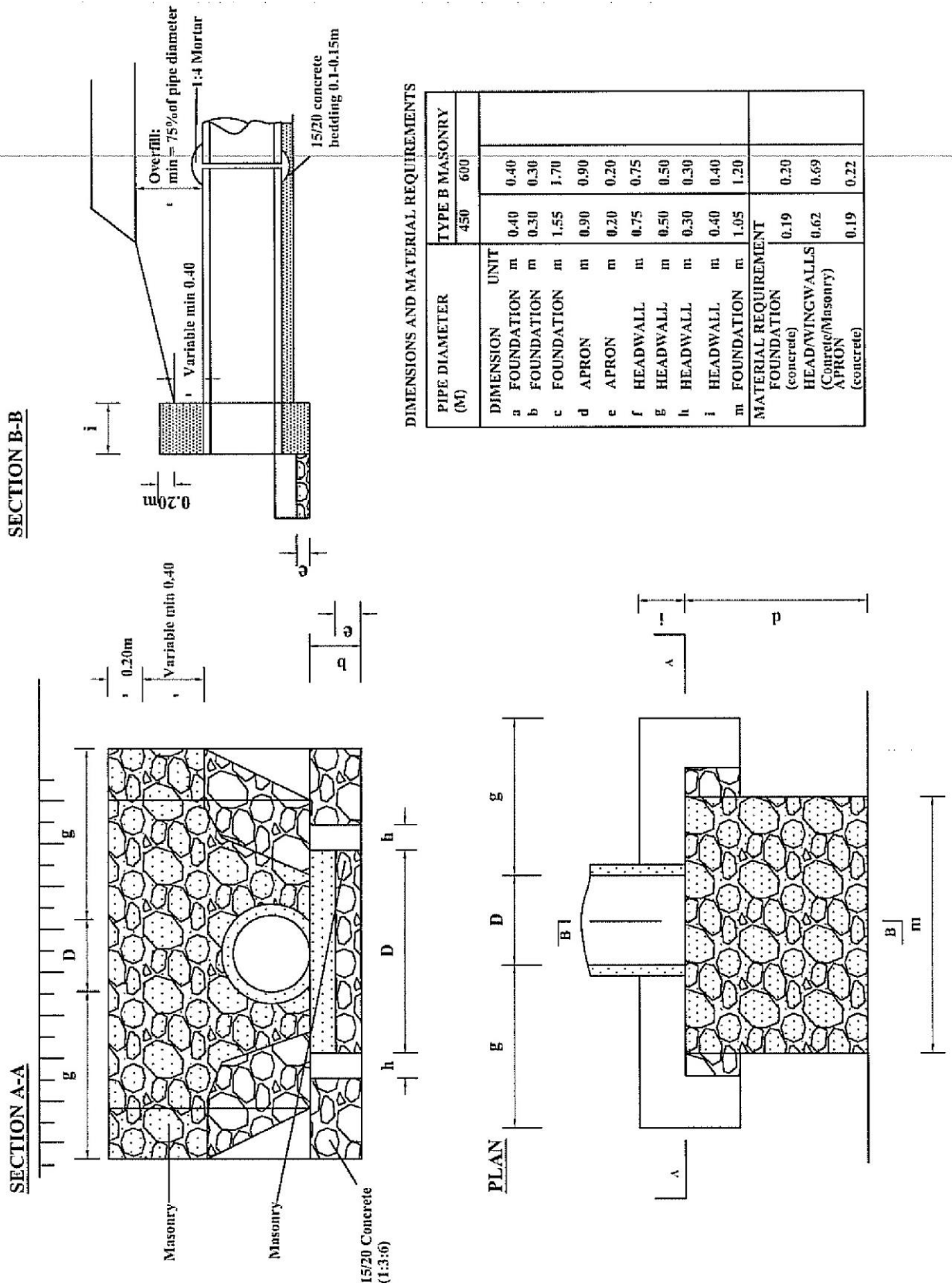
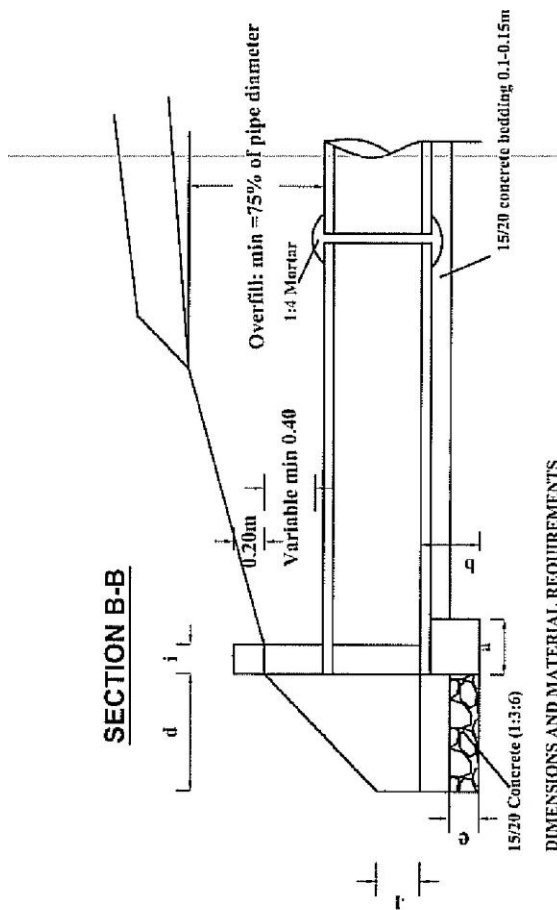
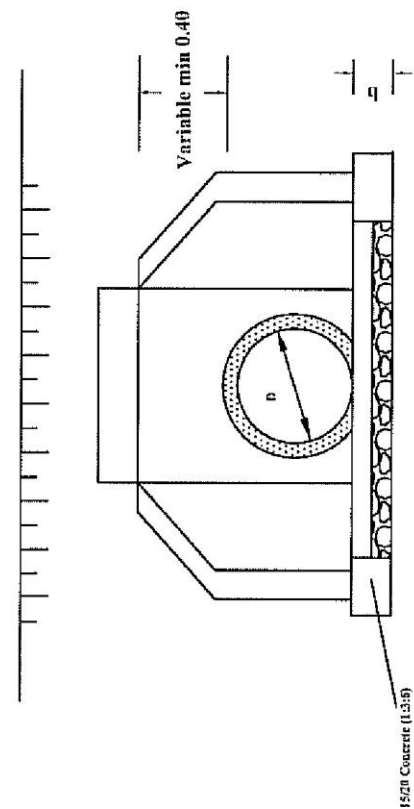


FIGURE C15-HEADWALL TYPE FOR ACCESS CULVERTS)



SECTION B-B

SECTION A-A



**DIMENSIONS AND MATERIAL REQUIREMENTS**

PIPE DIAMETER IN (M)	DIMENSION	UNIT	TYPE A (CONCRETE BLOCKS)			TYPE B (STONE MASONRY)		
			450	600	900	450	600	900
a	FOUNDATION	m	0.30	0.30		0.40	0.40	
b	FOUNDATION	m	0.30	0.30		0.30	0.30	
c	APRON	m	1.34	1.49		1.34	1.49	
d	APRON	m	0.60	0.60		0.60	0.60	
e	APRON	m	0.20	0.20		0.20	0.20	
f	WINGWALLS	m	0.20	0.20		0.40	0.40	
g	WINGWALLS	m	0.10	0.10		0.10	0.10	
h	HEADWALLS	m	0.69	0.69		0.69	0.69	
i	HEADWALLS	m	0.20	0.20		0.40	0.40	
k	HEADWALLS	m	0.65	0.80		0.65	0.80	
l	HEADWALLS	m	0.40	0.40		0.40	0.40	
<b>MATERIAL REQUIREMENT</b>								
FOUNDATION (concrete 1:3:6)			0.18	0.20		0.24	0.26	
HEAD/WINGWALLS (Concrete/Masonry)			0.25	0.32		0.53	0.61	
APRON (concrete)			0.12	0.14		0.12	0.14	

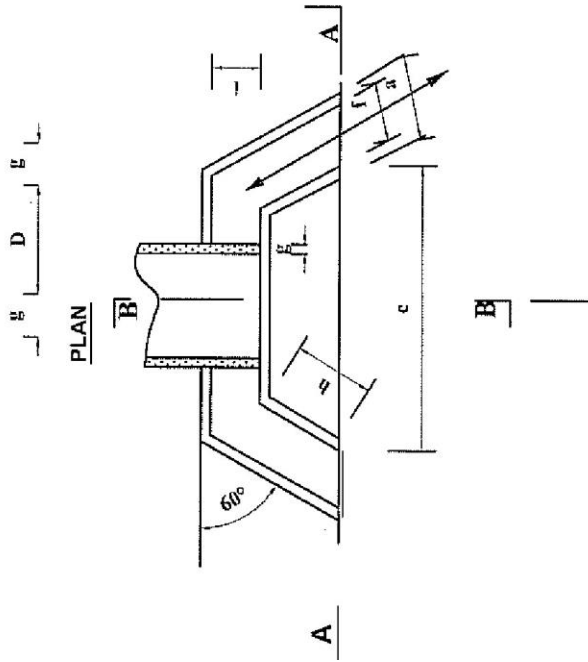
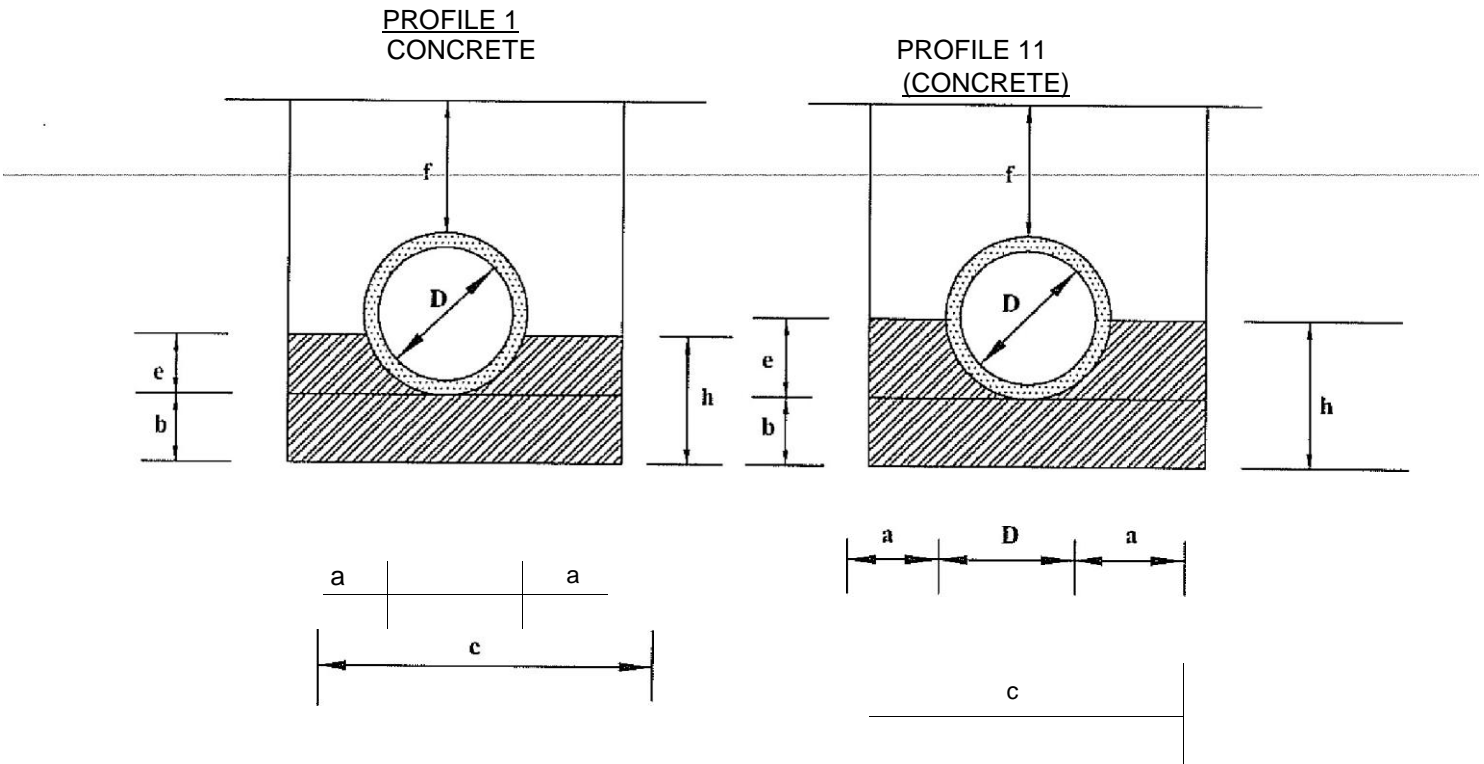




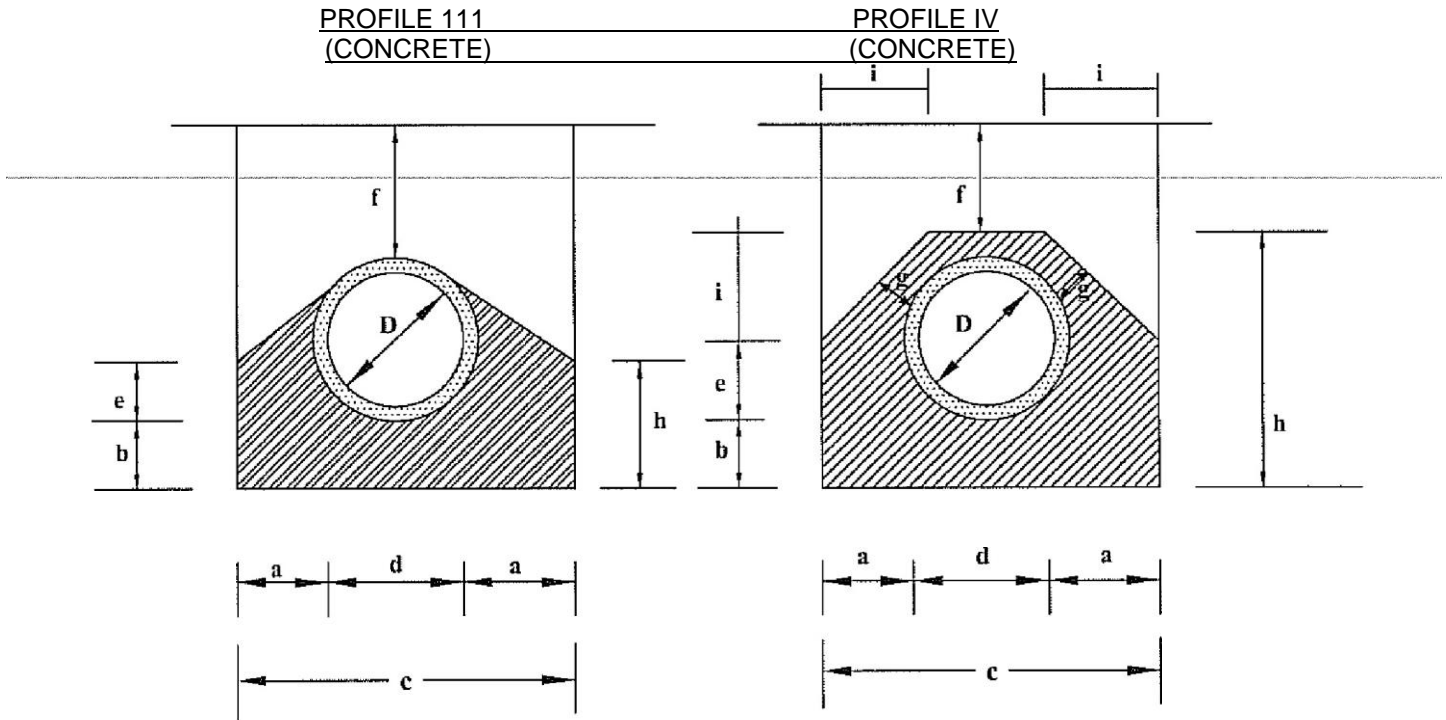
FIGURE C16-BEDDING AND HAUNCH PROFILE TYPES I & II



Diameter (D)	900		
Concrete Class	15/20		
Volume in (m <sup>3</sup> /m)	0.24	0.24	0.24
Application	-Fair subgrade condition -Overfill > 75% of the pipe diameter Seasonal water now only		
Remarks	Material for back/overfill shall be approved by the Engineer		

Volume in (m <sup>3</sup> /m)	0.20	0.37	0.56
Application	-Fair to poor subgrade condition -Overfill > 75% of the pipe diameter -Seasonal water flow only		
Remarks	Material for back/overfill shall be approved by the Engineer		

FIGURE C17-BEDDING AND SURROUND PROFILE TYPES III & IV

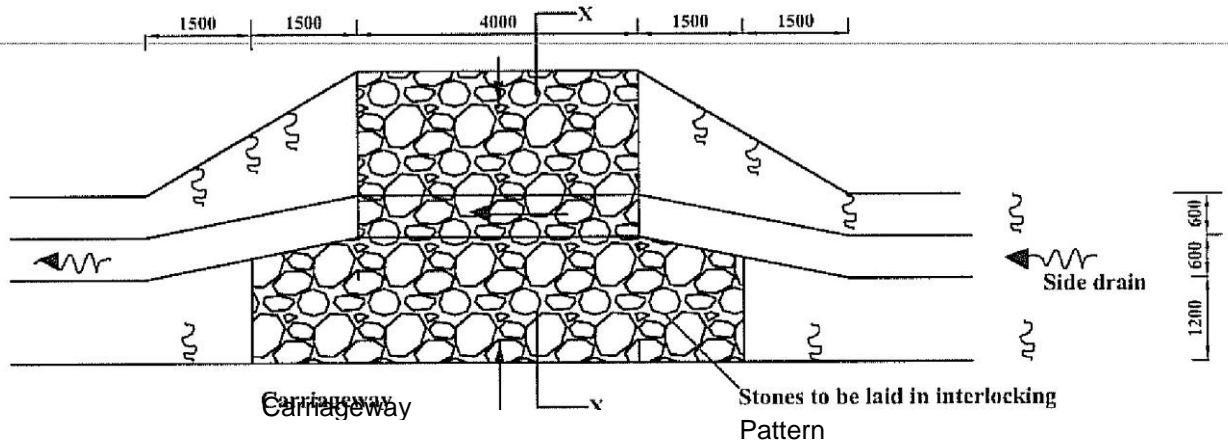


Diameter (D)			
<b>Concrete</b>	<b>Volume in (m3/m)</b>		
Class 15/20			
Application	-Fair subgrade condition -Overfill > 75% of the pipe diameter -Seasonal water now only		
Remarks	Material for back/overfill shall approved by the Engineer		

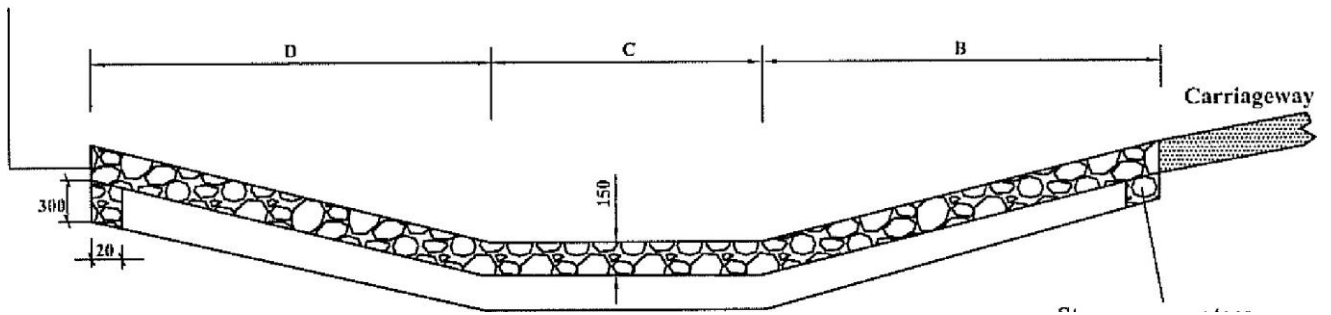
Diameter (D)			
	<b>Volume in (m3/m)</b>		
	-Fair to poor subgrade condition -Overfill > 75% of the pipe diameter -Seasonal water flow only		
	Material for back/overfill shall approved by the Engineer		

### FIGURE C18-ACCESS DRIFT

#### PLAN



150mm Grouted Stone Pitching  
(Cement  
Cement mortar 1:4)



mortar 1

Stone masonry toes on four sides of structure

### SECTION X-X (200\*300mm)

QUANTITIES TABLE								
Cross section	DIMENSIONS					Excavation(m3)	Stone masonry (m3)	150mm Grouted stone pitching(m3)
	4000	1800	600	1800	4200	7.5	1.30	
	6000	1800		1800	4200	10.00		
	4000	1400	400	1800	3600	7.00		
	6000	1400	400	180	3600	9.00	t.50	25.50

C-18

FIGURE C19-LEVEL DRIFT

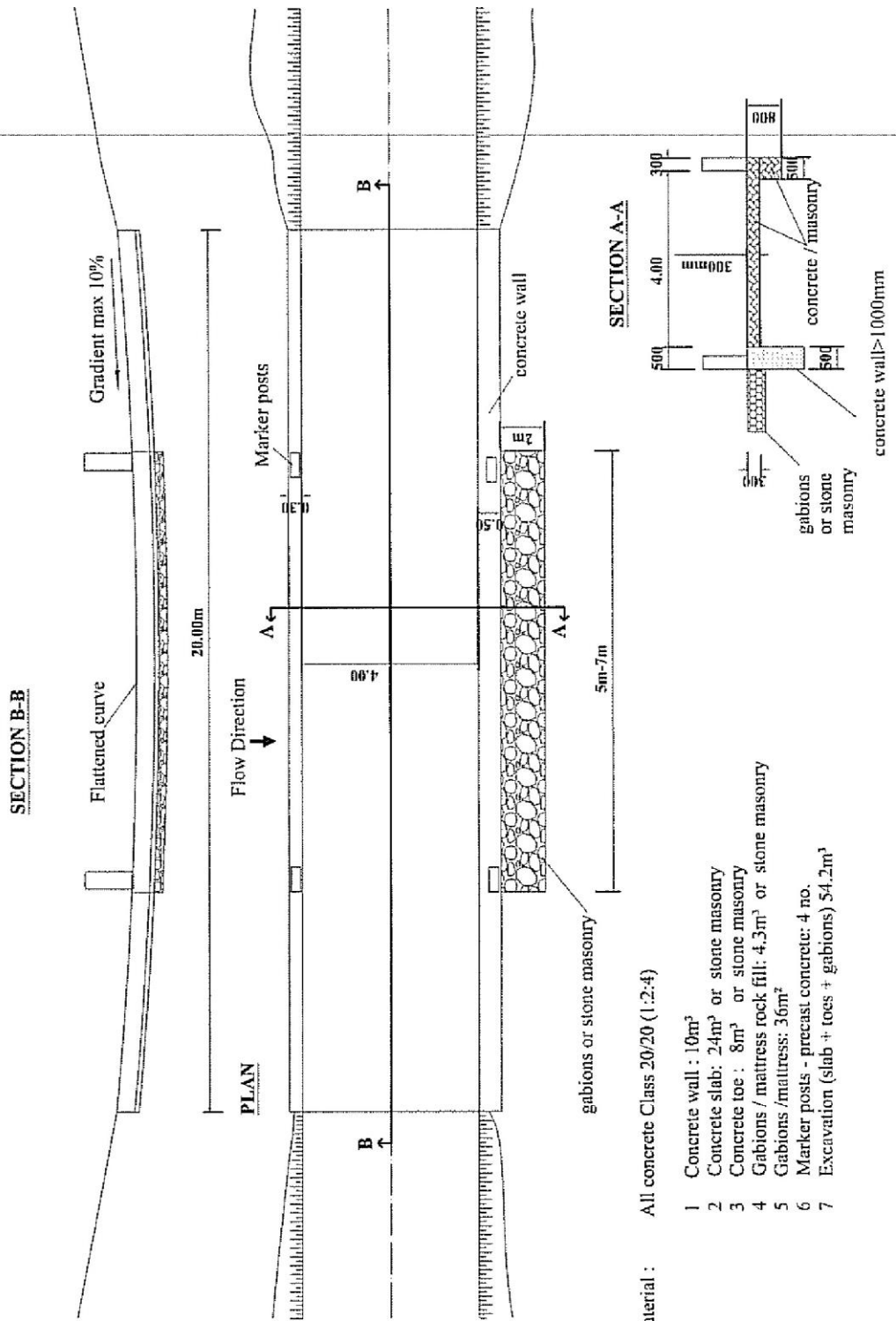
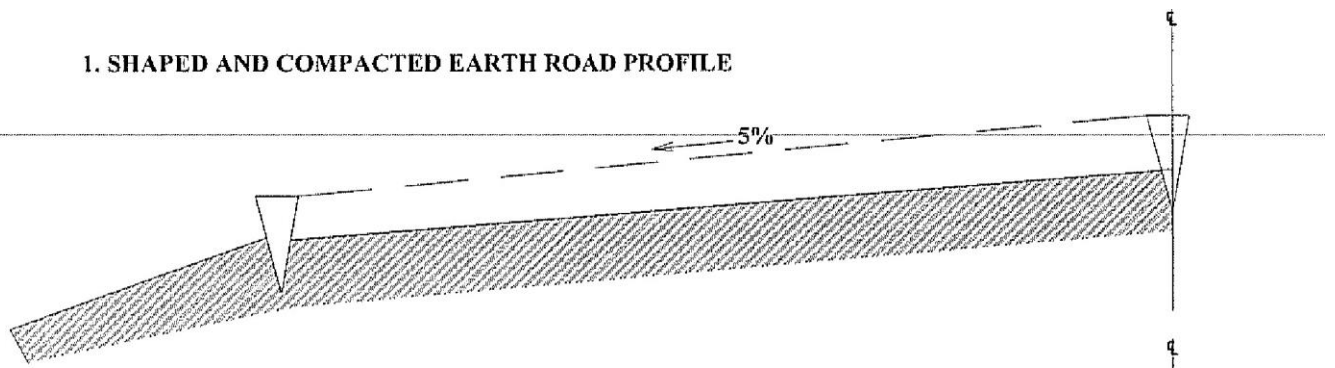


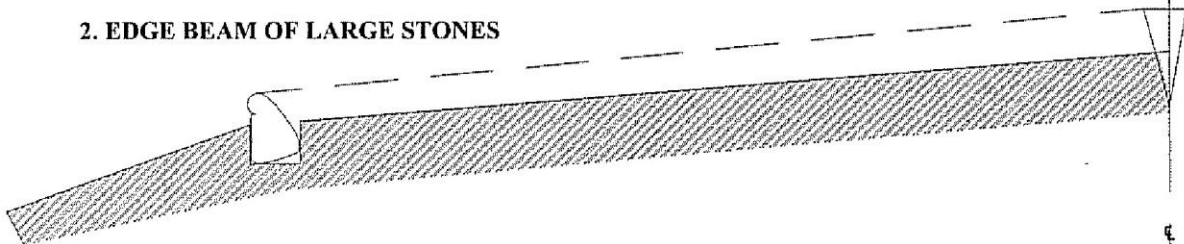


FIGURE C21-HAND PACKED STONE PAVEMENT

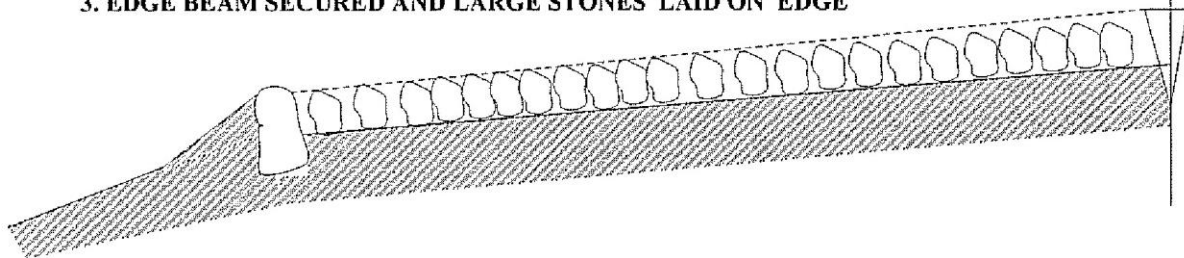
1. SHAPED AND COMPACTED EARTH ROAD PROFILE



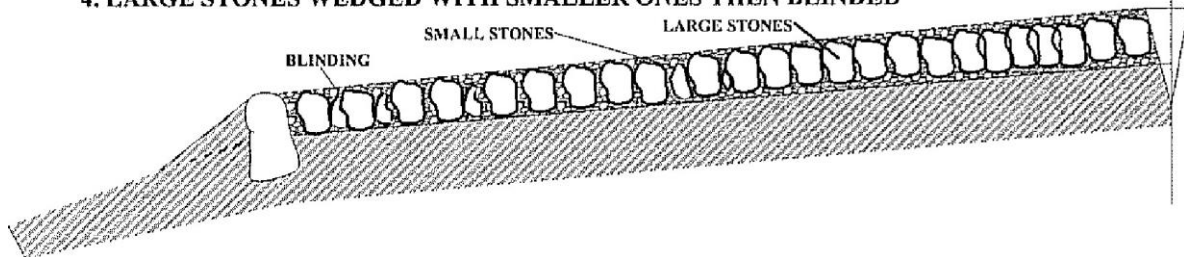
2. EDGE BEAM OF LARGE STONES



3. EDGE BEAM SECURED AND LARGE STONES LAID ON EDGE

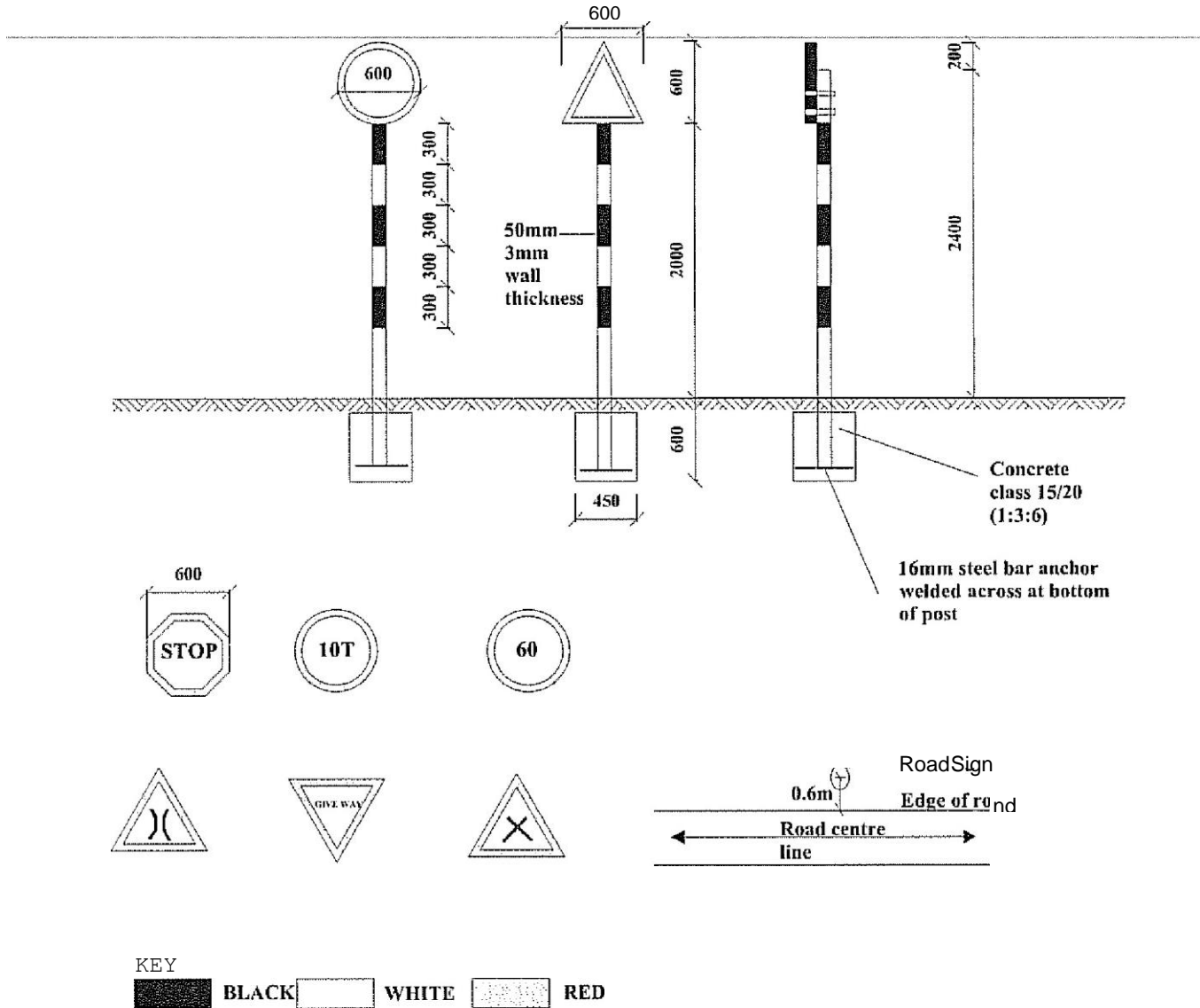


4. LARGE STONES WEDGED WITH SMALLER ONES THEN BLINDED



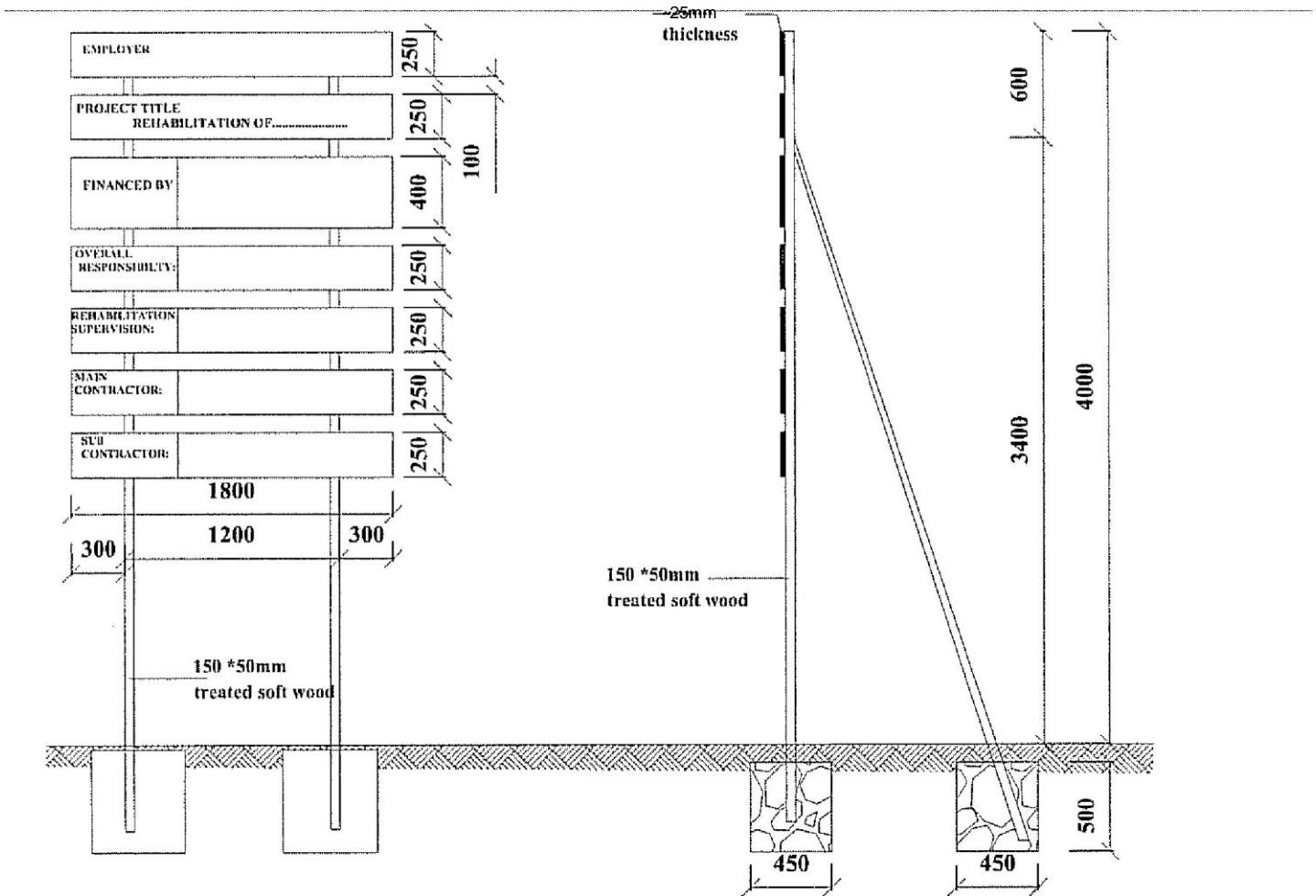
C-21

FIGURE C22-TRAFFIC SIGNS



1. The type of sign required and their location shall be as shown on the Road Plan or as directed by 1112 Engineer.
2. Sign plate to be 2mm thick mild steel plate
3. Sign post to be 50mm fixing clamps/brackets.
4. Sign plate to be fixed to steel tube by \$ Nos MIO bolts and 50mm fixing clamps/brackets.
5. Sign paints shall be reflective.
6. The sign plate and post shall be treated by applying two coats of lead red oxide paint before applying n priming and two finish coats of approved paints. Paints used Shull have a hard, durable and glossy finish.

# C-22FIGURE C23-PUBLICITY SIGNBOARD



WHITE

BLACK

## NOTES

1. The wording of the project sign board and the location to be as directed by the Engineer.
2. Materials to be used for fabrication or signboard shall be pressure impregnated treated softwood timber
3. Wording board posts to be attached to the posts with galvanised nails
4. Project board posts and struts to be embedded in concrete class 20/20(1:2:4)



## **PREAMBLE TO BILLS OF QUANTITIES**

1. The Bills of Quantities form part of the Contract Documents and are to be read in conjunction with the Instructions to Tenderers and these Documents.
2. The prices and rates to be inserted in the Bills of Quantities are to be the full, inclusive value of the work described under the several items including all costs and expenses which may be required in and for the execution of the work described and for the Contractor's overheads and profits. The rates shall be VAT exclusive but include all other taxes, levies and fees applicable. The rates shall be based on the Works being carried out in accordance with the R2000 Strategy of using optimum labour resources.
3. Each item in the Bills of Quantities contains only a brief description of the required work. Fuller details and descriptions of the work to be done, the materials to be used, the standards of workmanship, methods of measurement and payment are to be found in the various sections of the Specifications and on the Drawings.
4. The Quantities set out in the Bills of Quantities are estimated and represent substantially the work to be carried out. There is no guarantee that the Contractor will be required to carry out all the quantity of work indicated under any one particular item or group of items in the Bills of Quantities. The basis of payment shall be the Contractor's rates and the quantities of measured work done in fulfilment of the obligations under the Contract.
5. Work shall be carried out under Day works items only at the direction, and with the approval, of the Engineer. The Contractor shall enter rates in the Day works Schedule of Rates, which shall reflect the realistic costs, including overheads and profit, of each item. If, in the opinion of the Engineer, a rate is unreasonably high or low, the Contractor may be required to amend the rate to the satisfaction of the Engineer.

## **BILLS OF QUANTITIES**

Section Name  
 C42 RASHID-  
 CHEBUKWABI-  
 (Daraja Mungu  
 Pri.School-  
 R.Kibisi)

Road  
 Code E316J1

**Package:**  
 KeRRA/011/BGM/KML/10%RMFL/39/20/21-083

Contractor

<b>Bill of Quantities</b>					Page: 1
Bill No.1	General: Office administration and overheads/Preliminaries				Project:
Item No.	Description	Units	Quantity	Unit Bid Rate(Ksh)	Amount KSh
01-60-005	Publicity Sign Boards	no	2		
<b>Total Carried Forward to Summary:</b>					





Code

RASHID  
CHEBUKWABI(Daraja  
Mungu Pri.School-  
R.Kibisi)

Package:  
KeRRA/011/BGM/KML/10%RMFL/39/20/21-083  
Contractor

<b>Bill of Quantities</b>					Page: 4
Bill No.10	GRADING AND GRAVELLING WORKS				Project:
Item No.	Description	Units	Quantity	Unit Bid Rate(Ksh)	Amount KSh
10-50-001	Heavy grading without watering or compaction instructed by the Engineer	M <sup>2</sup>	10000		
10-60-001	Provide gravel wearing course- excavation, free haul, spread, water and compact gravel to specifications	M <sup>3</sup>	1040		
<b>Total Carried Forward to Summary:</b>					

